



canfield
connector

Sensors

Electrical

Connectors

Timers

Accessories

Buyer's Guide



www.canfieldconnector.com

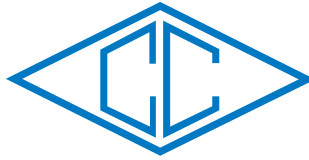

canfield connector

Quality is our goal.

Canfield Connector is a manufacturer of interconnection devices, electronic timers, modules and specialty electronic devices targeted at the fluid power industry. Our *Complete Quality Control Program* (CQCP) protects our customers by assuring them of 100% test and inspection prior to shipment of all items produced at Canfield Connector. Most items are tested during the manufacturing process and again during final inspection, making our products double or triple tested for function prior to shipment. Our Quality Policy at Canfield Industries is: Total Customer Satisfaction Through Unmatched Quality, Products, Service, and Integrity. Our Quality Objectives are Customer Satisfaction, On-Time Delivery, Sales and Profit Growth, High Quality Products, and Superior Supplier Performance. Canfield Connector operations have been certified to the ISO 9001 With Design International Quality System Standard.

1 year warranty

All products manufactured by Canfield Connector are warranted by Canfield Connector to be free of defects in material and workmanship for a period of one year from the purchase date. Canfield Connector's obligation under this warranty is limited to repair or replacement of the defective product or refund of the purchase price paid solely at the discretion of Canfield Connector and provided such defective product is returned to Canfield Connector freight prepaid and upon examination by Canfield Connector such product is found defective. This warranty shall be void in the event that the product has been subject to misuse, misapplication, improper maintenance, or tampering. This warranty is expressed in lieu of all other warranties, expressed or implied from Canfield Connector representatives or employees.

Technical assistance

Our trained technical staff is available at (330) 758-8299 or 1-800-554-5071 to help you with your questions concerning Canfield products. All questions are welcome. We are constantly developing new product lines and custom products for different applications. Ask our sales representative for more details.



Ordering made easy

Our order desk is open 8:00 AM to 5:00 PM EST Monday through Friday. Call us at (330) 758-8299 or 1-800-554-5071 to place your order or fax us at (330) 758-8912.

Designs and published data

All designs and specifications are subject to change without notice. Such changes are not to be considered retroactive, and seller assumes no responsibility for revision of models already in the field. All data is sufficiently accurate for general use, but seller assumes no responsibility for errors or omissions. Certified prints are available on request, at a reasonable charge.



MADE IN USA

Canfield Industries, Inc.



**ISO 9001:2015
with design
Cert # 05.096.1**

****DISCLAIMER****

Product changes including specifications, features, designs, and availability are subject to change anytime without notice. For critical dimensions or specifications, contact factory.

Canfield Connector

8510 Foxwood Court • Youngstown, OH 44514

STANDARD TERMS OF SALE AND RESTOCKING

1. GENERAL:

- a.) This contract contains the entire agreement between parties and supersedes any prior or contemporaneous oral or written agreements or communications between them relating to the subject matter hereof.
- b.) This contract may not be assigned, modified or cancelled without Seller's prior written consent, and any attempt to assign, modify or cancel it without consent shall be absolutely void.
- c.) No delay or omission to exercise any right, per or remedy accruing to Seller upon breach or default by Buyer under this contract shall impair any such right, power or remedy of Seller, or shall be construed as a waiver of any such breach or default. All waivers must be in writing.
- d.) In the event of any of the provisions hereof shall, for any reason, be held void or unenforceable, the remaining provisions shall remain in full force and effect and shall control.
- e.) Any provisions of this contract prohibited by law of any state shall as to said state, be ineffective to the extent of such prohibition without invalidating the remaining provisions of this contract.
- f.) This contract shall be governed by and construed in accordance with the laws of the State of Ohio, excluding however, Ohio law pertaining to conflicts of law.

2. SELLER'S LIMITED WARRANTY AND LIMITATIONS OF LIABILITIES:

All goods sold hereunder are warranted to be free from defects in material and workmanship for a period of one (1) year from the date of manufacture unless otherwise agreed upon in writing, and to conform to applicable specifications, drawings, blueprints and/or samples. These express warranties are in lieu of and exclude all other warranties, express or implied. Seller's sole obligation under these warranties shall be to issue credit, repair, or replace any item or part thereof which is proved to be other than as warranted; no allowance shall be made for any labor charges of Buyer for replacement of parts, adjustment or repairs, or any other work, unless such charges are authorized in advance by Seller. If goods are claimed to be defective in material or workmanship or not to conform to specifications, drawings, blueprints and/or samples, Seller upon notice promptly given will either examine the goods at their site, or issue shipping instructions for return to Seller (transportation costs prepaid by Buyer). In the event any goods are proved to be other than as warranted, transportation costs to and from Seller's plant will be borne by Seller and reimbursement or credit will be made for amounts so expended by Buyer. In particular, seller makes no warranty respecting the merchantability of the products or their suitability or fitness for any particular purpose or use or respecting infringement. These warranties shall not extend to any goods or parts thereof which have been subjected to misuse or neglect, damage by accident, rendered defective by reason of improper installation or by the performance of repairs or alterations outside of Seller's plant except when performed under Seller's specific authority. These warranties shall not apply to any goods or parts thereof furnished by Buyer or acquired from others at Buyer's request and/or to Buyer's specifications. BUYER SHALL NOT IN ANY EVENT BE ENTITLED TO, AND SELLER SHALL NOT BE LIABLE FOR INDIRECT, SPECIAL, INCIDENTAL OR CONSEQUENTIAL DAMAGES OF ANY NATURE INCLUDING, WITHOUT BEING LIMITED TO, LOSS OF PROFIT, LOSS OF DATA, LOSS OF USE, PROMOTIONAL OR MANUFACTURING EXPENSES, OVERHEAD, INJURY TO REPUTATION OR LOSS OF CUSTOMERS. BUYER'S RECOVERY FROM SELLER FOR ANY CLAIM SHALL NOT EXCEED BUYER'S PURCHASE PRICE FOR THE PRODUCTS IRRESPECTIVE OF THE NATURE OF THE CLAIM, WHETHER IN CONTRACT, TORT, WARRANTY, OR OTHERWISE.

3. PAYMENT:

- a.) Checks are accepted subject to collection and the date of collection shall be deemed the date of payment. Any check received from Buyer may be applied by Seller against any obligation owing by Buyer to Seller, under this or any other contract, regardless of any statement appearing on or referring to such check, without discharging Buyer's liability for any additional amounts owing by Buyer to Seller; and the acceptance by Seller of such check shall not constitute a waiver of Seller's right to pursue the collection of any remaining balance.
- b.) On any invoice not paid by maturity date (net thirty (30) days), Buyer shall pay interest from maturity to date of payment at the annual percentage rate of 18% (or such lower rate as may be the maximum allowable by law), together with Seller's costs of collection (including reasonable attorneys' fees).
- c.) Buyer agrees to pay the entire net amount of each invoice rendered by Seller pursuant to the terms of each such invoice without offset or deduction.
- d.) Prices for any undeliverable Products may be increased by Seller in the event of any increase in Seller's cost of supplies, raw materials, labor or services, or any increase in Seller's cost resulting from government action or other cause beyond Seller's control.

4. CREDIT:

Seller may in its sole discretion at any time and from time to time change the terms of Buyer's credit, require payment in cash before shipment of any or all of the Products specified herein, and/or require anticipated payment of any or all amounts due or to become due under this contract. If Seller believes in good faith that Buyer's ability to make payments called for by this contract is or may be impaired, Seller may cancel this contract or any remaining balance thereof, Buyer remaining liable to pay for any Products already shipped.

5. TAXES/FREIGHT:

Unless otherwise agreed in writing, the amount of all transportation charges from Seller's location and all taxes or other charges now or hereafter imposed by any government authority upon sale, purchase, resale, delivery, manufacture, production or possession of the Products specified herein, which may be paid by Seller or for which Seller may be liable, shall be paid to Seller by Buyer in addition to the purchase price of the Products.

6. ORDERS:

- a.) Each order for Products is subject to acceptance in writing by Seller.
- b.) Orders may not be cancelled or rescheduled after delivery by Seller to the carrier. In the event of allocation of Products, orders that are accepted by Seller will be accepted using a fair schedule method.
- c.) Special Orders - Special orders for items not normally stocked are non-cancelable and non-returnable.

7. DELIVERIES/TITLE:

- a.) All goods shall be packed in suitable containers for protection in shipment and storage. No special charges for packing or crating shall be made unless specifically listed as an additional and separate charge on Seller's quotation or acceptance of Buyer's order.
- b.) Subject to Seller's right of stoppage in transit, delivery of the Products to a carrier shall constitute delivery to Buyer, and risk of loss shall thereupon pass to Buyer; however, title shall remain in Seller until Buyer makes payment in full under contract. Products invoiced and held by Seller for any reason shall be at Buyer's risk and expense. Delivery route shall be the election of Seller unless specifically designated by Buyer.

- c.) Delivery of any installment of Products within 30 days after the date specified therefor shall constitute a timely delivery. Thereafter, delivery shall be deemed timely unless prior to shipment Seller has received written notice of cancellation. Delivery of a quantity which does not vary by more than 10% from the quantity specified therefor shall constitute full performance of such delivery. Delay in delivery of one installment shall entitle Buyer to cancel that installment only.
- d.) Should delivery of all or part of the Products specified herein (or any other obligation of Seller) be delayed by events beyond Seller's control, Seller's time for performance shall be extended by the period of delay, or Seller may, at its option, cancel this contract without liability, Buyer remaining liable for shipments already made. Sellers shall not be liable for any delays in or failures of delivery due to acts of God or public authority, labor disturbances, accidents, fires, floods, extreme weather conditions, failures of and delays by carriers, shortages of material, delays of a supplier due to causes beyond its control.
- e.) Buyer is deemed to have accepted the Products unless notice of rejection is given within a reasonable time, which is agreed to be within seven (7) days after receipt. Buyer waives any right to revoke acceptance thereafter.
- f.) No return of Products will be accepted by Seller without a return materials authorization number (RMA#), which will be issued in Seller's sole discretion. Returned Products must be in original shipping cartons, and must be freight prepaid. In the event any goods are proved to be other than as warranted, transportation costs to and from Seller's plant will be borne by Seller and reimbursement or credit will be made for amounts so expended by Buyer. Notice of defective Products must be made within seven (7) calendar days of receipt. A complete description regarding the nature of the defect must be included with all returned Products. All items not eligible for credit will be returned to Buyer, transportation collect.

8. SPECIFICATIONS AND DESIGNS:

- a.) Should Buyer request that changes be made in the specifications or design relating to any goods, delivery dates and schedules shall be revised accordingly, if necessary, and an equitable adjustment, upward or downward, shall be made in price in so far as warranted.
- b.) Any designs, tools, patterns, material, drawings, information or equipment furnished by Buyer, or any special tools made or acquired for the Buyer by the Seller which becomes Buyer's property, shall be used only in the production of the goods called for herein and not otherwise, unless by Buyer's written consent. Seller agrees to exercise reasonable care with respect to such property and equipment while in its possession and control, but shall not be responsible for loss or damage occurring without its fault or negligence or for ordinary wear and tear.

9. USE OF PRODUCTS:

- a.) If technical advice is offered or given in connection with the use of any Products it will be as an accommodation to Buyer and without charge and Seller shall have no responsibilities or liabilities whatsoever for the content or use of such advice.
- b.) Products sold by Seller are not designed for use in life support or nuclear applications. Seller's customers using or selling Products for use in life support or nuclear applications do so at their own risk, agree that Seller and the Manufacturer of Products are not liable, in whole or in part, for any claim or damage arising from such use, and agree to fully indemnify Seller and the Manufacturer from and against any and all damages, loss, cost, expense or liability arising out of or in connection with the use or performance of Products in life support or nuclear applications.
- c.) Should the Buyer notify the Seller that its order is placed under a prime contract with an agency of the United States Government, the following terms and conditions shall be incorporated into Seller's terms of sale in so far as the Buyer is required to incorporate such provisions in its purchase orders or subcontracts of terms in so far as applicable to the goods sold hereunder.
- d.) The following clause set forth or referred to in Sections 7 and 12 of the Armed Services Procurement Regulations are hereby incorporated by reference: Renegotiation (7-103.13), Eight Hour Law of 1912 (7-103.16 12-303.1), Walsh-Healy Public Contracts Act (7-103.17 12-604), Nondiscrimination in Employment (7-103.18 12-802), Officials Not to Benefit (7-103.19), Buy American Act (7-104.3 6-104.5), Notice to the Government of Labor Disputes (7-104.4), Excess Profit (7-104.11), Military Security Requirements (7-104.12), Examination of Records (7-104.15), Convict Labor (7-104.17 12-203). In order to make the context of the above clauses applicable to these terms of sale, the word "Buyer" shall be substituted for the word "Government" and the word "Seller" shall be substituted for the word "contractor" whenever necessary.
- e.) Unless the design for the goods shall have been furnished by the Buyer to the Seller and used by the Seller in manufacturing the goods, Seller shall defend and save harmless the Buyer from any claim that any product or article sold to the Buyer hereunder in and of itself infringes any United States letters patent by reason of its sale or use/ provided Seller is notified in writing within ten (10) days after any such claim is made against the Buyer, and provided further that Seller is permitted to defend the same in Buyer's name if action be brought. If the product or article sold to the Buyer hereunder is manufactured by the Seller according to a design furnished by the Buyer, the Buyer will defend and save harmless the Seller from any claims of infringement of any United States Letters patent.

10. TOOLING:

Tool, die, and pattern charges, if any, are in addition to the price of the Goods and are due and payable upon completion of the tooling. All such tools, dies and patterns shall be and remain the property of Seller. Charges for tools, dies, and patterns do not convey to Buyer, title, ownership interest in, or rights to possession or removal, or prevent their use by Seller for other purchasers, except as otherwise expressly provided by Seller and Buyer in writing with reference to this provision.

11. INSTALLATION/TRAINING:

Buyer acknowledges that no installation, training or education is contracted for or purchased under terms of this contract unless specifically agreed in writing. In the event that Buyer receives any training from Seller with respect to the Products, then, in that event, such training is personal to the persons receiving such training, and Buyer acknowledges that any persons receiving such training may not be capable of operating the Products.

12. RESTOCKING POLICY:

Merchandise that is returned must be accompanied by pre-approved return materials authorization number (RMA#). Return authorizations will be approved by Canfield Connector. When materials are received, an inspection will be performed to determine if restocking charges are applicable. Material that does not have an authorization will be returned to the purchaser at their expense.

RETURNED ITEMS MAY ENTAIL A RESTOCKING CHARGE. CONSULT FACTORY FOR EXACT RESTOCKING FEES. AS CHARGES MAY VARY DEPENDING ON THE AMOUNT OF SPECIALTY OF THE ITEMS BEING RETURNED.

CUSTOM PARTS & "9-" NUMBERS ARE NON-RETURNABLE AND NON-REFUNDABLE (EXCEPT IN CASES OF WARRANTY)

Table of Contents

Solenoid Valve Connectors and Accessories

5	5F - Molded Solenoid Valve Connectors
7	5J - Molded Solenoid Valve Connectors
9	5K - Molded Solenoid Valve Connectors
11	5FFAC - Fieldbus Adapter Molded Solenoid Valve Connectors
13	5JFAC - Fieldbus Adapter Molded Solenoid Valve Connectors
15	5FMSD - Molded Solenoid Valve Connectors with In-line Micro Solenoid Driver Power Converter
17	5JMSD - Molded Solenoid Valve Connectors with In-line Micro Solenoid Driver Power Converter
19	5FR - Rectified Molded Solenoid Valve Connectors
21	5JR - Rectified Molded Solenoid Valve Connectors
23	5JGT - DIN to GT Adapter
25	GT - Molded Receptacle and Plug Connectors
27	MCCR - Multiple Control Connector
29	5000 - MINI Field Wireable Solenoid Valve Connectors
31	5000 - ISO Field Wireable Solenoid Valve Connectors
33	5000 - Sub-Micro Field Wireable Solenoid Valve Connectors
35	FAC - 7/8" Automotive Fieldbus Adapter Solenoid Valve Connectors
37	FAC - 12mm Fieldbus Adapter Solenoid Valve Connectors
39	P5600 - Micro Protective Connectors with Surge Suppression
43	R5000 - ISO Rectified Solenoid Valve Connectors
45	M5 - Male Connectors
48	iLW - Interposed Lighted Wafer Indicator Light for Connectors
49	DCP - Solenoid Valve DIN Coil Protectors
50	CanGrip - Cord Grips

Round Connectors

54	Round Connectors - Field Wireable or Molded Locking For Use with Proximity Devices
----	--

Cylinder Proximity and Inclinometer Sensors

56	7000 - Reed & Electronic Sensors for Tie-rod and Round Cylinders
58	7C - Reed & Electronic Sensors for Tie-rod Cylinders
60	7GL - General Location Sensors for Tie-rod Cylinders
61	7HL - Hazardous Location Sensors for Tie-rod Cylinders
62	8000 - Reed & Electronic Sensors for Tie-rod, Round or Extruded Cylinders
64	8WS - Reed & Electronic Sensors for 12mm Dovetail Applications
66	9C - Reed & Electronic Sensors for Round Keyway Applications
68	9D - Reed & Electronic Sensors for Universal Applications
70	9E - Reed & Electronic Sensors for Universal Applications
72	9F - Reed & Electronic Sensors for 4mm "T" Slot Applications
74	9G - Reed & Electronic Sensors for 6.3mm "T" Slot Applications
76	9H - Reed & Electronic Sensors for 4.2mm "T" Slot Applications
78	9K - Reed & Electronic Sensors for 4.2mm "U" Slot Applications
81	9M50 - Reed & Electronic Sensors for 6.5mm Groove Applications
82	9Q - Reed & Electronic Sensors for Universal "T" Slot Applications
84	9T - Reed & Electronic Sensors for 7.2mm "T" Slot Applications
86	CS - All Threaded Sensors for Universal Applications
88	EIS - Electronic Inclinometer Sensor

Proportional Drivers, Timers and Electronic Circuits

90	D5400 - Micro Solenoid Driver (MSD)
92	5800 - Micro Logic Timer (MLT)
96	5950 - Micro Proportional Driver (MPD)
98	B5950 - Block-Style Micro Proportional Driver
100	Sandwich CRT - Sandwich-Style Condensation Removal Timer
102	MBT - Multifunction Block Timer
106	TMLT - Micrologic Timer Module

Conveyor Controls

110	OSV - Optical Sensor Valve Photo-eye Accumulation System
-----	--

Additional Information

113	Product Sample Case
114	Custom Capabilities
115	Connector Orientation Options
116	Gasket Detail Options
117	Sensor / Groove Cross Reference Chart
118	Wire Installation
119	Wire Terminology
120	OHMS Law
121	Environmental Protection Classifications
122	Units and Conversions
123	Glossary of Terms

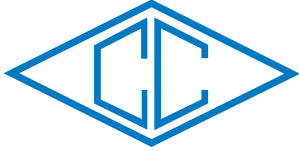

canfield connector
 8510 Foxwood Court
 Youngstown, Ohio 44514
 P:(330) 758-8299 F:(330) 758-8912
 www.canfieldconnector.com

Connectors and Accessories

5F SERIES

LIGHTED AND LOAD SUPPRESSED MOLDED MINI, ISO AND SUB-MICRO SOLENOID VALVE CONNECTORS

General Description

The Canfield 5F Series all-molded DIN solenoid valve connector/gasket/cord assembly offers a completely molded design that is far better for environmental integrity than field wire versions. Made from rugged yet flexible polyurethane, the connector housing boasts high durability factors and application versatility. The low profile “straight-line” interface/cord configuration allows for installation in many limited space applications. The integrated gasket design boasts an IP67/NEMA 6 rating and makes it impossible to lose the gasket. The 5F and 5J are the only molded valve connectors in the industry that feature a Hard Usage cord option in any length required, bi-directional indicator lights, and load suppression (not intended for UL 1449). UL and CSA versions are available as well. Canfield offers any version of the 5F connector with special wires including high flex, media compatible wire, special use wire, high temperature wire on request.

Dimensional Data

ALL DIMENSIONS ARE IN MILLIMETERS UNLESS OTHERWISE NOTED



ISO, Lighted version shown above

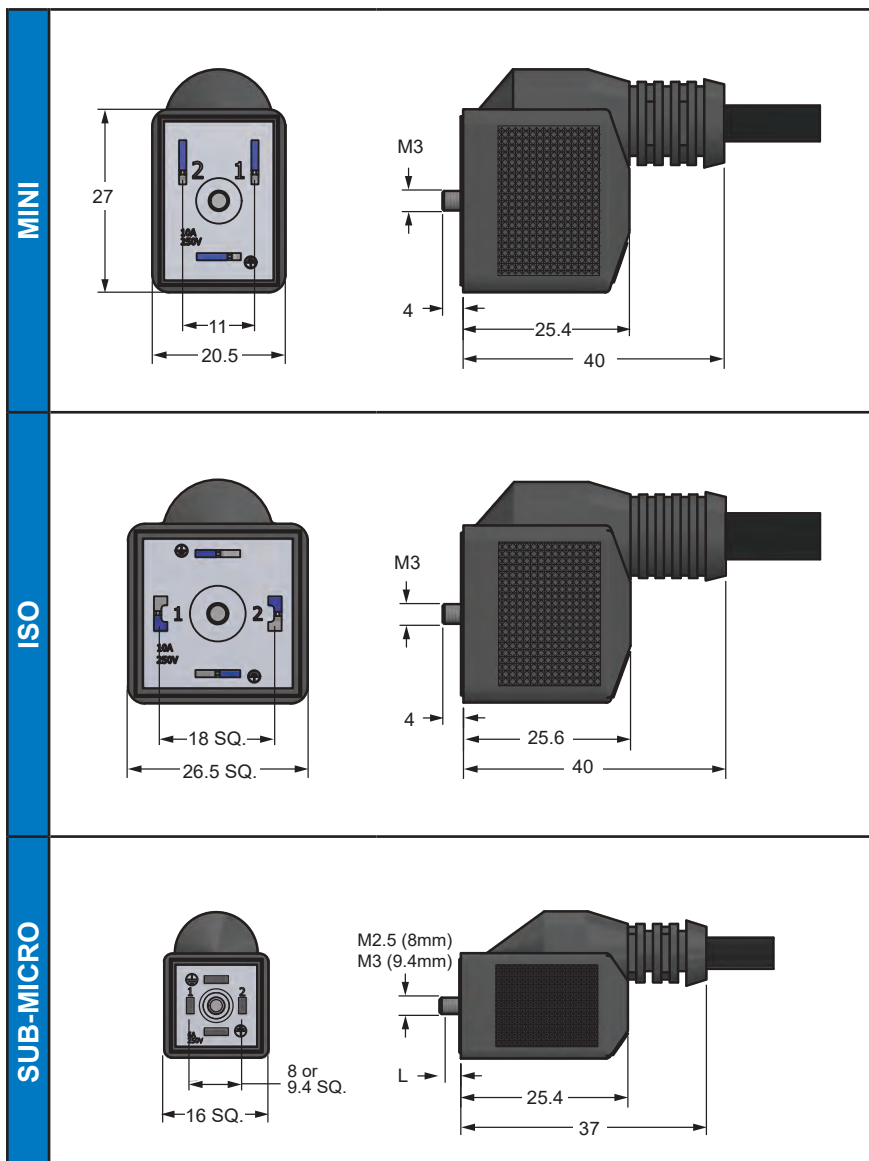

Consult factory for available versions recognized under the Component Program of Underwriters Laboratories, Inc.



Consult factory for available versions listed by Canadian Standards Association for use with certified electrical equipment.

Technical Data

Current Max.	ISO / MINI: 10 Amps Sub-Micro: 6 Amps
Voltage Max.	250 VAC 50/60 Hz, 300 VDC
Materials	Enclosure: Polyurethane Gasket: Polyurethane
Temperature Range	-25° to +80°C
Environmental Protection	IP 67 AND NEMA 6, Dust tight and water resistant
Cable Diameter	ISO / MINI, EU (European) / US (U.S.A.): 0.275 ISO / MINI, HU (Hard Usage): .300 Sub-Micro, EU (European) / US (U.S.A.): 0.190
Cable Conductor Colors	EU Code: Blue, brown, yellow/green (4th conductor version black) US Code: Black, green, white (4th conductor version red) (Others available on request)
Cable Type	Pressure extruded PVC jacket Hard usage cordage "S" type with SJTOW standard PVC jacket (ISO & MINI only) (Others available on request)
Wire Gauge	ISO / MINI: 18 AWG standard Sub-Micro: 20 AWG standard
Size	ISO 18mm pin spacing - DIN Style "A" EN175301-803 MINI 11mm pin spacing - Industry Standard Sub-Micro 8mm pin spacing - DIN Style "C" EN 175301-803 Sub-Micro 9.4mm pin spacing - Industry Standard
Number of Contacts	MINI / ISO / Sub-Micro: 2+ ground ISO / Sub-Micro: 3+ ground

NOTE: Slight discoloration may occur to translucent material after prolonged exposure to UV rays.
NOTE: When using MAC Valves with MINI and 9.4mm Sub-Micro, consult our factory.

Wiring Information

TERMINAL CONFIGURATION		
Wire Type	EUR	US / HU
⊖ Chassis Ground	YEL & GRN	GRN
(+) Pos. / Hot Pin 1	BRN	BLK
(-) Neg. / Neut. Pin 2	BLU	WHT
Signal Pin 3	BLK	RED

Ordering Information

All connectors come standard with integrated gasket and screw.

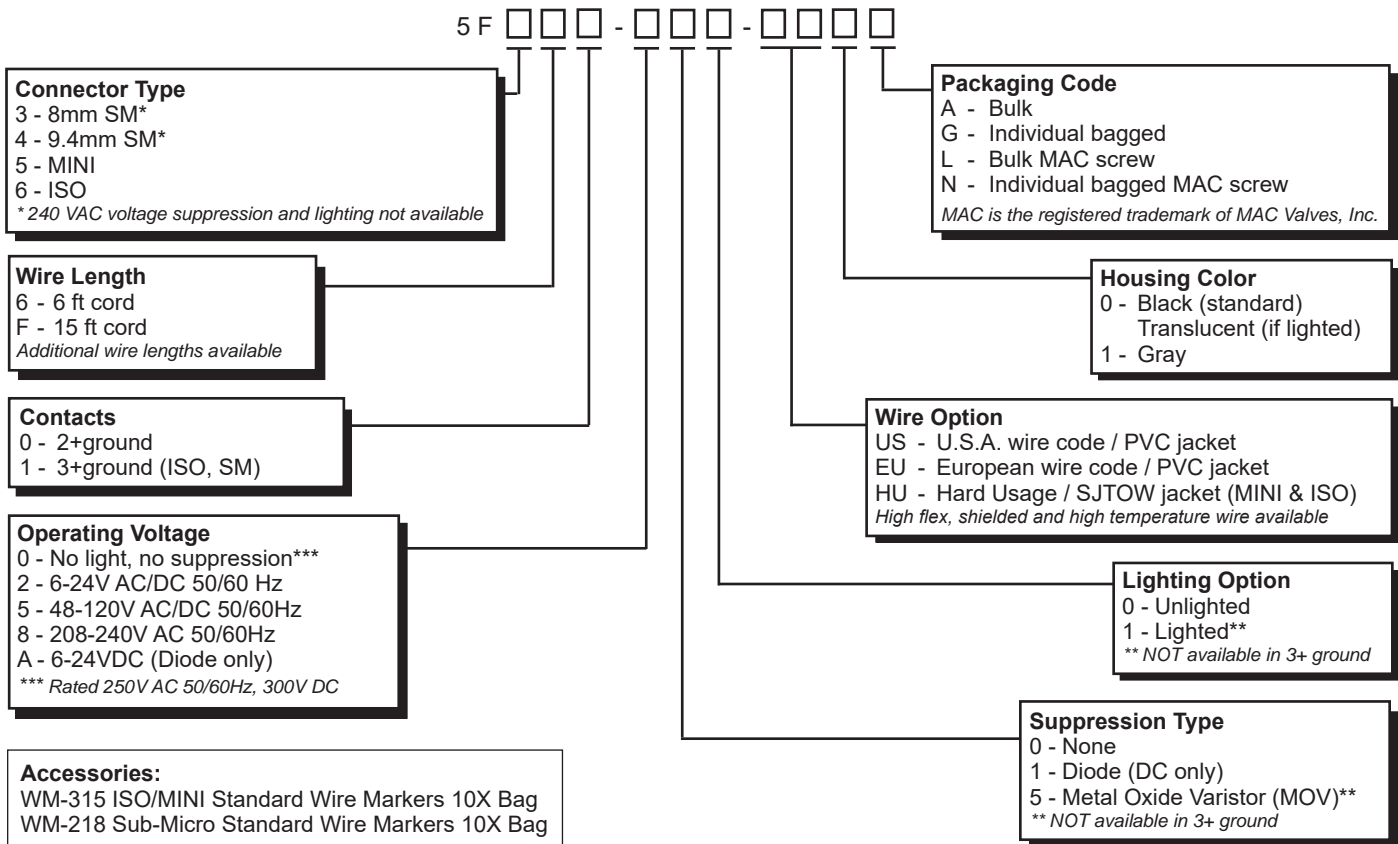

For convenience and faster shipping,
this series is available in Can-Paks.



Ordering Example: 5F660-251-US0A

ISO, 6 ft wire length, 2+ ground, 6-24V AC/DC 50/60 Hz, MOV, lighted, U.S.A. wire code / PVC jacket, standard housing color, bulk

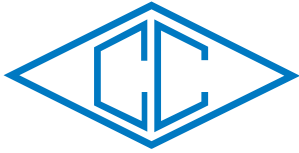

canfield connector
 8510 Foxwood Court
 Youngstown, Ohio 44514
 P:(330) 758-8299 F:(330) 758-8912
 www.canfieldconnector.com

5J SERIES

LIGHTED AND LOAD SUPPRESSED MOLDED MINI, ISO AND SUB-MICRO SOLENOID VALVE CONNECTORS

General Description

The Canfield 5J Series all-molded DIN solenoid valve connector/gasket/cord assembly offers a completely molded design that is far better for environmental integrity than field wire versions. Made from rugged yet flexible polyurethane, the connector housing boasts high durability factors and application versatility. The low profile "90°" interface/cord configuration allows for installation in many limited space applications. The integrated gasket design boasts an IP67/NEMA 6 rating and makes it impossible to lose the gasket. The 5J and 5F are the only molded valve connectors in the industry that feature a Hard Usage cord option in any length required, bi-directional indicator lights, and load suppression (not intended for UL 1449). UL and CSA versions are available as well. Canfield offers any version of the 5J connector with special wires including high flex, media compatible wire, special use wire, high temperature wire on request.

Dimensional Data

ALL DIMENSIONS ARE IN MILLIMETERS UNLESS OTHERWISE NOTED

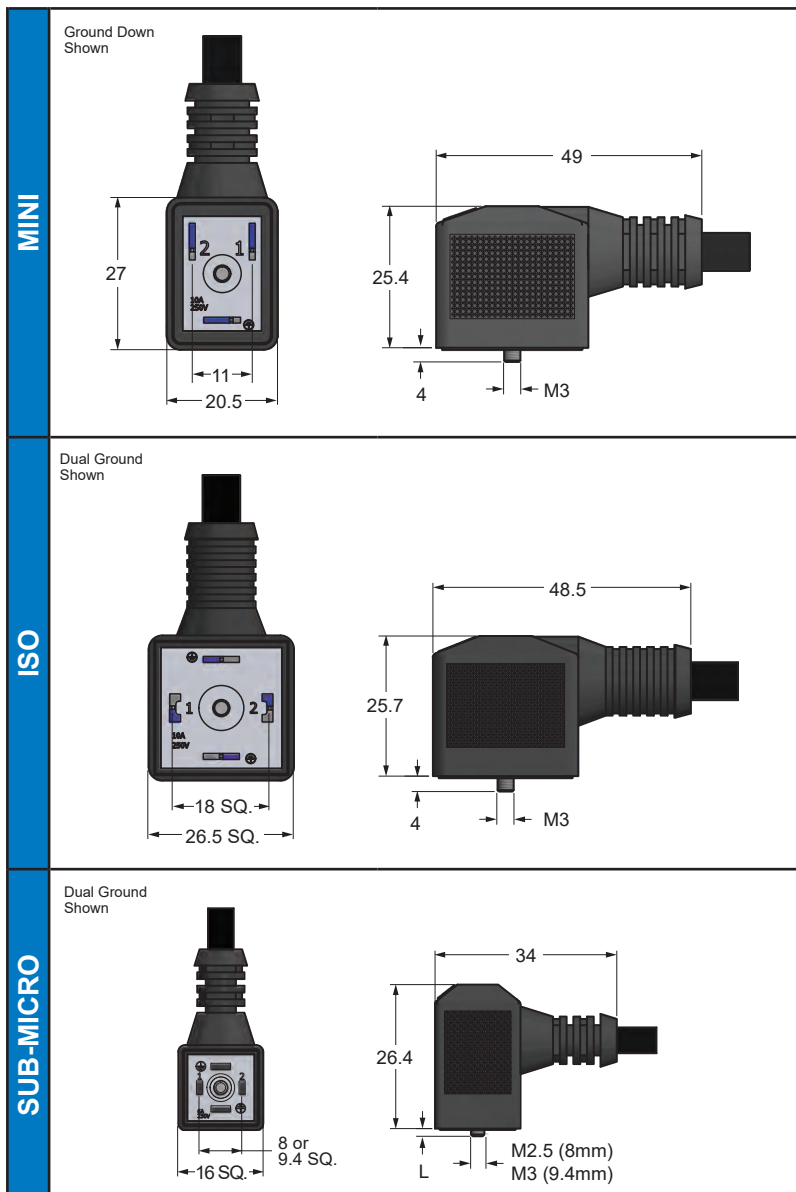

Consult factory for available versions recognized under the Component Program of Underwriters Laboratories, Inc.



Consult factory for available versions listed by Canadian Standards Association for use with certified electrical equipment.

Technical Data

Current Max	ISO / MINI: 10 Amps Sub-Micro: 6 Amps
Voltage Max.	250 VAC 50/60 Hz, 300 VDC
Materials	Enclosure: Polyurethane Gasket: Polyurethane
Temperature Range	-25° to +80°C
Environmental Protection	IP 67 AND NEMA 6, Dust tight and water resistant
Cable Diameter	ISO / MINI: EU (European) / US (U.S.A.): 0.275 ISO / MINI: HU (Hard Usage): .300 Sub-Micro: EU (European) / US (U.S.A.): 0.190
Cable Conductor Colors	EU Code: Blue, brown, yellow/green (4th conductor version black) US Code: Black, green, white (4th conductor version red) (Others available on request)
Cable Type	Pressure extruded PVC jacket Hard usage cordage "S" type with SJTOW standard PVC jacket (ISO & MINI only) (Others available on request)
Wire Gauge	ISO / MINI: 18 AWG standard Sub-Micro: 20 AWG standard
Size	ISO: 18mm pin spacing - DIN Style "A" EN175301-803 MINI: 11mm pin spacing - Industry Standard Sub-Micro: 8mm pin spacing - DIN Style "C" EN 175301-803 Sub-Micro: 9.4mm pin spacing - Industry Standard
Number of Contacts	MINI / ISO / Sub-Micro: 2+ ground ISO / Sub-Micro: 3+ ground

Wiring Information

TERMINAL CONFIGURATION		
Wire Type	EUR	US / HU
⊕ Chassis Ground	YEL & GRN	GRN
(+) Pos. / Hot Pin 1	BRN	BLK
(-) Neg. / Neut. Pin 2	BLU	WHT
Signal Pin 3	BLK	RED

NOTE: Slight discoloration may occur to translucent material after prolonged exposure to UV rays.
NOTE: When using MAC Valves with MINI and 9.4mm Sub-Micro, consult our factory.

Ordering Information

All connectors come standard with integrated gasket and screw.

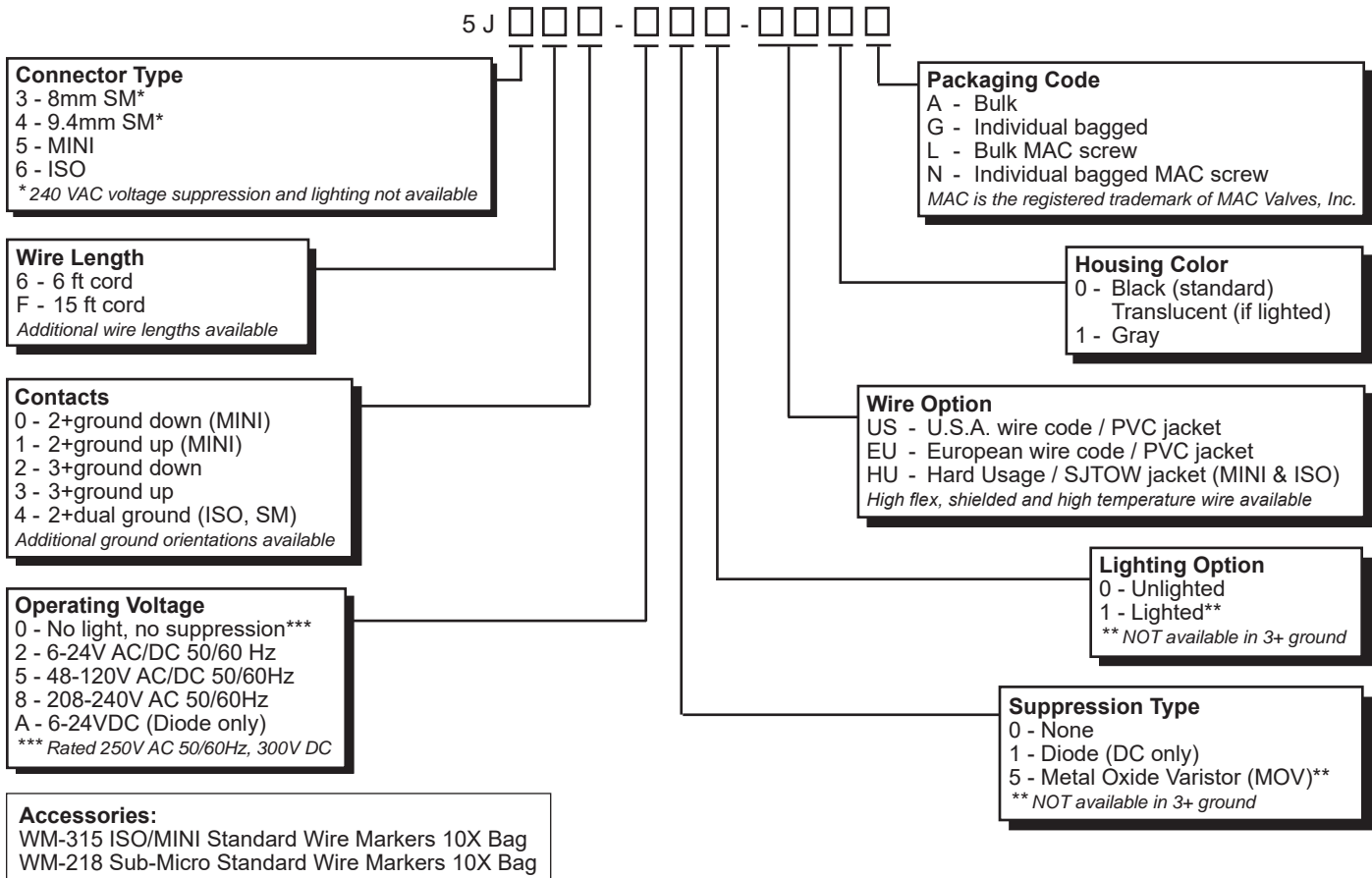

For convenience and faster shipping, this series is available in Can-Paks.



Ordering Example: 5J664-251-US0A

ISO, 6 ft wire length, 2+ dual ground, 6-24V AC/DC 50/60 Hz, MOV, lighted, U.S.A. wire code / PVC jacket, standard housing color, bulk w/ Canfield p/n

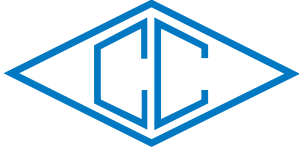

canfield connector
 8510 Foxwood Court
 Youngstown, Ohio 44514
 P:(330) 758-8299 F:(330) 758-8912
 www.canfieldconnector.com

5K SERIES

LIGHTED AND LOAD SUPPRESSED MOLDED ISO SOLENOID VALVE CONNECTORS

General Description

The Canfield Connector 5K Series DIN solenoid valve connector all molded cord assembly offers a rugged one-piece design that is far better for environmental integrity than field wire solenoid valve connectors. Made from rugged yet flexible polyurethane, the connector housing boasts high durability factors and application versatility. The low profile “90°” interface/cord configuration allows for installation in many limited space applications. The 5K Series is different than the 5J Series version and is offered without the integrated gasket design in order to promote version compatibility as with the Canfield Connector MCCR and iLW. The 5K boasts an IP67/NEMA 6 rating when gasket is applied. The 5K Series as well as the 5F Series and 5J Series are the only molded valve connectors in the industry that feature a Hard Usage cord option in any length required, bi-directional indicator lights, and load suppression (not intended for UL 1449), and is Proudly Made in the U.S.A.

Dimensional Data

ALL DIMENSIONS ARE IN MILLIMETERS UNLESS OTHERWISE NOTED



ISO, Unlighted version shown above

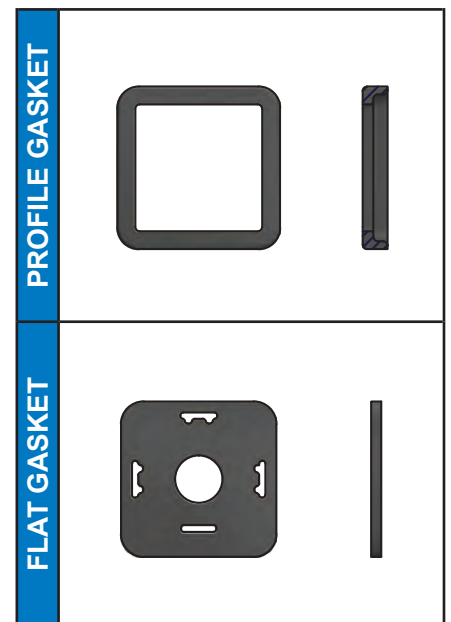
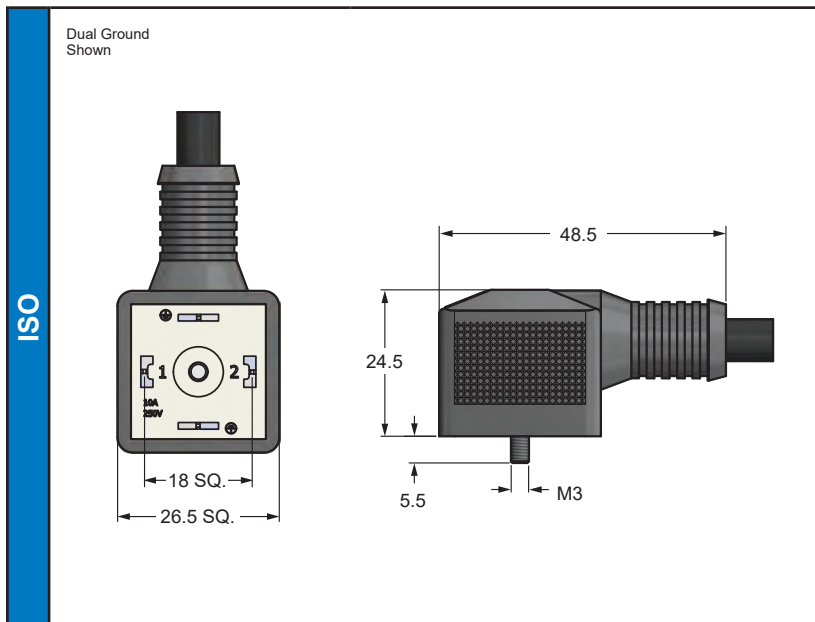

Technical Data

Current Max.	10 Amps
Voltage Max.	250 VAC 50/60 Hz, 300 VDC
Materials	Enclosure: Polyurethane Gasket: Nitrile, Silicone
Temperature Range	-25° to +80°C
Environmental Protection	IP 67 AND NEMA 6, Dust tight and water resistant (with gasket)
Cable Diameter	ISO / MINI: EU (European) / US (U.S.A.): 0.275 ISO / MINI: HU (Hard Usage): .300 Sub-Micro: EU (European) / US (U.S.A.): 0.190
Cable Conductor Colors	EU Code: Blue, brown, yellow/green (4th conductor version black) US Code: Black, green, white (4th conductor version red) (Others available on request)
Cable Type	Pressure extruded PVC jacket Hard usage cordage "S" type with SJTOW standard PVC jacket (Others available on request)
Wire Gauge	18 AWG standard
Size	ISO: 18mm pin spacing - DIN Style "A" EN175301-803
Number of Contacts	2+ ground 3+ ground

NOTE: Slight discoloration may occur to translucent material after prolonged exposure to UV rays.

Wiring Information

TERMINAL CONFIGURATION		
Wire Type	EUR	US / HU
⊖ Chassis Ground	YEL & GRN	GRN
(+) Pos. / Hot Pin 1	BRN	BLK
(-) Neg. / Neut. Pin 2	BLU	WHT
Signal Pin 3	BLK	RED

Ordering Information

All connectors come standard with screw.

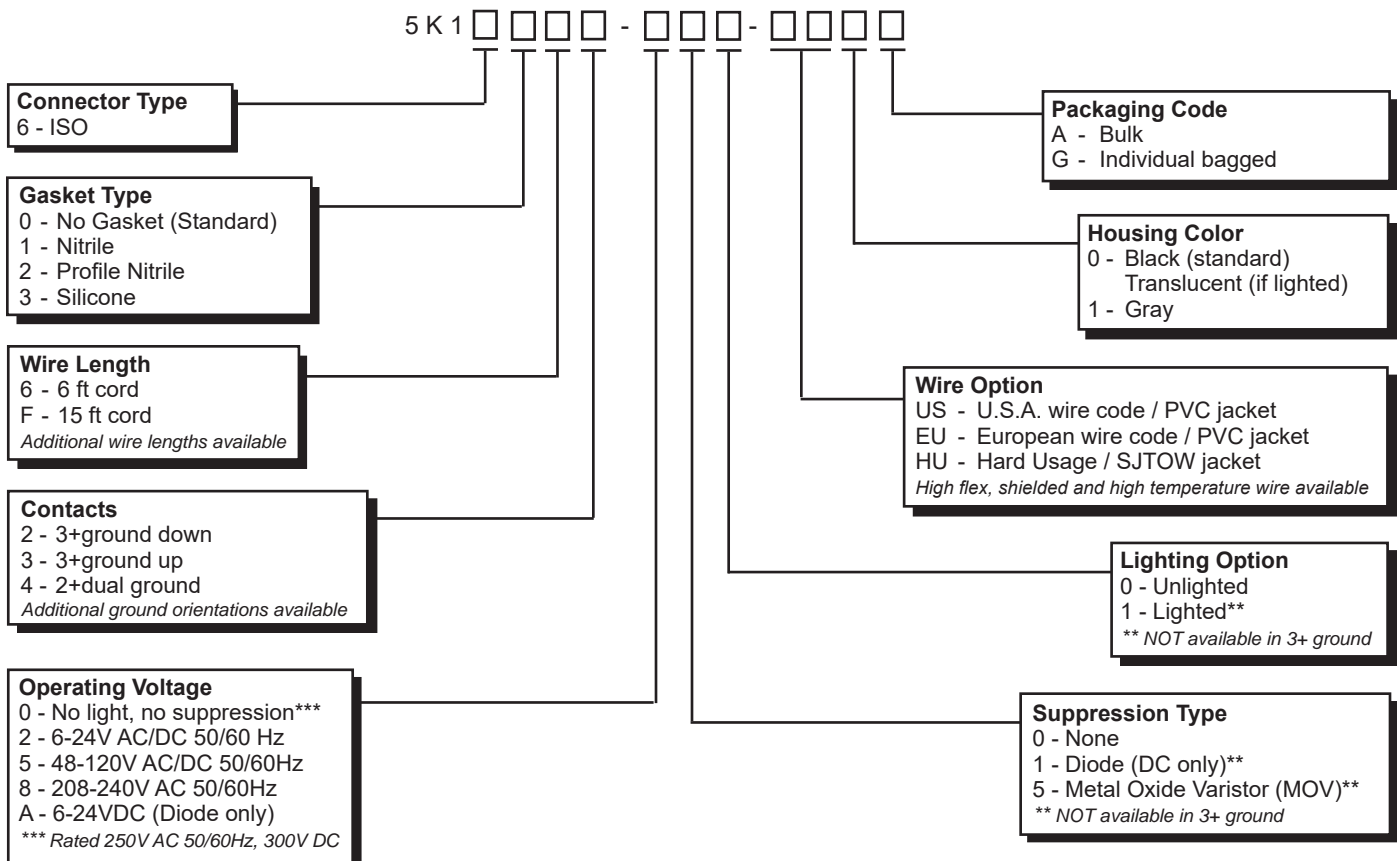

Accessories:
WM-315 ISO/MINI Standard Wire Markers 10X Bag

Ordering Example: 5K16064-251-US0A

ISO, No Gasket, 6 ft wire length, 2+ dual ground, 6-24V AC/DC 50/60 Hz, MOV, lighted, U.S.A. wire code / PVC jacket, Black standard housing color, Bulk packaged

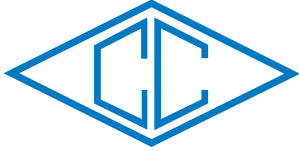

5FFAC SERIES

**FIELD BUS ADAPTER
 SOLENOID VALVE CONNECTORS**

General Description

The Canfield 5FFAC Series all-molded DIN solenoid valve connector/gasket/cord offer a completely molded plug and play design that interfaces female ISO DIN Style "A" EN175301-803 (Formerly DIN 43650), MINI and 9.4mm (Industry Standard) and 8mm Sub-Micro (DIN 43650 "C") solenoid connections to 8mm or 12mm (round) circular connectors as shown on the following pages. Made from rugged yet flexible polyurethane, the connector housing boasts high durability factors and application versatility. The low profile "straight line" interface/cord configuration allows for installation in many limited space applications. The integrated gasket design boasts an IP67/NEMA 6 rating, is far better for environmental integrity than field wire versions and makes it impossible to lose the gasket! The 5FFAC and 5JFAC are the only molded valve connectors in the industry that feature bi-directional indicator lights and load suppression (not intended for UL 1449). The 5FFAC Series is proudly made in the U.S.A.

Dimensional Data

ALL DIMENSIONS ARE IN MILLIMETERS UNLESS OTHERWISE NOTED

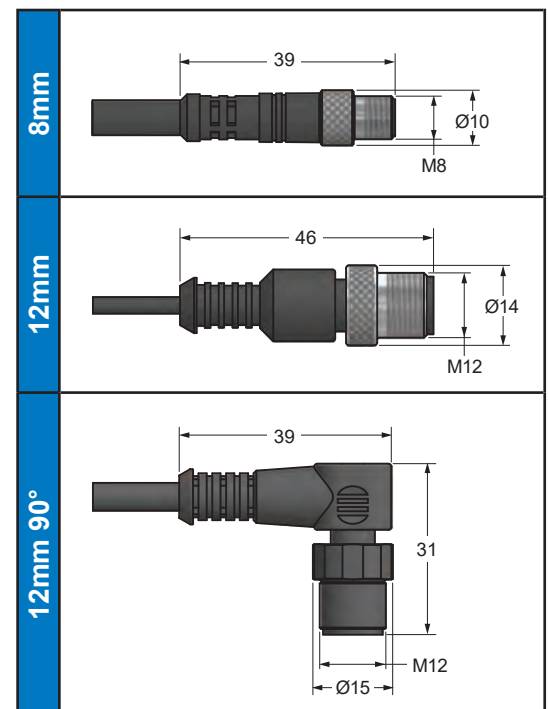
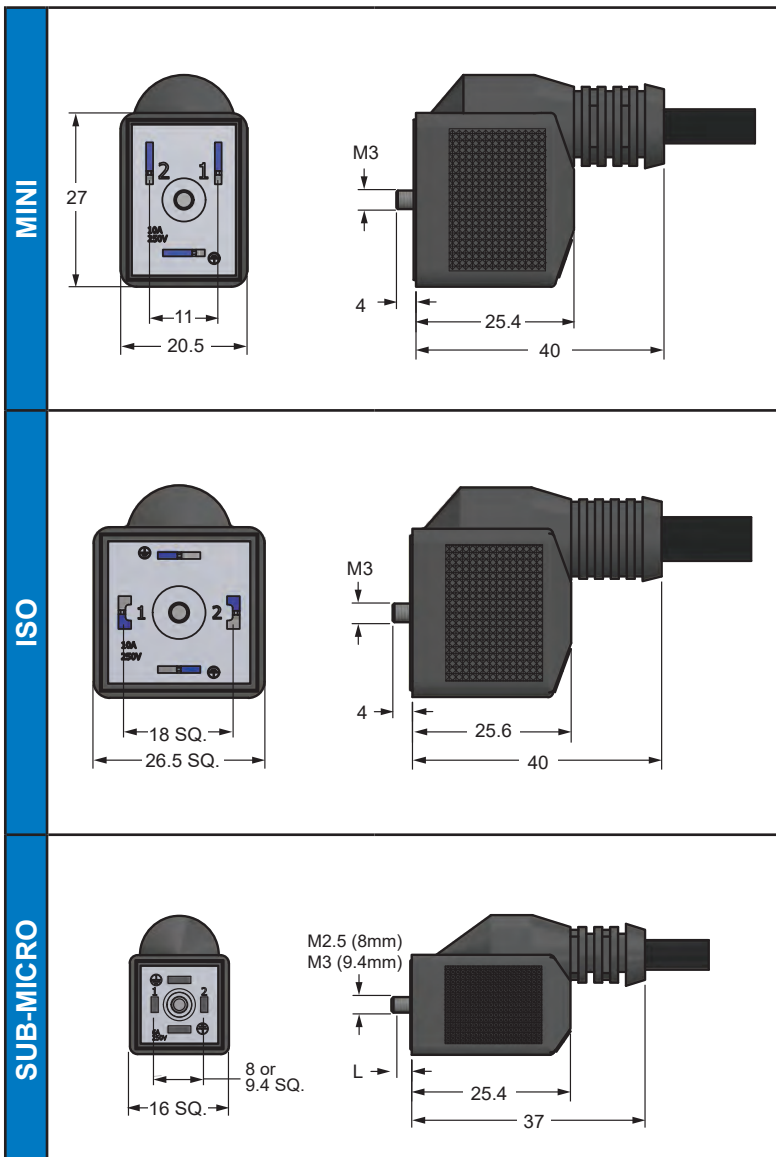

Technical Data

Current Max.	Continuous: 4 Amps Inrush: 10 Amps for 15 ms
Voltage Max.	120 V AC/DC 50/60 Hz
Voltage Drop	2.2 Volts Max.
Materials	Enclosure: Polyurethane (Black or Translucent) Gasket: Polyurethane
Temperature Range	-25° to +80°C
Environmental Protection	IP 67 AND NEMA 6, Dust tight and water resistant
Cable Type	Pressure extruded PVC jacket or PUR with & without shield (Others available on request)
Size	ISO: 18mm pin spacing - DIN Style "A" EN175301-803 MINI: 11mm pin spacing - Industry Standard Sub-Micro: 8mm pin spacing - DIN Style "C" EN 175301-803 Sub-Micro: 9.4mm pin spacing - Industry Standard
Number of Contacts	2+ ground

NOTE: Slight discoloration may occur to translucent material after prolonged exposure to UV rays.
NOTE: When using MAC Valves with MINI and 9.4mm Sub-Micro, consult our factory.

Wiring Information

TERMINAL CONFIGURATION		
Wire Type	EUR	US / HU
⊖ Chassis Ground	YEL & GRN	GRN
(+) Pos. / Hot Pin 1	BRN	BLK
(-) Neg. / Neut. Pin 2	BLU	WHT
Signal Pin 3	BLK	RED

Circuit Types

	0-120V AC/DC	6-24V DC	6-120V AC/DC
3-4 Pin			
5 Pin			

Pin Configuration



Ordering Guide

All connectors come standard with integrated gasket and screw.

5 F F A C - [] [] 0 - [] [] [] - [] []

Connector Type
3 - 8mm SM
4 - 9.4mm SM
5 - MINI
6 - ISO

Wire Length
U - 2 Meter
X - 5 Meter
Additional wire lengths available

Operating Voltage
0 - No light, no suppression*
2 - 6-24V AC/DC 50/60 Hz
5 - 48-120V AC/DC 50/60Hz
A - 6-24VDC (Diode only)
** Rated 120V AC/DC 50/60Hz*

Suppression Type
0 - No light, no suppression*
1 - Diode (DC only)
5 - Metal Oxide Varistor (MOV)
** Rated 120V AC/DC 50/60Hz*

Packaging Code
A - Bulk
G - Individual bagged
L - Bulk MAC screw
N - Individual bagged MAC screw
MAC is the registered trademark of MAC Valves, Inc.

Wire / Circuit Type

Wire / Circuit Type	Coding
0 - M12 3 Pin male Straight	A
1 - M12 3 Pin male 90°	A
2 - M12 4 Pin male Straight	A
3 - M12 4 Pin male 90°	A
4 - M12 5 Pin male Straight	A
5 - M12 5 Pin male 90°	A
6 - M8 3 Pin male Straight	A

Wire Type
0 - PVC
1 - PUR

Ordering Example: 5FFAC-3U0-250-2A
8mm SM, 2 meter wire length, 6-24V AC/DC 50/60 Hz, lighted, MOV, PVC wire type, M12, 4 pin, male, Straight, Bulk

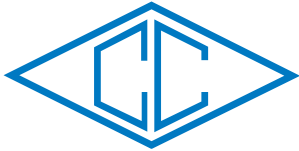

5JFAC SERIES

**FIELD BUS ADAPTER
 SOLENOID VALVE CONNECTORS**

General Description

The Canfield 5JFAC Series all-molded DIN solenoid valve connector/gasket/cord offer a completely molded plug and play design that interfaces female ISO DIN Style "A" EN175301-803 (Formerly DIN 43650), MINI and 9.4mm (Industry Standard) and 8mm Sub-Micro (DIN 43650 "C") solenoid connections to 8mm or 12mm (round) circular connectors as shown on the following pages. Made from rugged yet flexible polyurethane, the connector housing boasts high durability factors and application versatility. The low profile "90°" interface/cord configuration allows for installation in many limited space applications. The integrated gasket design boasts an IP67/NEMA 6 rating, is far better for environmental integrity than field wire versions and makes it impossible to lose the gasket! The 5FFAC and 5JFAC are the only molded valve connectors in the industry that feature bi-directional indicator lights and load suppression (not intended for UL 1449). The 5JFAC Series is proudly made in the U.S.A.

Dimensional Data

ALL DIMENSIONS ARE IN MILLIMETERS UNLESS OTHERWISE NOTED



ISO, Lighted, M8 Straight version shown above

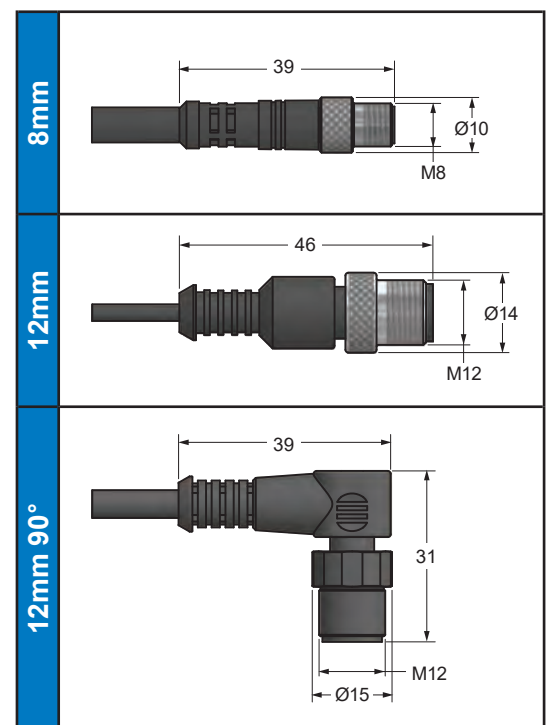
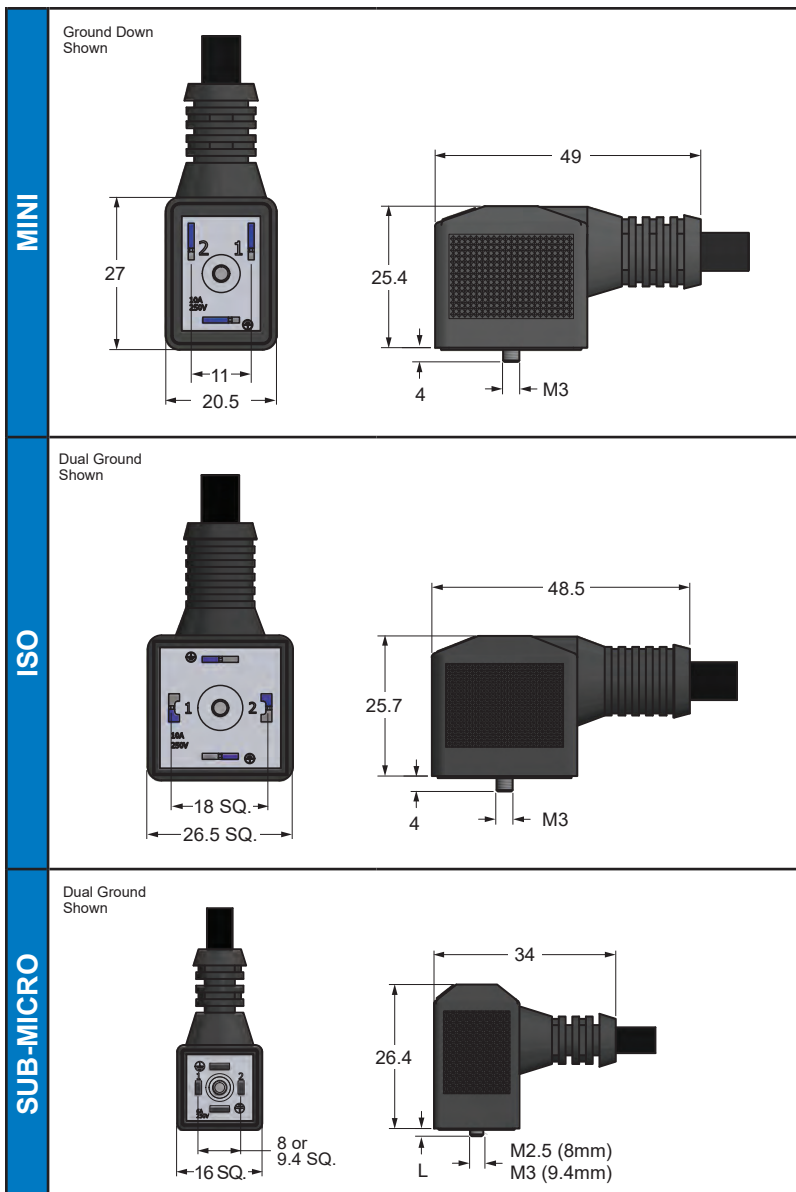

Technical Data

Current Max.	Continuous: 4 Amps Inrush: 10 Amps for 15 ms
Voltage Max.	120 V AC/DC 50/60 Hz
Voltage Drop	2.2 Volts Max.
Materials	Enclosure: Polyurethane (Black or Translucent) Gasket: Polyurethane
Temperature Range	-25° to +80°C
Environmental Protection	IP 67 AND NEMA 6, Dust tight and water resistant
Cable Type	Pressure extruded PVC jacket or PUR with & without shield (Others available on request)
Size	ISO: 18mm pin spacing - DIN Style "A" EN175301-803 MINI: 11mm pin spacing - Industry Standard Sub-Micro: 8mm pin spacing - DIN Style "C" EN 175301-803 Sub-Micro: 9.4mm pin spacing - Industry Standard
Number of Contacts	2+ ground

Wiring Information

TERMINAL CONFIGURATION		
Wire Type	EUR	US / HU
⊖ Chassis Ground	YEL & GRN	GRN
(+) Pos. / Hot Pin 1	BRN	BLK
(-) Neg. / Neut. Pin 2	BLU	WHT
Signal Pin 3	BLK	RED

NOTE: Slight discoloration may occur to translucent material after prolonged exposure to UV rays.

NOTE: When using MAC Valves with MINI and 9.4mm Sub-Micro, consult our factory.

Circuit Types

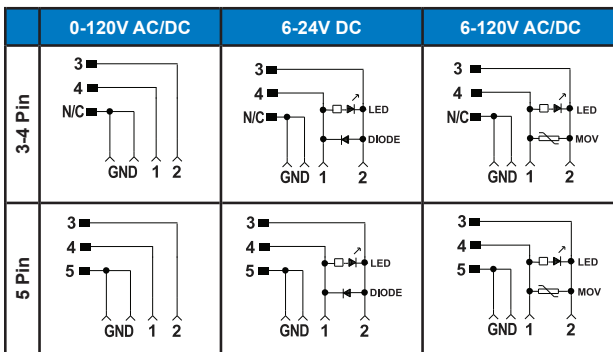

Pin Configuration



3 Pin 8mm
Male Input
A-Coding



4 Pin 8mm
Male Input
A-Coding



12mm
Male Input
A-Coding

Ordering Guide

All connectors come standard with integrated gasket and screw.

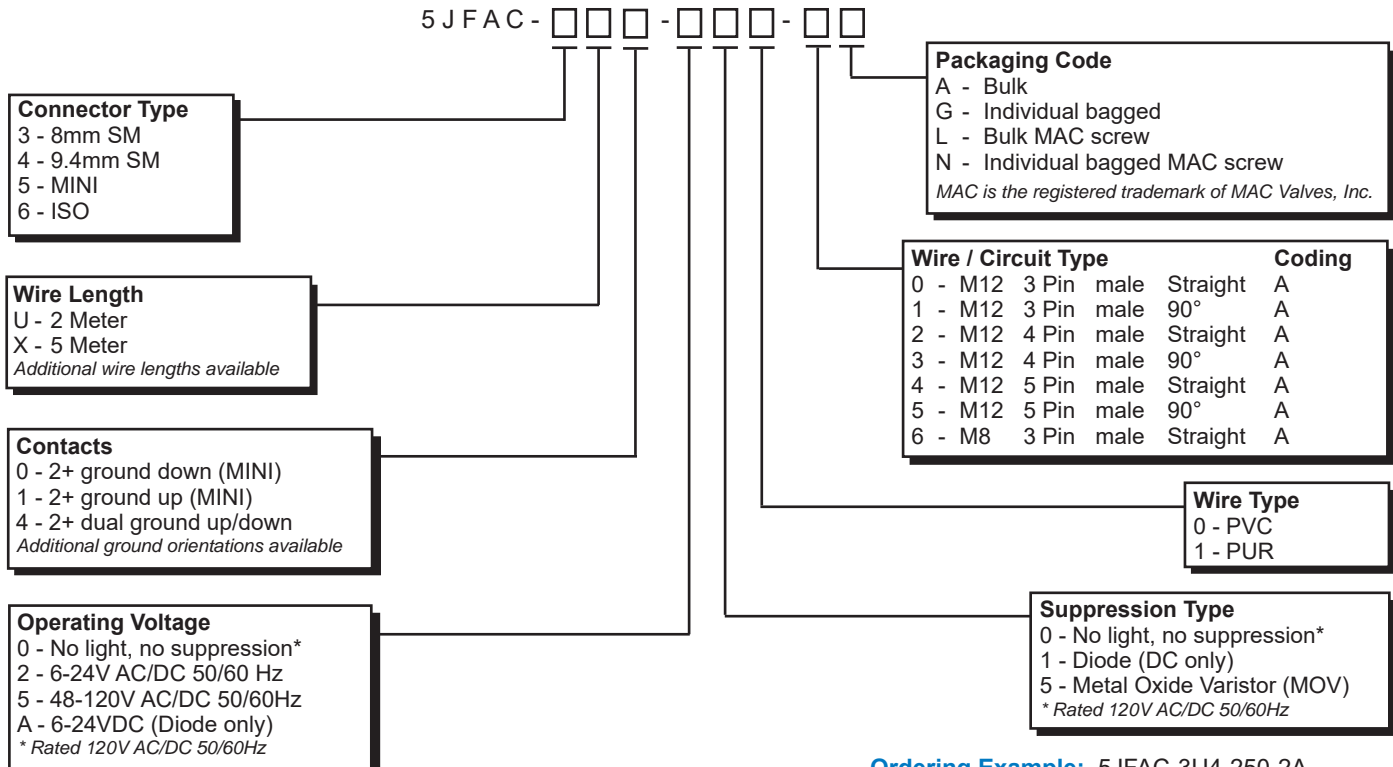

Ordering Example: 5JFAC-3U4-250-2A

8mm SM, 2 meter wire length, 2+ dual ground up/down, 6-24V AC/DC 50/60 Hz, lighted, MOV, PVC wire type, M12, 4 pin, male, Straight, Bulk

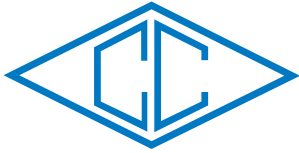

canfield connector
 8510 Foxwood Court
 Youngstown, Ohio 44514
 P:(330) 758-8299 F:(330) 758-8912
 www.canfieldconnector.com

5FMSD SERIES



MOLDED SOLENOID VALVE CONNECTORS WITH IN-LINE MICRO SOLENOID DRIVER POWER CONVERTER

General Description

The Canfield Connector 5FMSD Series is a solenoid driver circuit (Coil Saver) tucked away in our in-line electronics package coupled with our 5F all-molded DIN solenoid valve connector/gasket/cord assembly for ISO DIN Style "A" EN175301-803 (Formerly DIN 43650), MINI and 9.4mm (Industry Standard) and 8mm Sub-Micro (DIN 43650 "C") connectors. The integrated gasket design boasts an IP67/NEMA 6 rating and makes it impossible to lose the gasket. The Coil Saver enhances solenoid valve function as it lowers the wattage of solenoid operators of solenoid valves as it first applies a full voltage to ensure strong pull-in then drops the current when the solenoid magnetic circuit is most efficient and lowers wattage during long term energization or repeated cycles and lower RMS wattage. The fully encapsulated enclosure design allows for the Coil Saver to be isolated from the heat of the solenoid as well as installed upstream, away from the coil connector that is designed for this heat. The in-line package can control input DC voltage and supplies PWM VDC to the coil. The low profile "straight-line" interface/cord configuration allows for installation in many limited space applications and is proudly made in the U.S.A.

Dimensional Data

ALL DIMENSIONS ARE IN MILLIMETERS UNLESS OTHERWISE NOTED



ISO, Unlighted version shown above

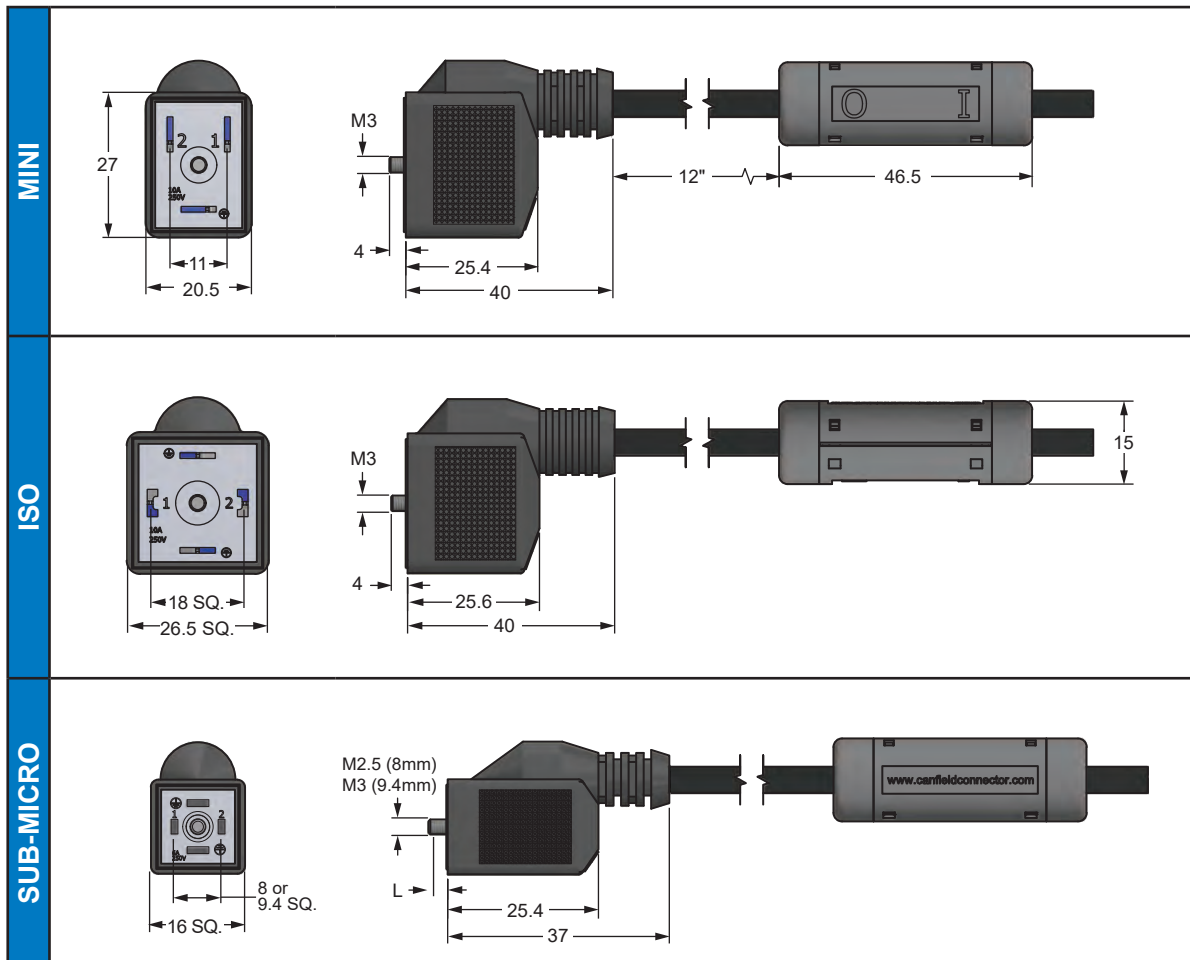

Technical Data

Output Current	Inrush: 8 Amps for 50 ms Holding: 1 Amp
Output Voltage Range	10% - 70% DC of Input
Input Voltage	12-24 VDC
Allowable Input Voltage DC Ripple	20% peak to peak
Input Voltage Tolerance	10%
Materials	Enclosure: Polyurethane Module: PA and Polyurethane
Temperature Range	-20° to +80°C
Environmental Protection	IP 67 AND NEMA 6, Dust tight and water resistant
Cable Diameter	0.190
Cable Conductor Colors	EU Code: Blue, brown, yellow/green US Code: Black, green, white (Others available on request)
Cable Type	Pressure extruded PVC jacket (Others available on request)
Wire Gauge	20 AWG standard
Size	ISO: 18mm pin spacing - DIN Style "A" EN175301-803 MINI: 11mm pin spacing - Industry Standard Sub-Micro: 8mm pin spacing - DIN Style "C" EN 175301-803 Sub-Micro: 9.4mm pin spacing - Industry Standard
Number of Contacts	2+ ground

NOTE: Slight discoloration may occur to translucent material after prolonged exposure to UV rays.
NOTE: When using MAC Valves with MINI and 9.4mm Sub-Micro, consult our factory.

Wiring Information

TERMINAL CONFIGURATION		
Wire Type	EUR	US
⊖ Chassis Ground	YEL & GRN	GRN
(+) Pos. / Hot Pin 1	BRN	BLK
(-) Neg. / Neut. Pin 2	BLU	WHT

Ordering Information

All connectors come standard with integrated gasket and screw.

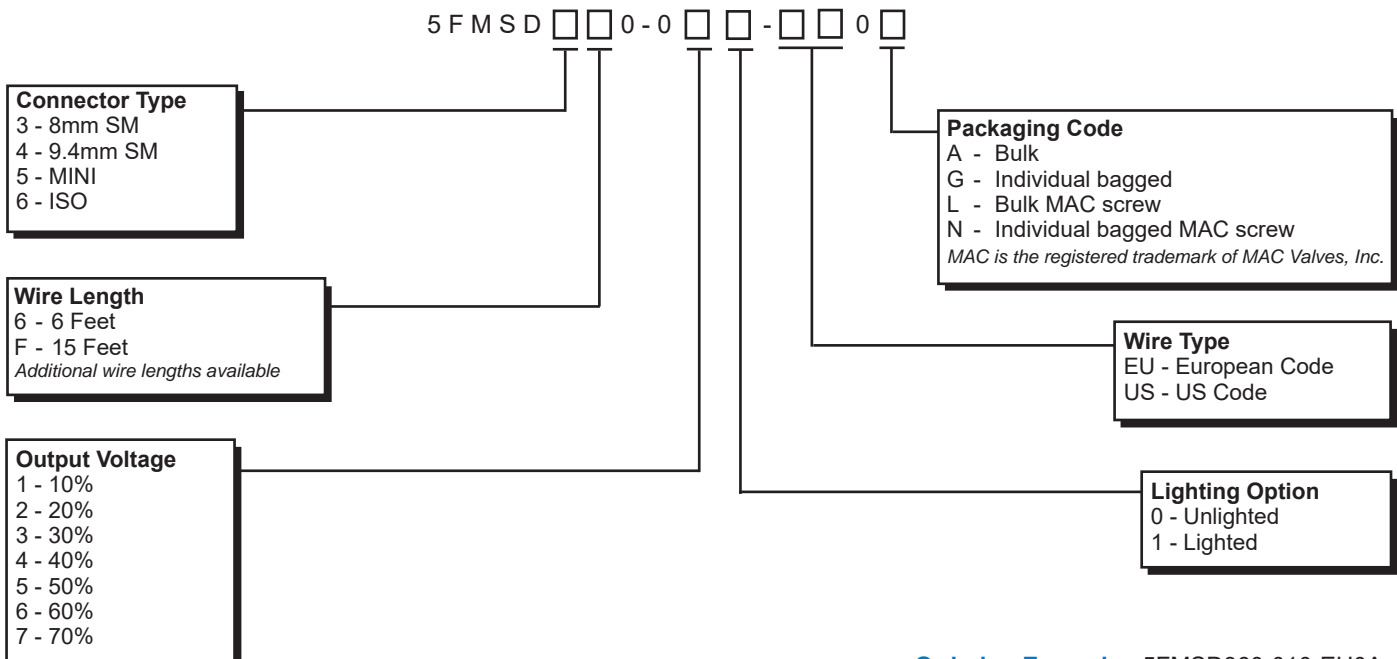

Ordering Example: 5FM3D360-010-EU0A

8mm SM, 6 Ft., 10% output voltage,
Unlighted, European wire type, Bulk

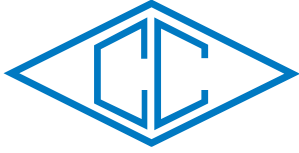

canfield connector
 8510 Foxwood Court
 Youngstown, Ohio 44514
 P:(330) 758-8299 F:(330) 758-8912
 www.canfieldconnector.com

5JMSD SERIES **Coil Saver®**

**MOLDED SOLENOID VALVE CONNECTORS
 WITH IN-LINE MICRO SOLENOID
 DRIVER POWER CONVERTER**

General Description

The Canfield Connector 5JMSD Series is a solenoid driver circuit (Coil Saver) tucked away in our in-line electronics package coupled with our 5J all-molded DIN solenoid valve connector/gasket/cord assembly for ISO DIN Style "A" EN175301-803 (Formerly DIN 43650), MINI and 9.4mm (Industry Standard) and 8mm Sub-Micro (DIN 43650 "C") connectors. The integrated gasket design boasts an IP67/NEMA 6 rating and makes it impossible to lose the gasket. The Coil Saver enhances solenoid valve function as it lowers the wattage of solenoid operators of solenoid valves as it first applies a full voltage to ensure strong pull-in then drops the current when the solenoid magnetic circuit is most efficient and lowers wattage during long term energization or repeated cycles and lower RMS wattage. The fully encapsulated enclosure design allows for the Coil Saver to be isolated from the heat of the solenoid as well as installed upstream, away from the coil connector that is designed for this heat. The in-line package can control input DC voltage and supplies PWM VDC to the coil. The 5JMSD Series is proudly made in the U.S.A.

Dimensional Data

ALL DIMENSIONS ARE IN MILLIMETERS UNLESS OTHERWISE NOTED



ISO, Unlighted version shown above

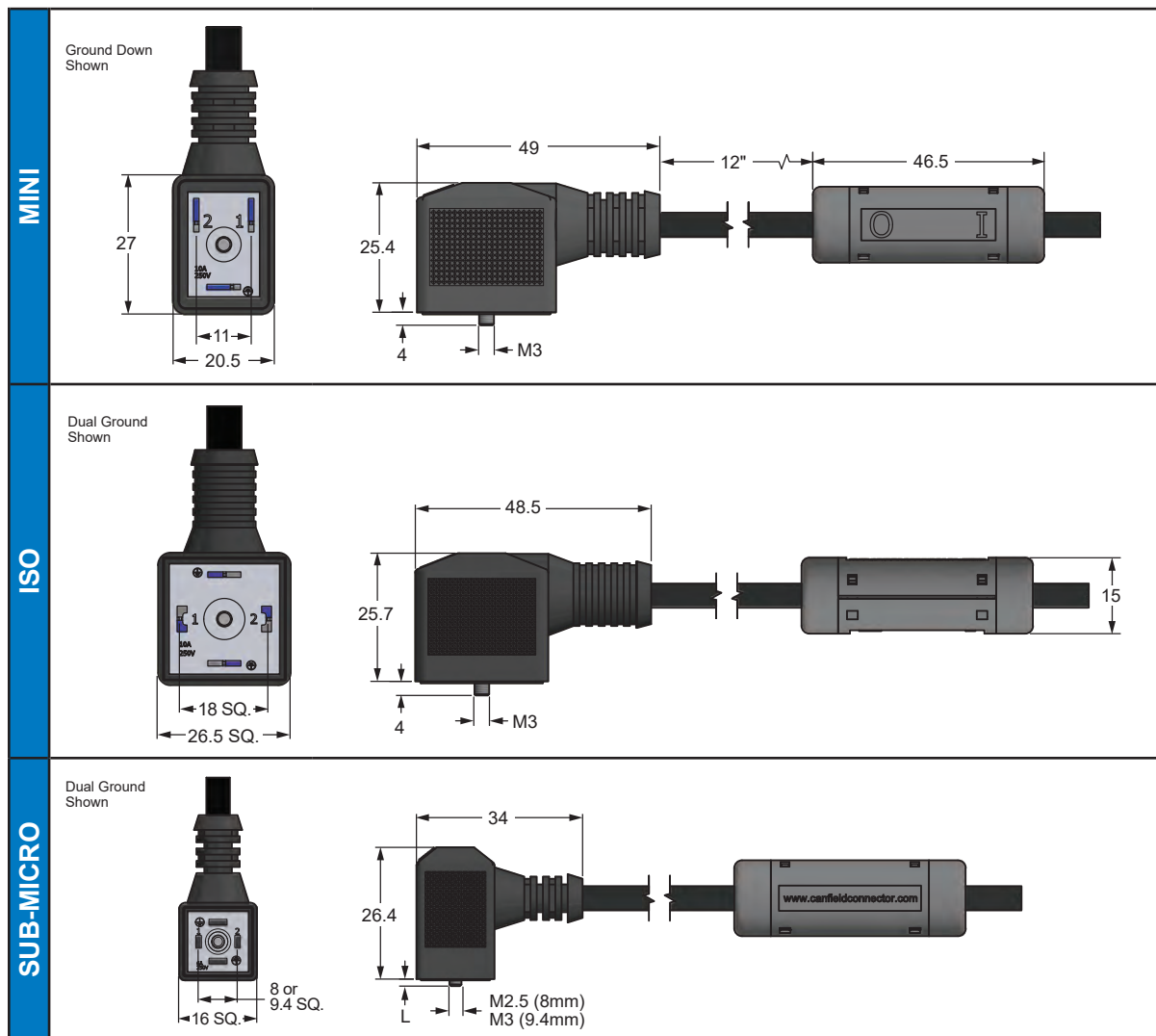

Technical Data

Output Current	Inrush: 8 Amps for 50 ms Holding: 1 Amp
Output Voltage Range	10% - 70% DC of Input
Input Voltage	12-24 VDC
Allowable Input Voltage DC Ripple	20% peak to peak
Input Voltage Tolerance	10%
Materials	Enclosure: Polyurethane Module: PA and Polyurethane
Temperature Range	-20° to +80°C
Environmental Protection	IP 67 AND NEMA 6, Dust tight and water resistant
Cable Diameter	0.190
Cable Conductor Colors	EU Code: Blue, brown, yellow/green US Code: Black, green, white (Others available on request)
Cable Type	Pressure extruded PVC jacket (Others available on request)
Wire Gauge	20 AWG standard
Size	ISO: 18mm pin spacing - DIN Style "A" EN175301-803 MINI: 11mm pin spacing - Industry Standard Sub-Micro: 8mm pin spacing - DIN Style "C" EN 175301-803 Sub-Micro: 9.4mm pin spacing - Industry Standard
Number of Contacts	2+ ground

Wiring Information

TERMINAL CONFIGURATION		
Wire Type	EUR	US
⊖ Chassis Ground	YEL & GRN	GRN
(+) Pos. / Hot Pin 1	BRN	BLK
(-) Neg. / Neut. Pin 2	BLU	WHT

NOTE: Slight discoloration may occur to translucent material after prolonged exposure to UV rays.
NOTE: When using MAC Valves with MINI and 9.4mm Sub-Micro, consult our factory.

Ordering Information

All connectors come standard with integrated gasket and screw.

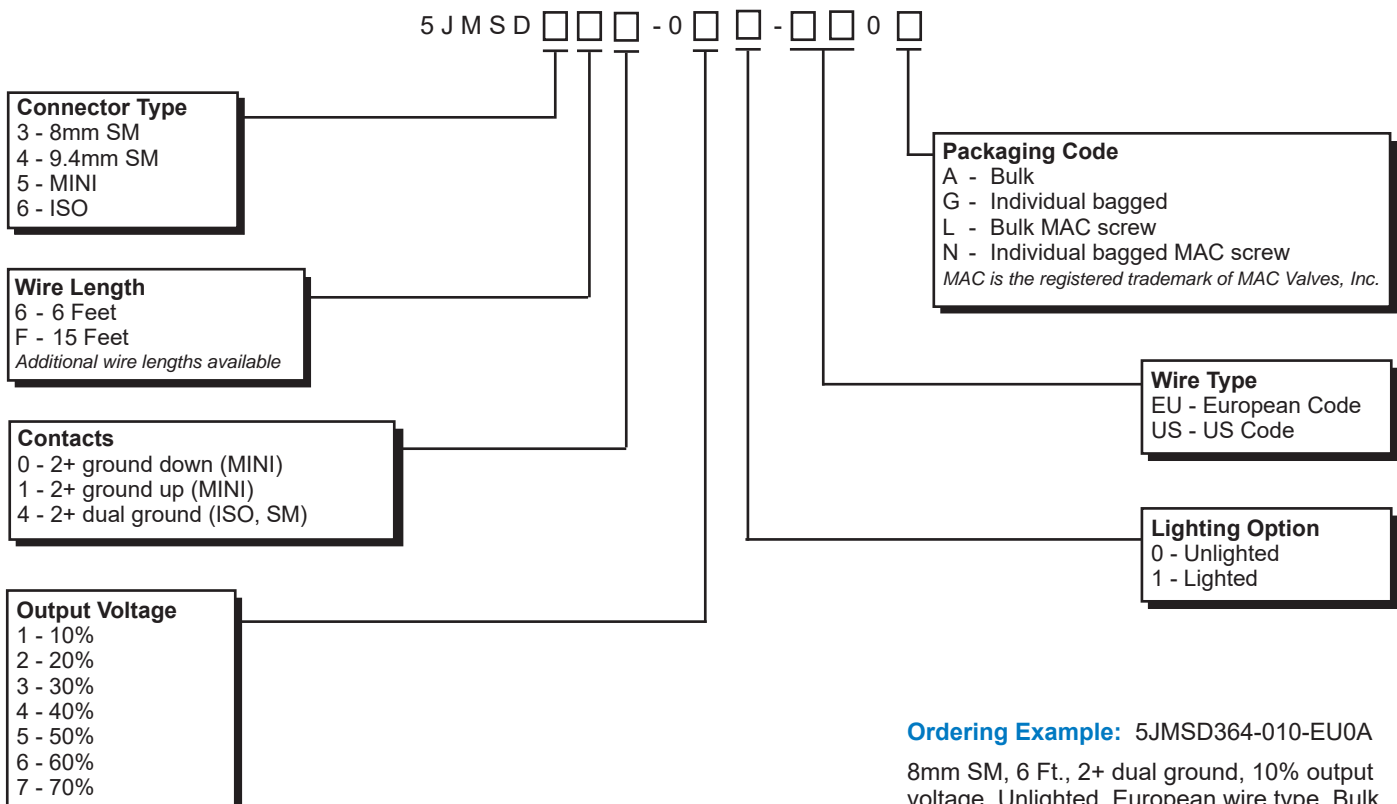

Ordering Example: 5JMSD364-010-EU0A

8mm SM, 6 Ft., 2+ dual ground, 10% output voltage, Unlighted, European wire type, Bulk

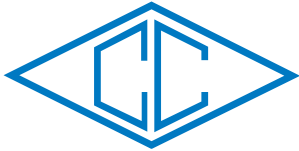

canfield connector
 8510 Foxwood Court
 Youngstown, Ohio 44514
 P:(330) 758-8299 F:(330) 758-8912
 www.canfieldconnector.com

5FR SERIES

RECTIFIED MOLDED SOLENOID VALVE CONNECTORS

General Description

The Canfield 5FR Series solenoid valve connectors incorporate a full-wave bridge rectifier inside a fully molded connector. The 5FR converts alternating current to direct current reducing coil burnout due to valve sticking. Also, direct current eliminates AC "hum" inherent to alternating current. Made from rugged yet flexible polyurethane, the connector housing boasts high durability factors and application versatility. The low profile "straight-line" interface/cord configuration allows for installation in many limited space applications. The integrated gasket design boasts an IP67/NEMA 6 rating and makes it impossible to lose the gasket! Features bi-directional indicator lights, and load suppression (not intended for UL 1449). The 5FR Series is proudly made in the U.S.A.

Dimensional Data

ALL DIMENSIONS ARE IN MILLIMETERS UNLESS OTHERWISE NOTED



ISO, Unlighted version shown above

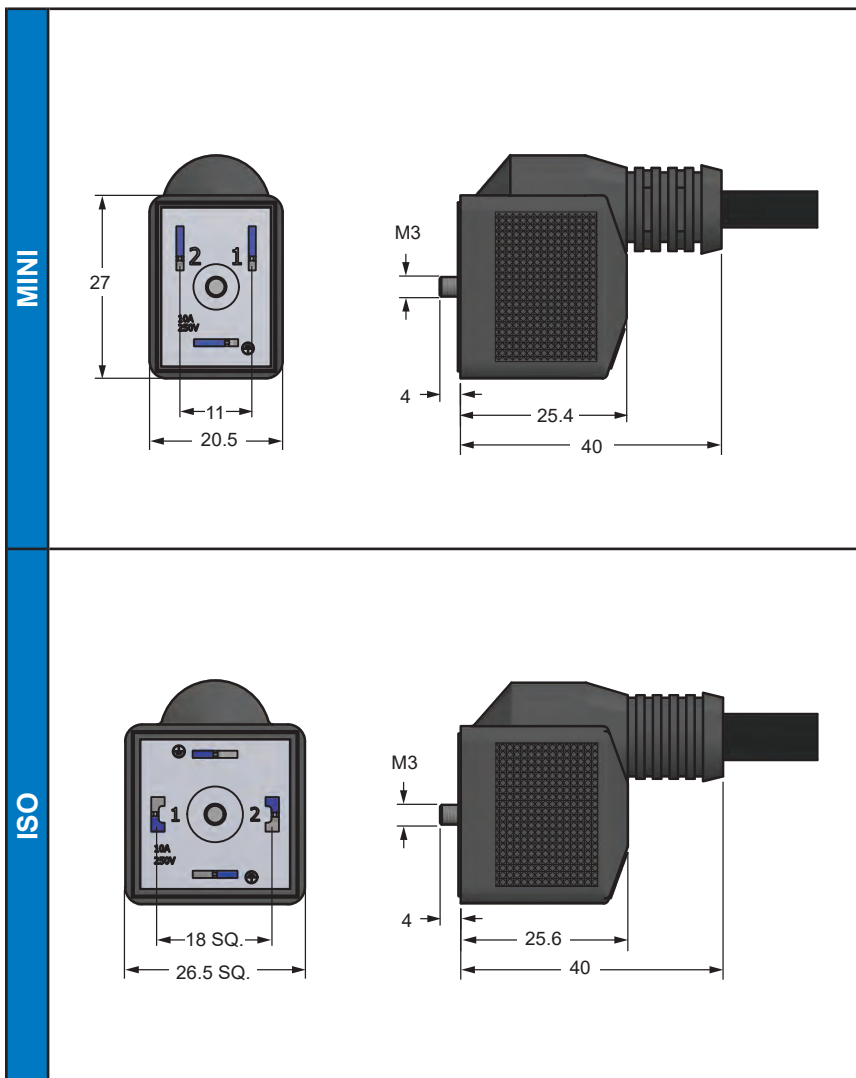

Consult factory for available versions recognized under the Component Program of Underwriters Laboratories, Inc.



Consult factory for available versions listed by Canadian Standards Association for use with certified electrical equipment.

Technical Data

Current Max.	Continuous: 1 Amps Inrush: 15 Amps for 15 ms
Voltage Max.	250 VAC 50/60 Hz
Voltage Drop	2.2 Volts Max.
Materials	Enclosure: Polyurethane Gasket: Polyurethane
Temperature Range	-25° to +80°C
Environmental Protection	IP 67 AND NEMA 6, Dust tight and water resistant
Cable Diameter	ISO / MINI: EU (European) / US (U.S.A.): 0.275 ISO / MINI: HU (Hard Usage): .300
Cable Conductor Colors	EU Code: Blue, brown, yellow/green US Code: Black, green, white (Others available on request)
Cable Type	Pressure extruded PVC jacket Hard usage cordage "S" type with SJTOW standard PVC jacket (Others available on request)
Wire Gauge	18 AWG standard
Size	ISO: 18mm pin spacing - DIN Style "A" EN175301-803 MINI: 11mm pin spacing - Industry Standard
Number of Contacts	2+ ground

NOTE: Slight discoloration may occur to translucent material after prolonged exposure to UV rays.

Wiring Information

TERMINAL CONFIGURATION		
Wire Type	EUR	US / HU
⊕ Chassis Ground	YEL & GRN	GRN
(+) Pos. / Hot Pin 1	BRN	BLK
(-) Neg. / Neut. Pin 2	BLU	WHT

Schematic

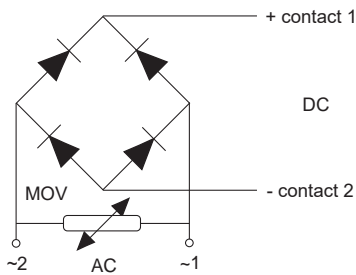

Ordering Information

All connectors come standard with integrated gasket and screw.

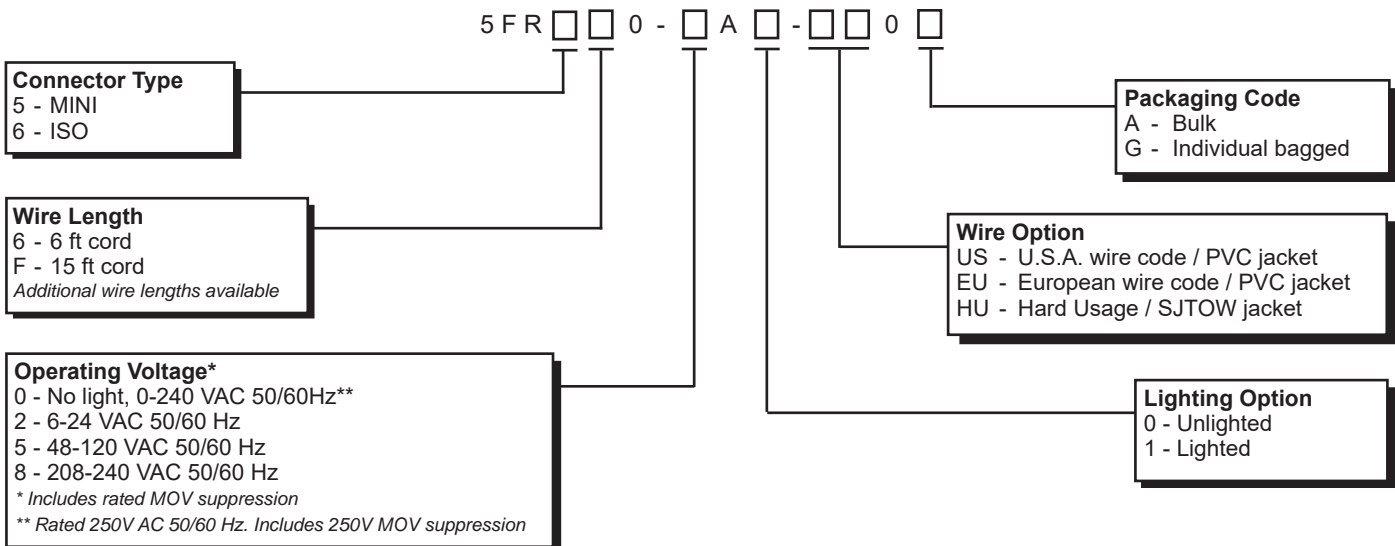

Ordering Example: 5FR660-2A1-US0A

ISO, 6 ft wire length, 6-24 VAC 50/60 Hz, Lighted, U.S.A. wire code / PVC jacket, Bulk

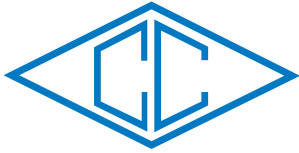

canfield connector
 8510 Foxwood Court
 Youngstown, Ohio 44514
 P:(330) 758-8299 F:(330) 758-8912
 www.canfieldconnector.com

5JR SERIES

RECTIFIED MOLDED SOLENOID VALVE CONNECTORS

General Description

The Canfield 5JR Series solenoid valve connectors incorporate a full-wave bridge rectifier inside a fully molded connector. The 5JR converts alternating current to direct current reducing coil burnout due to valve sticking. Also, direct current eliminates AC "hum" inherent to alternating current. Made from rugged yet flexible polyurethane, the connector housing boasts high durability factors and application versatility. The low profile 90° interface/cord configuration allows for installation in many limited space applications. The integrated gasket design boasts an IP67/NEMA 6 rating and makes it impossible to lose the gasket! Features bi-directional indicator lights, and load suppression (not intended for UL 1449). The 5JR Series is proudly made in the U.S.A.

Dimensional Data

ALL DIMENSIONS ARE IN MILLIMETERS UNLESS OTHERWISE NOTED



ISO, Lighted version shown above

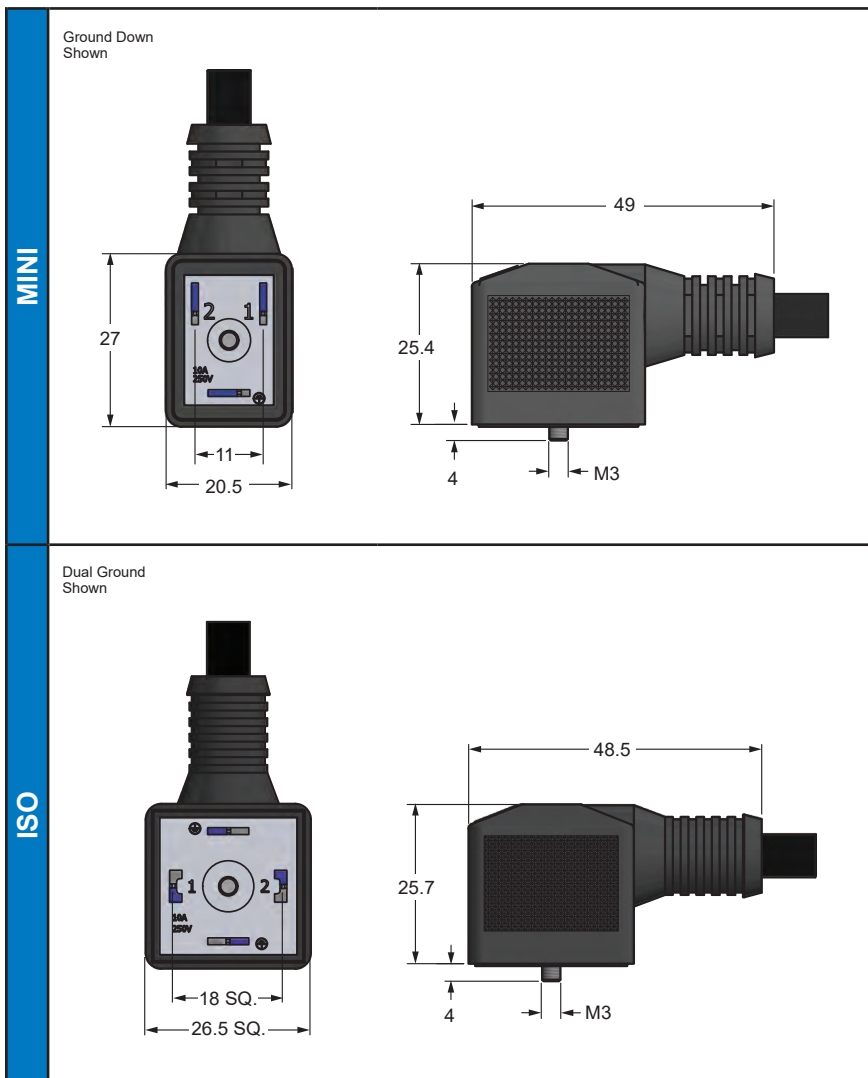

Consult factory for available versions recognized under the Component Program of Underwriters Laboratories, Inc.



Consult factory for available versions listed by Canadian Standards Association for use with certified electrical equipment.

Technical Data

Current Max.	Continuous: 1 Amps Inrush: 15 Amps for 15 ms
Voltage Max.	250 VAC 50/60 Hz
Voltage Drop	2.2 Volts Max.
Materials	Enclosure: Polyurethane Gasket: Polyurethane
Temperature Range	-25° to +80°C
Environmental Protection	IP 67 AND NEMA 6, Dust tight and water resistant
Cable Diameter	ISO / MINI: EU (European) / US (U.S.A.): 0.275 ISO / MINI: HU (Hard Usage): .300
Cable Conductor Colors	EU Code: Blue, brown, yellow/green US Code: Black, green, white (Others available on request)
Cable Type	Pressure extruded PVC jacket Hard usage cordage "S" type with SJTOW standard PVC jacket (Others available on request)
Wire Gauge	18 AWG standard
Size	ISO: 18mm pin spacing - DIN Style "A" EN175301-803 MINI: 11mm pin spacing - Industry Standard
Number of Contacts	2+ ground

NOTE: Slight discoloration may occur to translucent material after prolonged exposure to UV rays.

Wiring Information

TERMINAL CONFIGURATION		
Wire Type	EUR	US / HU
⊕ Chassis Ground	YEL & GRN	GRN
(+) Pos. / Hot Pin 1	BRN	BLK
(-) Neg. / Neut. Pin 2	BLU	WHT

Schematic

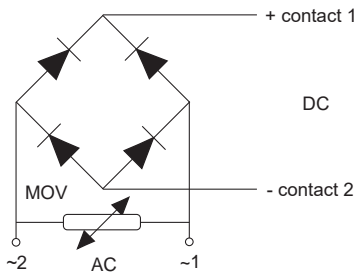

Ordering Information

All connectors come standard with integrated gasket and screw.

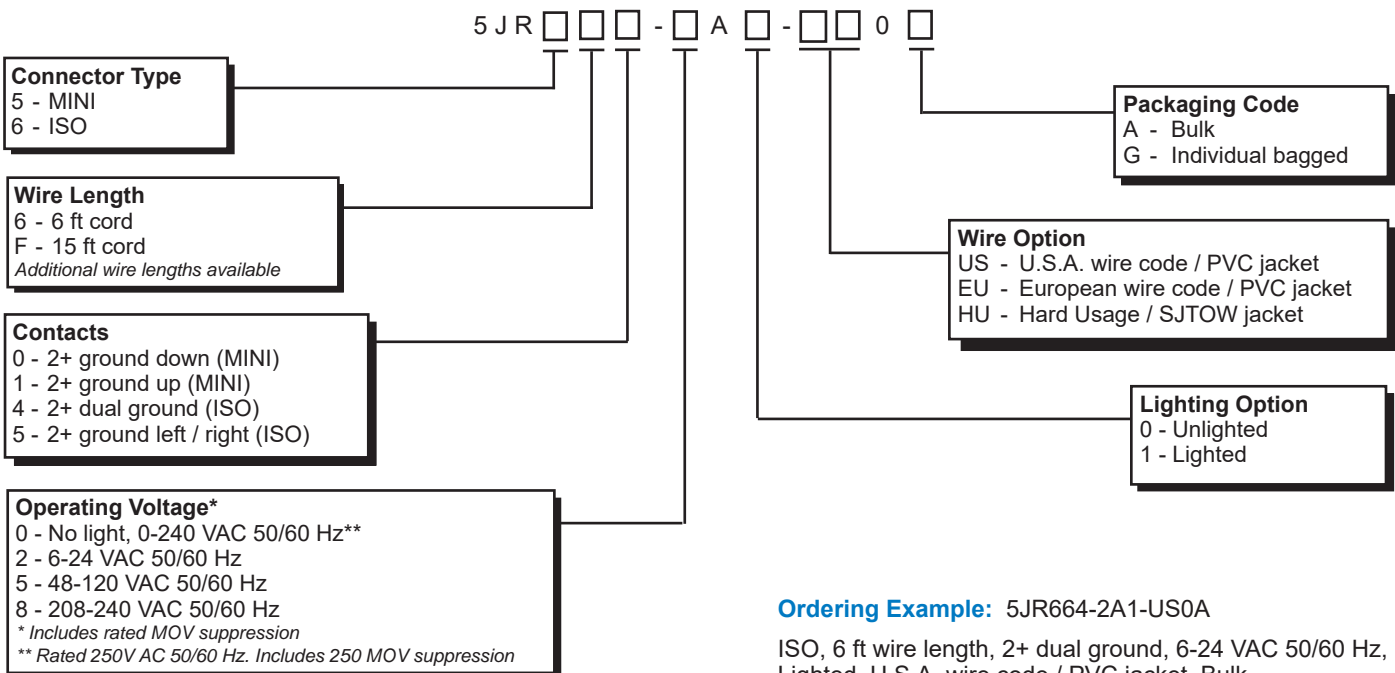

Ordering Example: 5JR664-2A1-US0A

ISO, 6 ft wire length, 2+ dual ground, 6-24 VAC 50/60 Hz, Lighted, U.S.A. wire code / PVC jacket, Bulk

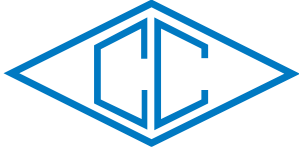

canfield connector
 8510 Foxwood Court
 Youngstown, Ohio 44514
 P:(330) 758-8299 F:(330) 758-8912
 www.canfieldconnector.com

5JGT SERIES



**DIN TO GT
 ADAPTER**

General Description

The GatorMate™ brand of electrical connectors from Canfield Connector are as tough as their name. This innovative rugged 5JGT connector marries our popular fully molded 5J connector to the Deutsch style GT 2 Pin Receptacle connector, exceeding expectation. The over-molded 5JGT mobile hydraulic DIN Style "A" EN175301-803 (Formerly DIN 43650) to GT DT04-2P Adapter/connector solution is designed for use with hydraulic valves to facilitate connection to the DT06 mating connector. The connector is available with indicator lights and surge suppression and unlighted black or grey housing for "A" and "B" solenoids. All standard voltages are available and the housing is IP67 environment rated. The product is designed to adapt DIN 43650 Form "A" solenoid coils to the GT connector found in many mobile hydraulic solenoid valve applications. Proudly made in the U.S.A.

Dimensional Data

ALL DIMENSIONS ARE IN MILLIMETERS UNLESS OTHERWISE NOTED

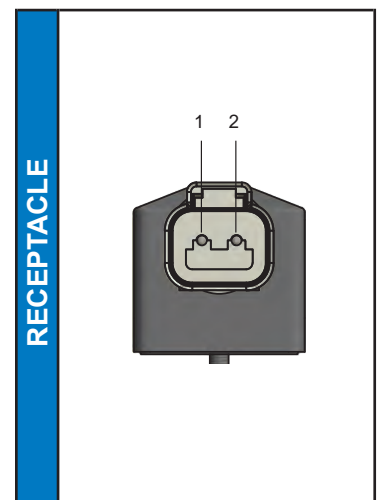
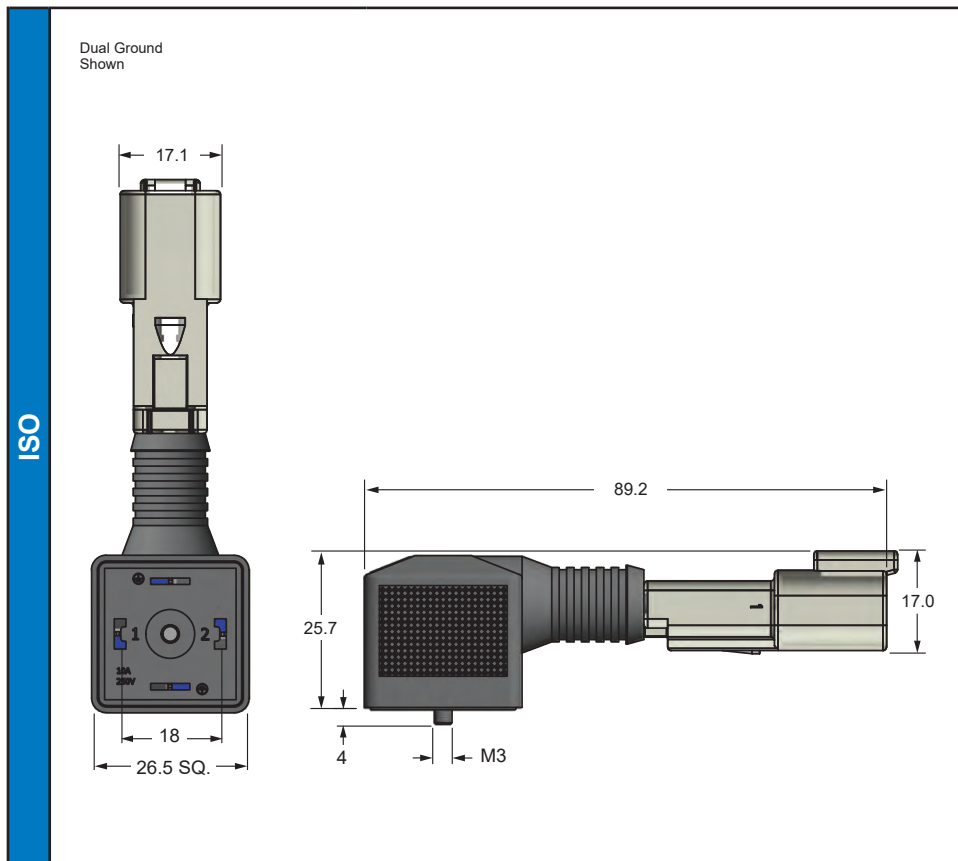
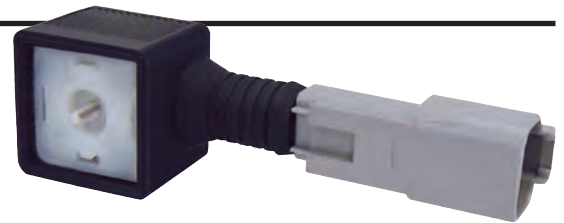

Technical Data

Current Max.	10 AMPS
Voltage Max.	250 VAC 50/60 Hz, 300 VDC
Materials	DIN Form A: TPU DT04: Thermoplastic, silicone seal
Temperature Range	-25° to +80°C
Environmental Protection	IP 67 AND NEMA 6
Size	ISO: 18mm pin spacing - DIN Style "A" EN175301-803
Number of Contacts	2 connections

NOTE: Slight discoloration may occur to translucent material after prolonged exposure to UV rays.

Schematic

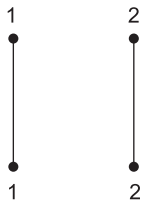

Ordering Information

All connectors come standard with integrated gasket and screw.

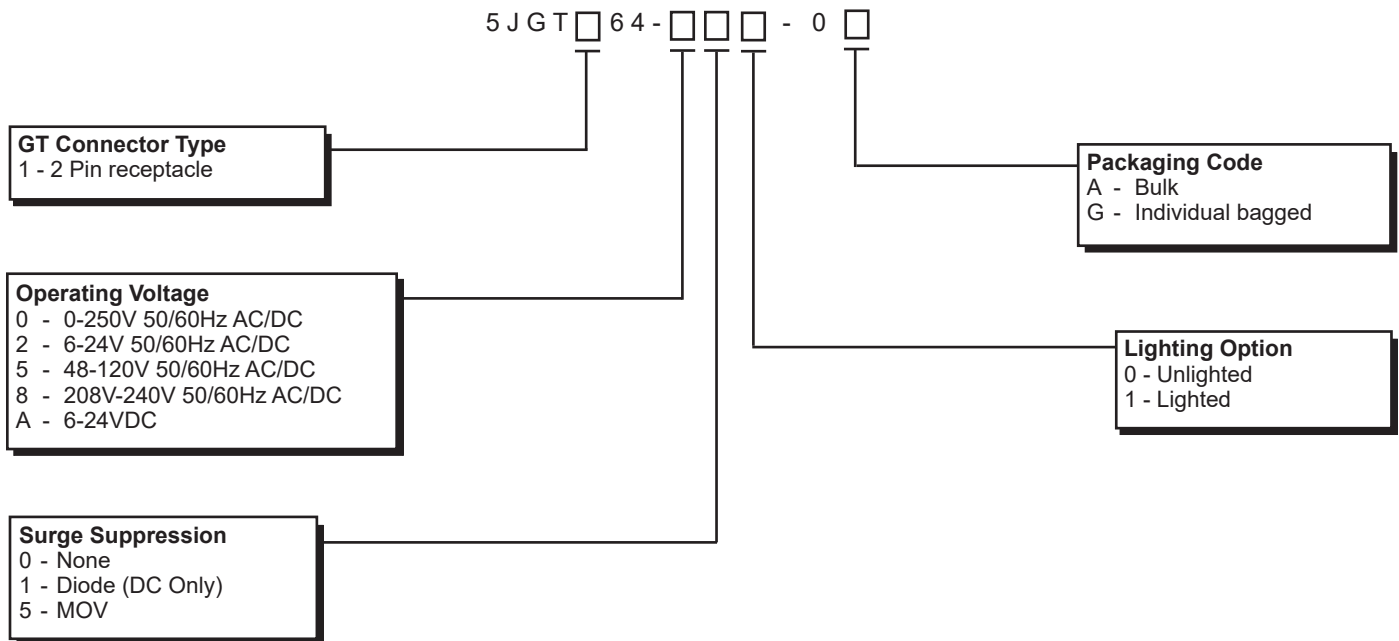

Ordering Example: 5JGT164-000-0A

2 Pin receptacle, 0-250V 50/60Hz AC/DC,
No Suppression, Bulk

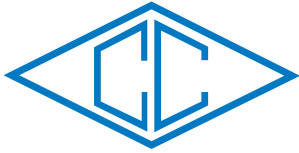

canfield connector
 8510 Foxwood Court
 Youngstown, Ohio 44514
 P:(330) 758-8299 F:(330) 758-8912
 www.canfieldconnector.com

GT SERIES



MOLDED RECEPTACLE AND PLUG CONNECTORS

General Description

The GatorMate™ GT Series molded Receptacle and Plug mobile connectors by Canfield Connector have all the positive attributes of the basic Deutsch style but enhance the wired section of the connectors accommodating a molded-jacketed cable with added features of indicator lights. These rugged connectors feature an IP67 rating and are shock, vibration, moisture and dust resistant. The compact robust design allows the user the ability to see power applied and holds transient voltage/current within the connector. The GT Series is available with many wire styles and lengths and boasts high durability factors and application versatility and is available in either the Receptacle or Plug style versions. Cables available are the well-known Canfield Connector flooded jacketed cable. Canfield Connector offers any version of the GT Series connector with special wires including high flex, media compatible wire, special use wire, or high temperature wire on request and is proudly made in the U.S.A.

Dimensional Data

ALL DIMENSIONS ARE IN MILLIMETERS UNLESS OTHERWISE NOTED

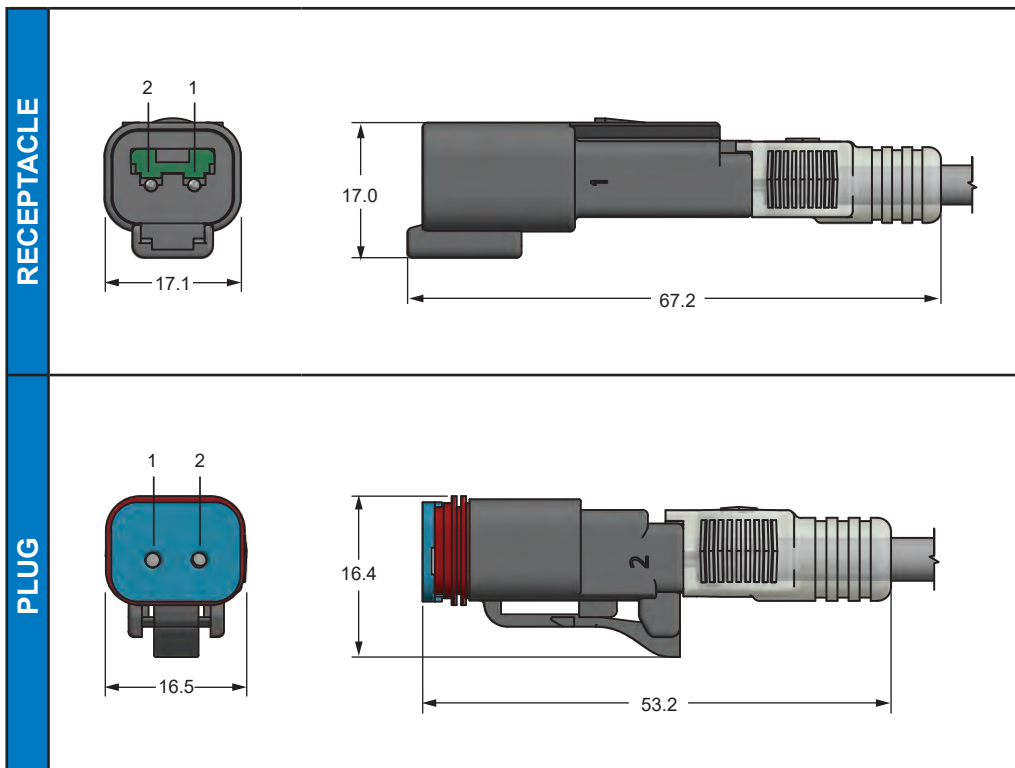
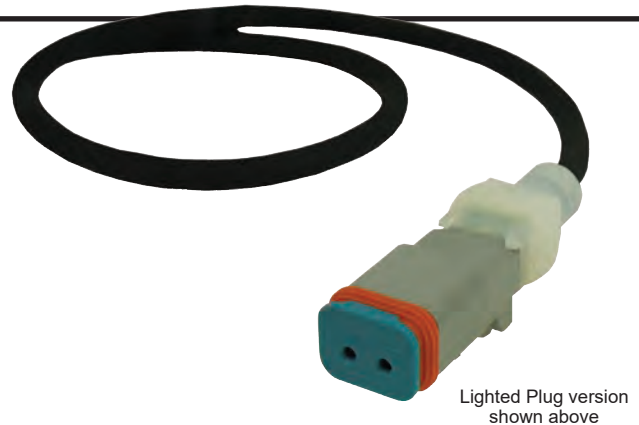
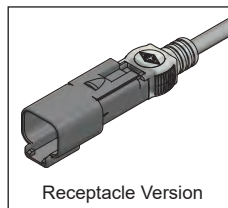

Technical Data

Current Max.	10 Amps
Voltage Max.	250 VAC 50/60 Hz, 300 VDC
Voltage Drop	2.2 Volts Max.
Materials	Housing: Thermoplastic Contacts: Brass, Nickel Plating Overmold: TPU
Temperature Range	PVC: -25° to +80°C TPU: -40° to +80°C
Environmental Protection	IP67
Cable Diameter	0.190
Cable Conductor Colors	Brown / Blue (Others available on request)
Cable Type	PVC or PUR; Black
Wire Gauge	18 AWG
Number of Contacts	2 connections

NOTE: Slight discoloration may occur to translucent material after prolonged exposure to UV rays.

Wiring Information

TERMINAL CONFIGURATION	
Wire Type	EUR
(+) Pos. / Hot Pin 1	BRN
(-) Neg. / Neut. Pin 2	BLU

Ordering Information

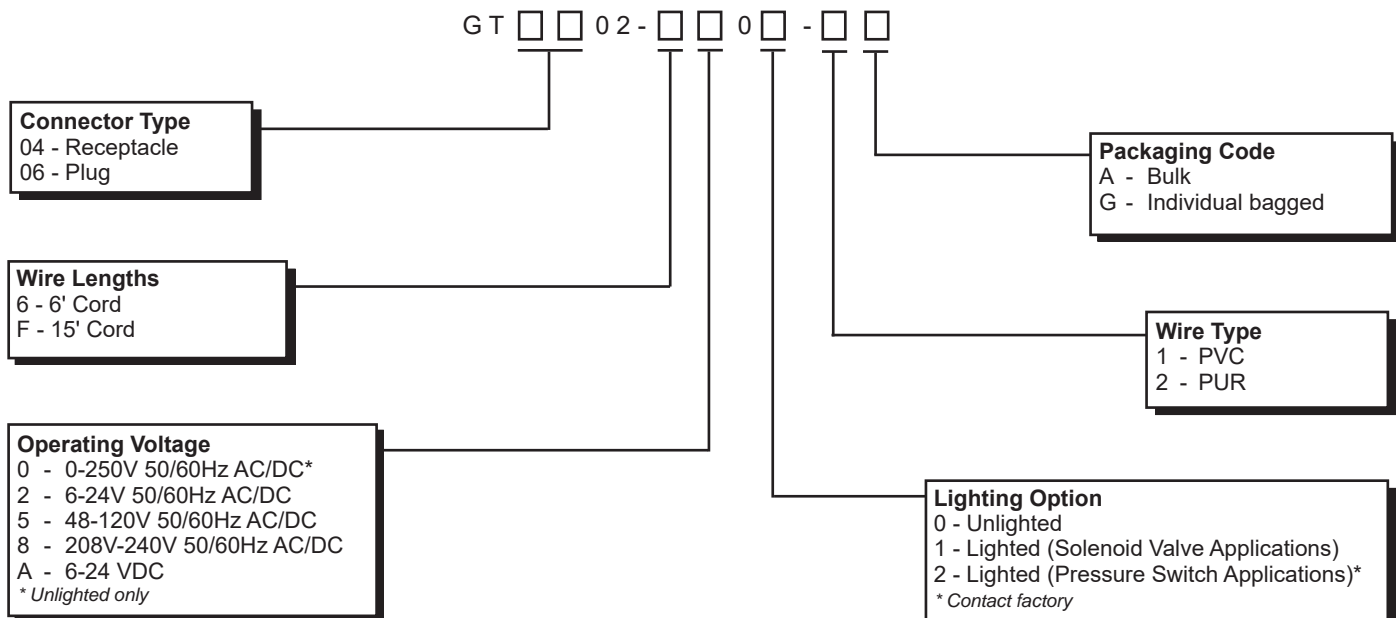

Ordering Example: GT0602-6201-1A

Plug Type, 6' Cord Length, 6-24V 50/60Hz AC/DC, Lighted, PVC, Bulk

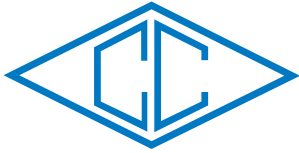

canfield connector
 8510 Foxwood Court
 Youngstown, Ohio 44514
 P:(330) 758-8299 F:(330) 758-8912
 www.canfieldconnector.com

MCCR SERIES

MULTIPLE CONTROL CONNECTOR

General Description

The Canfield Connector MCCR is a patented unique cable distribution connector which uses pass-through technology to allow a single connector for control of multiple parallel or independent devices that use the DIN Style "A" EN175301-803 (Formerly DIN 43650) interface. The key feature is that this product saves at least one wire run from the control to the solenoid valve including associated hardware and processes. Devised with double solenoids and solenoid valve manifolds in mind, the MCCR allows for simplified wiring and easy replacement of components in an automated, modular environment. IP 65 environmental protection remains as the gasket-thin head fits between a single input female connector and the associated male device. Exiting from the MCCR head is a three-conductor cable with the 5K female connector attached. Two available circuits allow for separate (independent) or parallel (simultaneous) control of the downstream device(s) which can also be daisy-chained depending on current requirements.

Dimensional Data

ALL DIMENSIONS ARE IN MILLIMETERS UNLESS OTHERWISE NOTED



Patent # 6,846,198

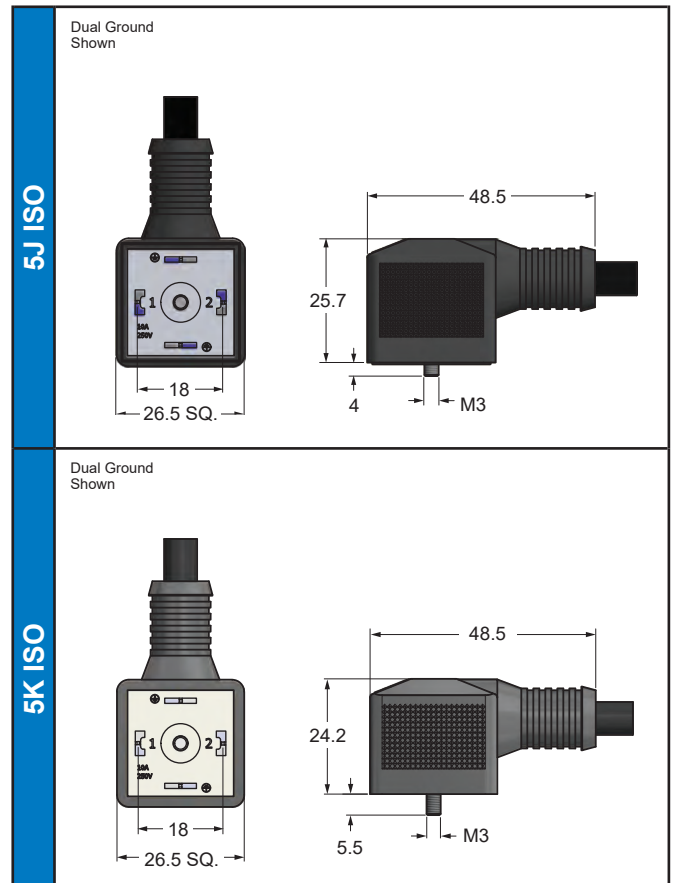
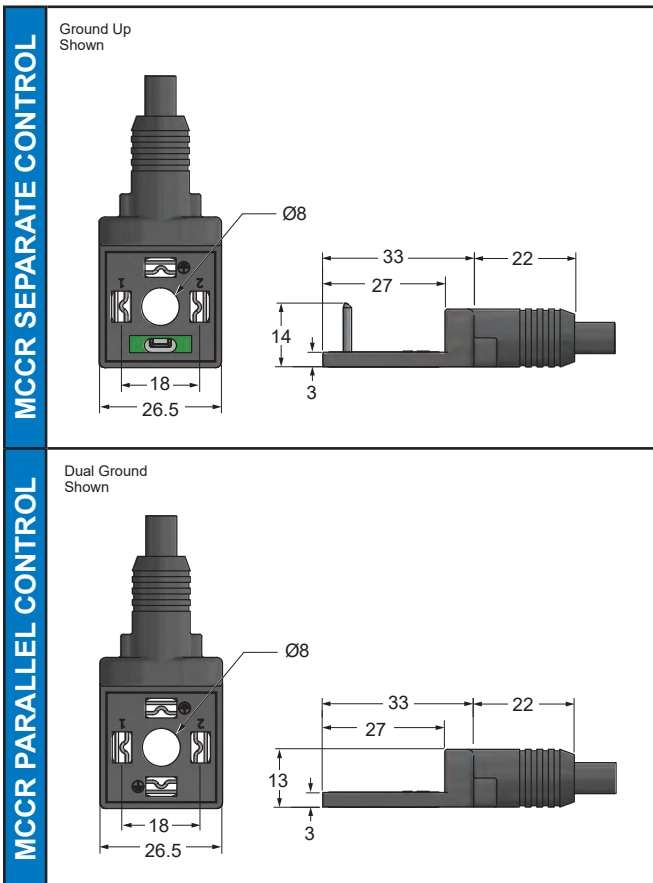

Technical Data

Current Max.	10 Amps
Voltage Max.	250 VAC 50/60 Hz, 300 VDC
Materials	Enclosure: Polyurethane Gasket: Nitrile
Temperature Range	-25° to +80°C
Environmental Protection	Connector: IP 67 and NEMA 6, Dust tight and water resistant (with gasket) MCCR Interface: IP65 and NEMA 4
Cable Diameter	0.275
Cable Conductor Colors	EU Code: Blue, brown, yellow/green (4th conductor version black)
Cable Type	Pressure extruded PVC jacket
Wire Gauge	18 AWG standard
Size	ISO: 18mm pin spacing - DIN Style "A" EN175301-803
Number of Contacts	2+ ground, 2+ dual ground,

Circuit Diagram / Applications

Separate Control
Circuit Type #1 and Circuit Type #2

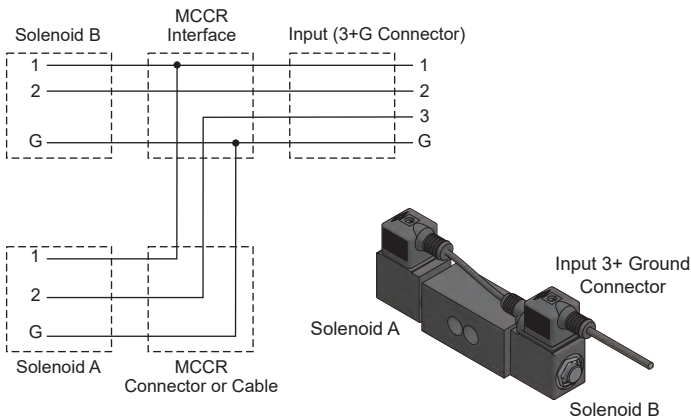

2+G Parallel Control / Simultaneous Solenoid Operation
Circuit Type #3

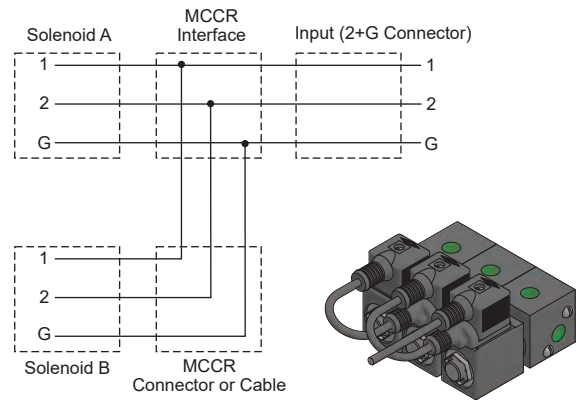

Ordering Information

Each connector kit contains screw, washer and gasket assembly.

MCCR - 1 - 10

<p>Wire Length*</p> <p>01 - 1 in. 02 - 2 in. 03 - 3 in. 04 - 4 in. 05 - 5 in. 06 - 6 in. 07 - 7 in. 08 - 8 in. 09 - 9 in. 10 - 10 in. 11 - 11 in. 12 - 12 in.</p>	<p>Circuit Type</p> <p>1 - Separate control ground down 2 - Separate control ground up 3 - Parallel control 2+dual ground</p>	<p>Connector Type</p> <p>0 - Cable (no connector) 3 - 5J ISO Molded connector (2+dual ground, Independent control) 4 - 5K ISO Molded connector (2+dual ground, Parallel control)</p> <p><i>For indicator lights and surge suppression, consult factory</i></p>
--	--	---

*For Wire Length, measure from Center Point to Center Point.

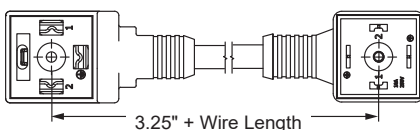

Ordering Example: MCCR-01113-10
1 in. Wire length, Separate control ground down, ISO Molded connector

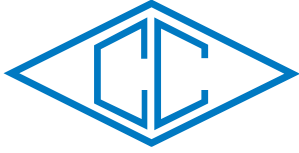

canfield connector
 8510 Foxwood Court
 Youngstown, Ohio 44514
 P:(330) 758-8299 F:(330) 758-8912
 www.canfieldconnector.com

Connectors and Accessories

5000 SERIES

FIELD WIREABLE MINI SOLENOID VALVE CONNECTOR

General Description

The Canfield Connector 5000 Series field wireable MINI solenoid valve connector is a high quality interconnection device for use with solenoid valves and pressure switches. The connector features a PG9 strain relief, 3/8" or 1/2" conduit wire pass through, all with screw terminals for wire connections. The MINI accommodates wire from .240" to .410" diameter as a standard with an AWG of 14 maximum. Environment resistance of NEMA 4 / IP 65 along with versions which are CSA approved ensure long trouble free service. Current maximum of 10 Amps and the temperature rating of -40° to +125°C encompasses most applications. The interface is an industry standard.

Dimensional Data

ALL DIMENSIONS ARE IN MILLIMETERS UNLESS OTHERWISE NOTED

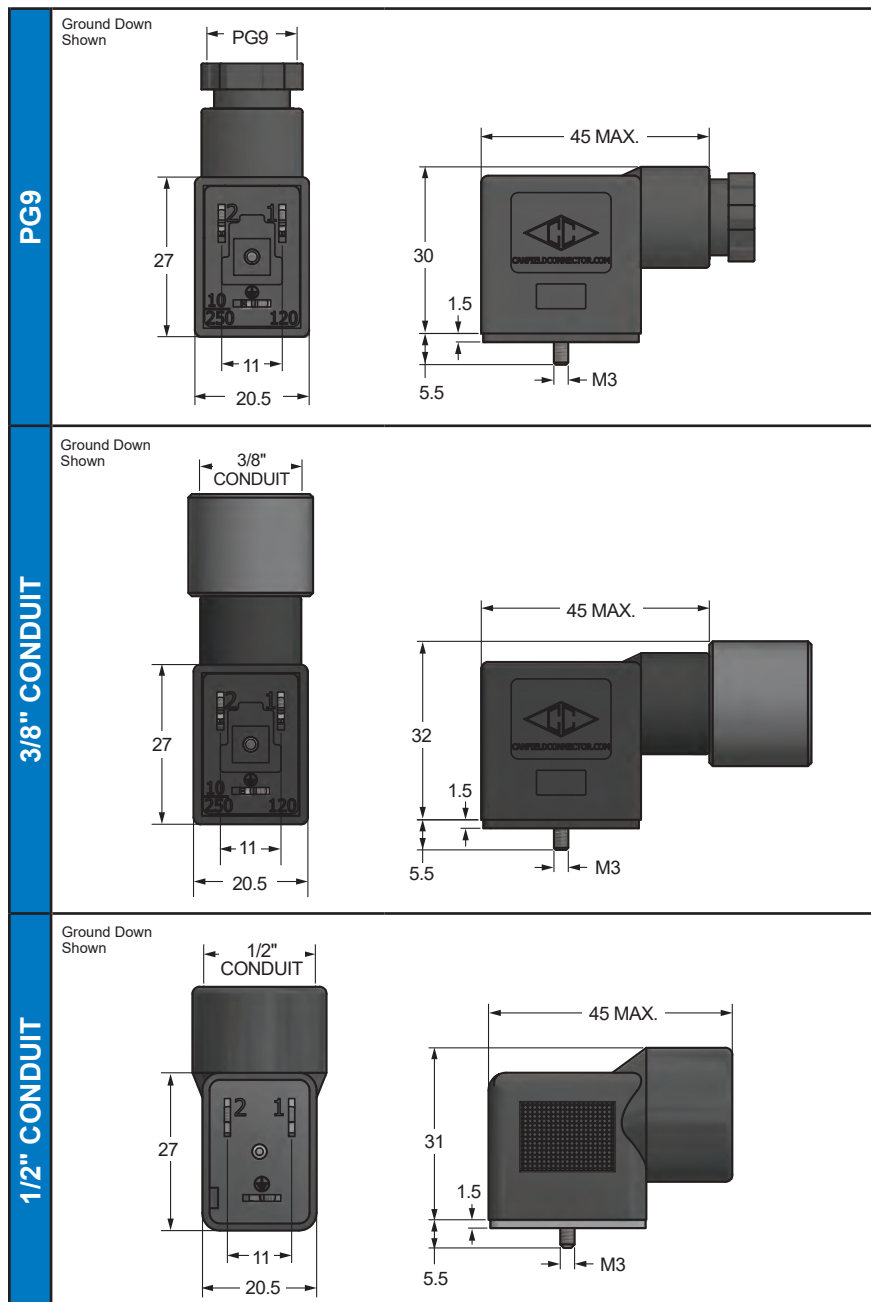

Consult factory for available versions listed by Canadian Standards Association for use with certified electrical equipment.

Technical Data

Current Max.	10 Amps
Voltage Max.	250 VAC 50/60 Hz, 300 VDC
Materials	Housing: Black; Gray; Translucent (lighted versions)
Gasket Temperature Max.	Nitrile: -25° to +90°C Silicone: -40° to +125°C
Environmental Protection	Designed for IP 65 / NEMA 4 Dust tight and water resistant
Cable Diameter	PG9 0.236" to 0.315" O.D. 3/8" Conduit 0.410" max. 1/2" Conduit 0.410" max.
Wire Gauge Max.	14 AWG
Size	MINI: 11mm pin spacing - Industry Standard
Number of Contacts	2+ ground

NOTE: Slight discoloration may occur to translucent material after prolonged exposure to UV rays.

Wiring Information

NORMAL POLARITY	
	Chassis Ground
1	(+) Pos. / High
2	(-) Neg. / Neut.

Derating Curve

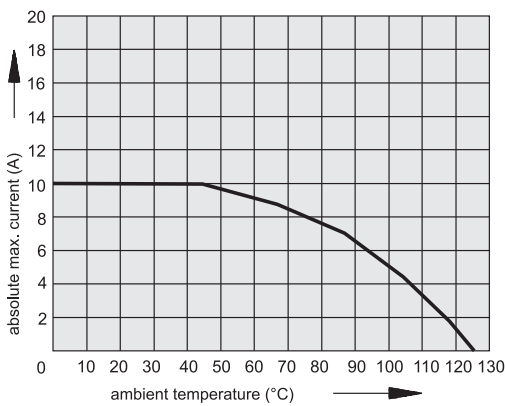

Ordering Information

Each connector kit contains screw, washer and gasket assembly.

Use a prefix of "G" for Individually Bagged

5 0 - 0 0 0 0 0 0

Orientation

1 - Ground down
Additional ground orientations available

Lighting Option

0 - Unlighted
3 - 6 - 48V AC/DC 50/60 Hz
7 - 48 - 120 VDC
100 - 240 VAC 50/60 Hz

Gasket

1 - Nitrile
2 - Silicone
3 - Nitrile profile

Housing Color

0 - Black "B" standard. Translucent if lighted.
1 - Gray "A"

Connector Types

01 - MINI strain relief PG9
02 - MINI 3/8" conduit
03 - MINI 1/2" conduit

For convenience and faster shipping, this series is available in Can-Paks.



Ordering Example: 5100-1010000

Ground down, Unlighted, Nitrile gasket, MINI strain relief PG9 connector, Black house

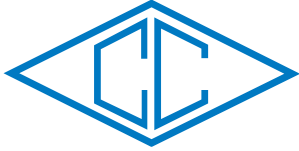

canfield connector
 8510 Foxwood Court
 Youngstown, Ohio 44514
 P:(330) 758-8299 F:(330) 758-8912
 www.canfieldconnector.com

5000 SERIES

**FIELD WIREABLE ISO
SOLENOID VALVE CONNECTOR**

General Description

Canfield Connector's 5000 Series ISO connector connects solenoid valves using the DIN Style "A" EN175301-803 (Formerly DIN 43650) specification. This standard permits industry interchangeability and has been embraced by the solenoid valve industry worldwide. Features include the ability for the user to wire the connector into existing installations or the connector can be pre wired at the factory. Wire connections are made inside the connector housing and the wire inlet is either PG9, PG11 or 1/2" conduit. Maximum current rating is 10 Amps with a maximum conductor size of 14 AWG with an outer jacket not to exceed .410 inches diameter. There are CSA approved versions as well as versions with indicator lights depicting the "on" state. The connectors are NEMA 4 and IP 65 environment rated.

Dimensional Data

ALL DIMENSIONS ARE IN MILLIMETERS UNLESS OTHERWISE NOTED

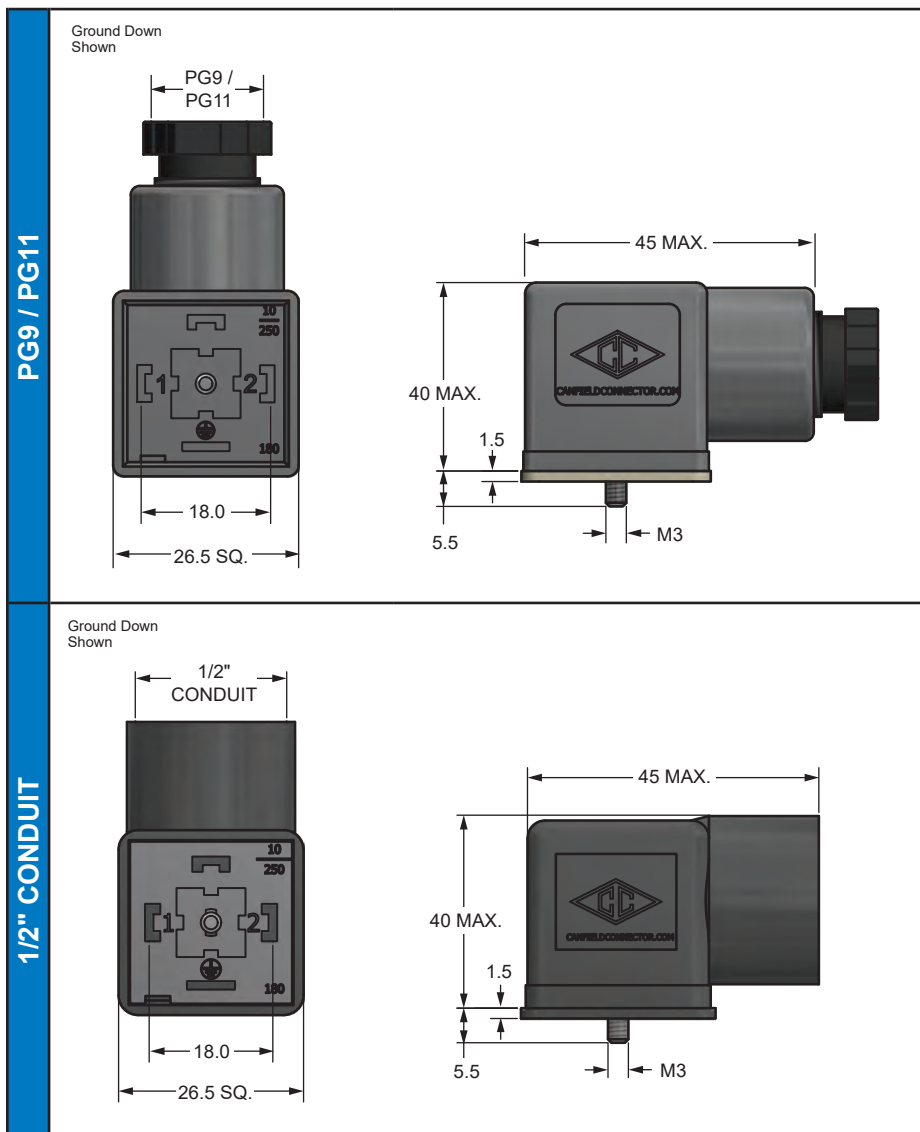

Consult factory for available versions listed by Canadian Standards Association for use with certified electrical equipment.

Technical Data

Current Max.	10 Amps
Voltage Max.	250 VAC 50/60 Hz, 300 VDC
Materials	Housing: Black; Gray; Translucent (lighted versions)
Gasket Temperature Max.	Nitrile: -25° to +90°C Silicone: -40° to +125°C
Environmental Protection	Designed for IP 65 / NEMA 4 Dust tight and water resistant
Cable Diameter	PG9 0.236" to 0.315" O.D. PG11 0.315" to 0.394" O.D. 1/2" Conduit 0.410" max.
Wire Gauge Max.	14 AWG
Size	ISO: 18mm pin spacing - DIN Style "A" EN175301-803
Number of Contacts	2+ ground 3+ ground

NOTE: Slight discoloration may occur to translucent material after prolonged exposure to UV rays.

Wiring Information

NORMAL POLARITY	
⊕	Chassis Ground
1	(+) Pos. / High
2	(-) Neg. / Neut.
3	Signal

Derating Curve

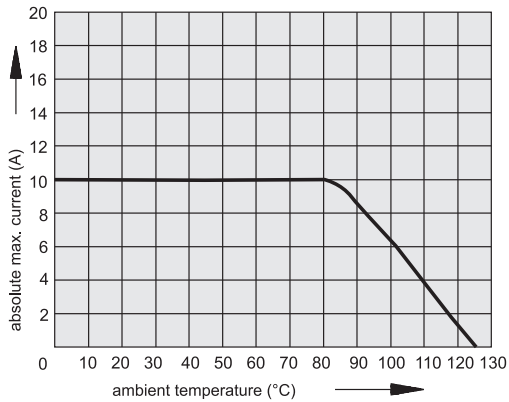

Ordering Information

Each connector kit contains screw, washer and gasket assembly.

Use a prefix of "G" for Individually Bagged

5 0 - 0 0 0

Orientation

1 - Ground down
Additional ground orientations available

Lighting Option

0 - Unlighted
3 - 6 - 48V AC/DC 50/60 Hz
7 - 48 - 120 VDC
100 - 240 VAC 50/60 Hz

Gasket

1 - Nitrile
2 - Silicone
3 - Nitrile profile

Housing Color

0 - Black "B" standard. Translucent if lighted.
1 - Gray "A"

Contacts

0 - 2+ ground
1 - 3+ ground

Connector Type

08 - ISO strain relief PG9
09 - ISO strain relief PG11
10 - ISO 1/2" conduit

For convenience and faster shipping, this series is available in Can-Paks.



Ordering Example: 5100-1080000

Ground down, Nitrile gasket, ISO strain relief PG9, 2+ ground contacts, Black house

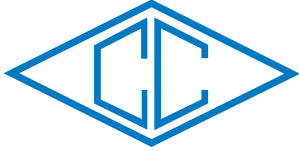

canfield connector
 8510 Foxwood Court
 Youngstown, Ohio 44514
 P:(330) 758-8299 F:(330) 758-8912
 www.canfieldconnector.com

5000 SERIES

FIELD WIREABLE SUB-MICRO SOLENOID VALVE CONNECTOR

General Description

Canfield Connector's 5000 Series Sub-Micro connector is made to connect solenoid valves using the DIN Style "C" EN 175301-803 (Formerly DIN 43650) 8mm pin center, and the industry standard 9.4mm pin center. These standards permit industry interchangeability and have been embraced by the solenoid valve industry worldwide. Features include the ability for the user to wire the connector into existing installations or the connector can be pre wired at the factory. Wire connections are made inside the connector housing. The wire inlet is either PG7 or 1/2" conduit. Maximum current rating is 6 amps with a maximum conductor size of 20 gauge with an outer jacket not to exceed .260 inches diameter. There are versions with indicator lights depicting the "on" state. The connectors are NEMA 4 and IP 65 environment rated.

Dimensional Data

ALL DIMENSIONS ARE IN MILLIMETERS UNLESS OTHERWISE NOTED

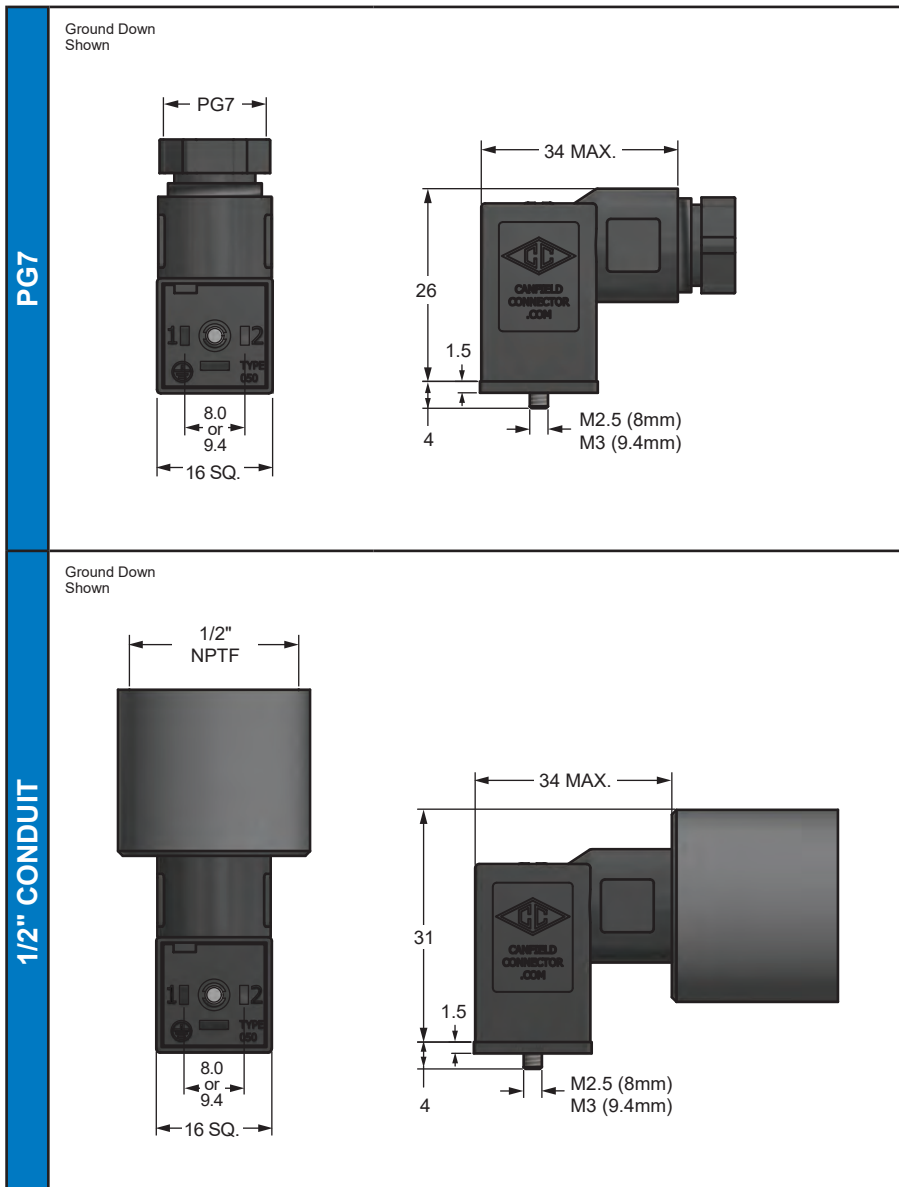

Consult factory for available versions listed by Canadian Standards Association for use with certified electrical equipment.

Technical Data

Current Max.	6 Amps
Voltage Max.	250 VAC 50/60 Hz, 250 VDC
Materials	Housing: Black; Gray; Translucent (lighted versions)
Gasket Temperature Max.	Nitrile: -25° to +90°C Silicone: -40° to +125°C
Environmental Protection	Designed for IP 65 / NEMA 4 Dust tight and water resistant
Cable Diameter	PG7 0.157" to 0.236" O.D. 1/2" Conduit 0.410" max.
Wire Gauge Max.	20 AWG
Size	Sub-Micro: 8mm pin spacing - DIN Style "C" EN 175301-803 Sub-Micro: 9.4mm pin spacing - Industry Standard
Number of Contacts	2+ ground 3+ ground (unlighted only)

NOTE: Slight discoloration may occur to translucent material after prolonged exposure to UV rays.

Wiring Information

NORMAL POLARITY	
⊕	Chassis Ground
1	(+) Pos. / High
2	(-) Neg. / Neut.
3	Signal

Derating Curve

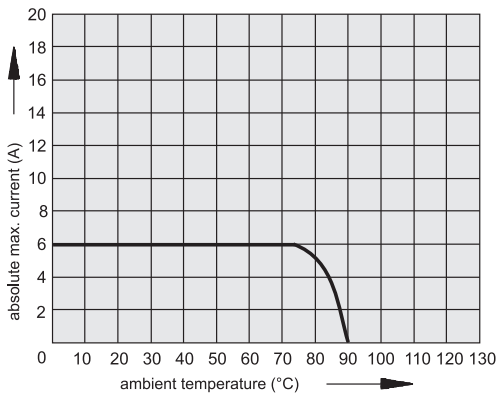

Ordering Information

Each connector kit contains screw, washer and gasket assembly.

Use a prefix of "G" for Individually Bagged

5 0 - - 0 0 0

Orientation

1 - Ground down
Additional ground orientations available

Lighting Option

0 - Unlighted
3 - 6 - 48V AC/DC 50/60 Hz
7 - 48 - 120 VDC
100 - 240 VAC 50/60 Hz

Gasket

1 - Nitrile
2 - Silicone

Housing Color

0 - Black "B" standard. Translucent if lighted.
1 - Gray "A"

Contacts

0 - 2+ ground
1 - 3+ ground*
*NOT available in lighted version.

Connector Type

90 - Sub-Micro strain relief PG7 DIN interface (8mm)
91 - Sub-Micro 1/2" conduit DIN interface (8mm)
95 - Sub-Micro 1/2" conduit (9.4mm)
99 - Sub-Micro strain relief PG7 (9.4mm)

For convenience and faster shipping, this series is available in Can-Paks.



Ordering Example: 5100-1900000

Ground down, unlighted, nitrile gasket, Sub-Micro strain relief PG7 DIN interface, 2+ ground contacts, black house

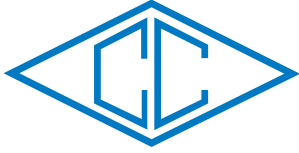

canfield connector
 8510 Foxwood Court
 Youngstown, Ohio 44514
 P:(330) 758-8299 F:(330) 758-8912
 www.canfieldconnector.com

FAC SERIES

7/8" AUTOMOTIVE FIELDBUS ADAPTER SOLENOID VALVE CONNECTORS

General Description

The FAC Series is Canfield Connector's solenoid valve connector series designed for automation. The FAC Series facilitates modern equipment construction by reducing assembly time and increasing productivity. Incorporating an American standard (Daniel Woodhead) 7/8" circular connector adapting to a female ISO DIN Style "A" EN175301-803 (Formerly DIN 43650) solenoid valve connections, the connector touts a rugged plug and play installation which conforms to environmental protection class IP65/NEMA 4 dust tight and water resistant. No hand wiring is involved, and the connector has optional indicator light and surge suppression which benefit rapid installation into modern field-bus systems.

Dimensional Data

ALL DIMENSIONS ARE IN MILLIMETERS UNLESS OTHERWISE NOTED

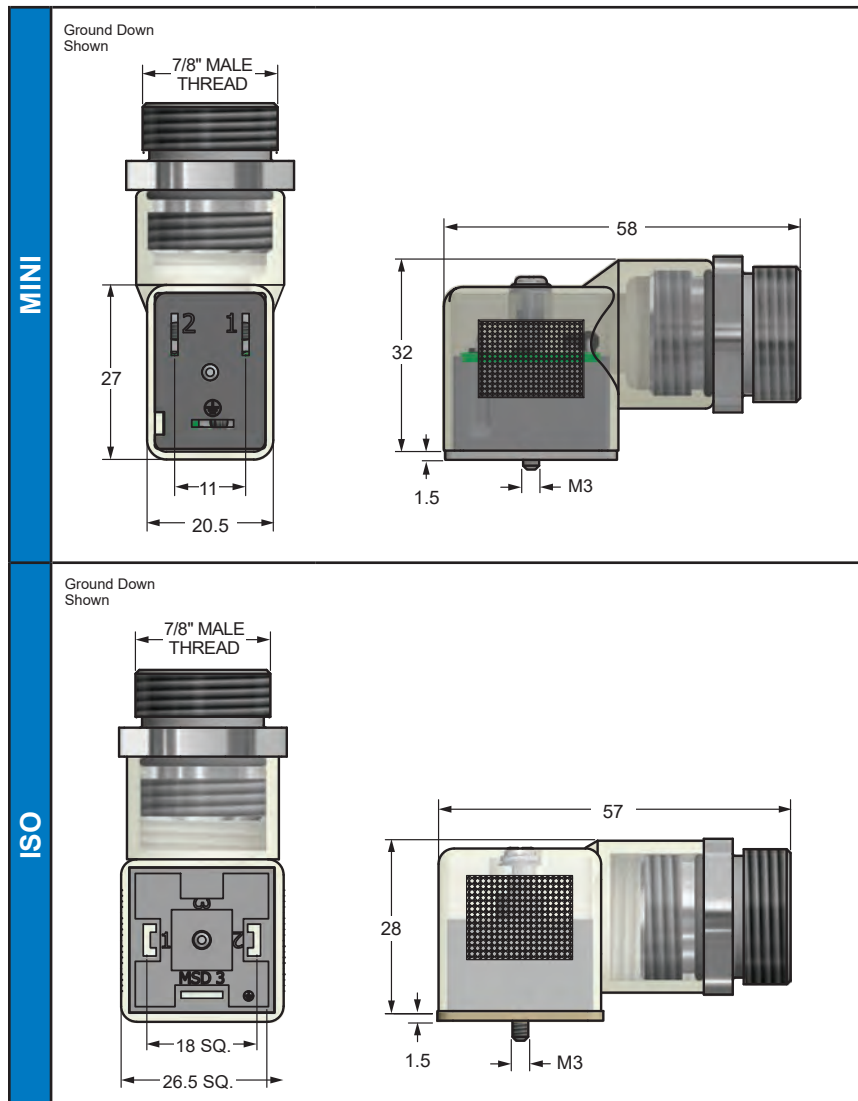

Consult factory for available versions listed by Canadian Standards Association for use with certified electrical equipment.

Technical Data

Current Max.	3 Pole: 4 Amps 5 Pole: 3 Amps
Voltage Max.	250 VAC 50/60 Hz, 300 VDC
Materials	Housing: PA, Black; PC, Translucent (lighted versions) Adaptor: Aluminum
Temperature Range	-25° to +85°C
Gasket Temperature Max.	Nitrile: -25° to +90°C
Environmental Protection	Designed for IP 65 / NEMA 4
Size	ISO: 18mm pin spacing - DIN Style "A" EN175301-803 MINI: 11mm pin spacing - Industry Standard
Number of Contacts	2+ ground 3+ ground

NOTE: Slight discoloration may occur to translucent material after prolonged exposure to UV rays.

Automotive Standard Circuit Types

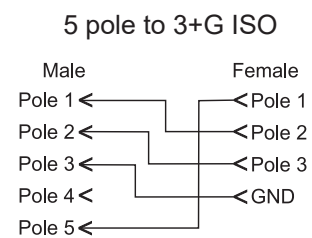
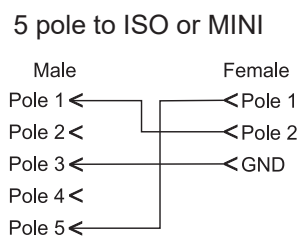
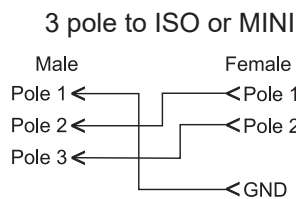

Pin Configuration

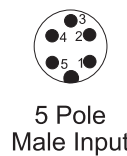
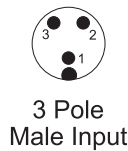

Ordering Information

Each connector kit contains screw, washer and gasket assembly.

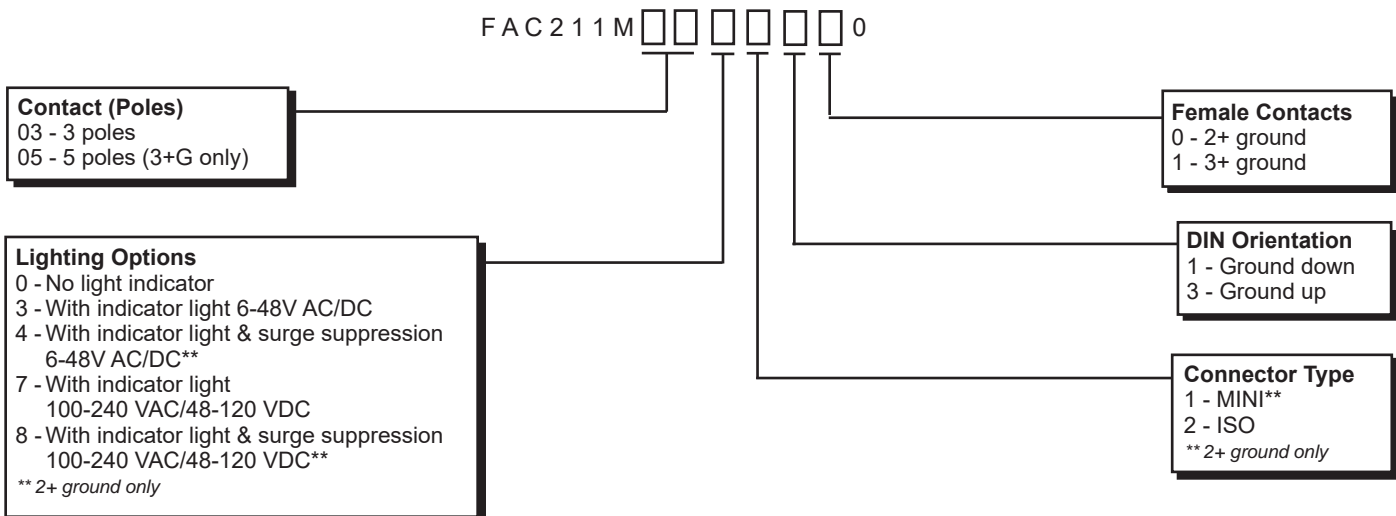

Ordering Example: FAC211M0302100

3 pole, No light, ISO, Ground down, 2+ ground

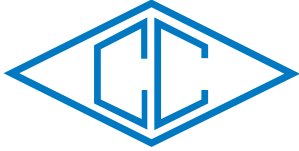

canfield connector
 8510 Foxwood Court
 Youngstown, Ohio 44514
 P:(330) 758-8299 F:(330) 758-8912
 www.canfieldconnector.com

FAC SERIES

**12MM FIELDBUS ADAPTER
 SOLENOID VALVE CONNECTORS**

General Description

The FAC Series 12MM Field-bus adapter is Canfield Connector's solenoid valve connector series designed for automation. The FAC Series facilitates modern equipment construction by reducing assembly time and increasing productivity. Incorporating an M12 circular connector input adapting to a female DIN Style EN175301-803 (Formerly DIN 43650) solenoid valve connections, the connector touts a rugged plug and play installation which conforms to environmental protection class IP65/ NEMA 4 dust tight and water resistant. No hand wiring is involved, and the connector has optional indicator light and surge suppression which benefit rapid installation into modern field-bus systems.

Dimensional Data

ALL DIMENSIONS ARE IN MILLIMETERS UNLESS OTHERWISE NOTED

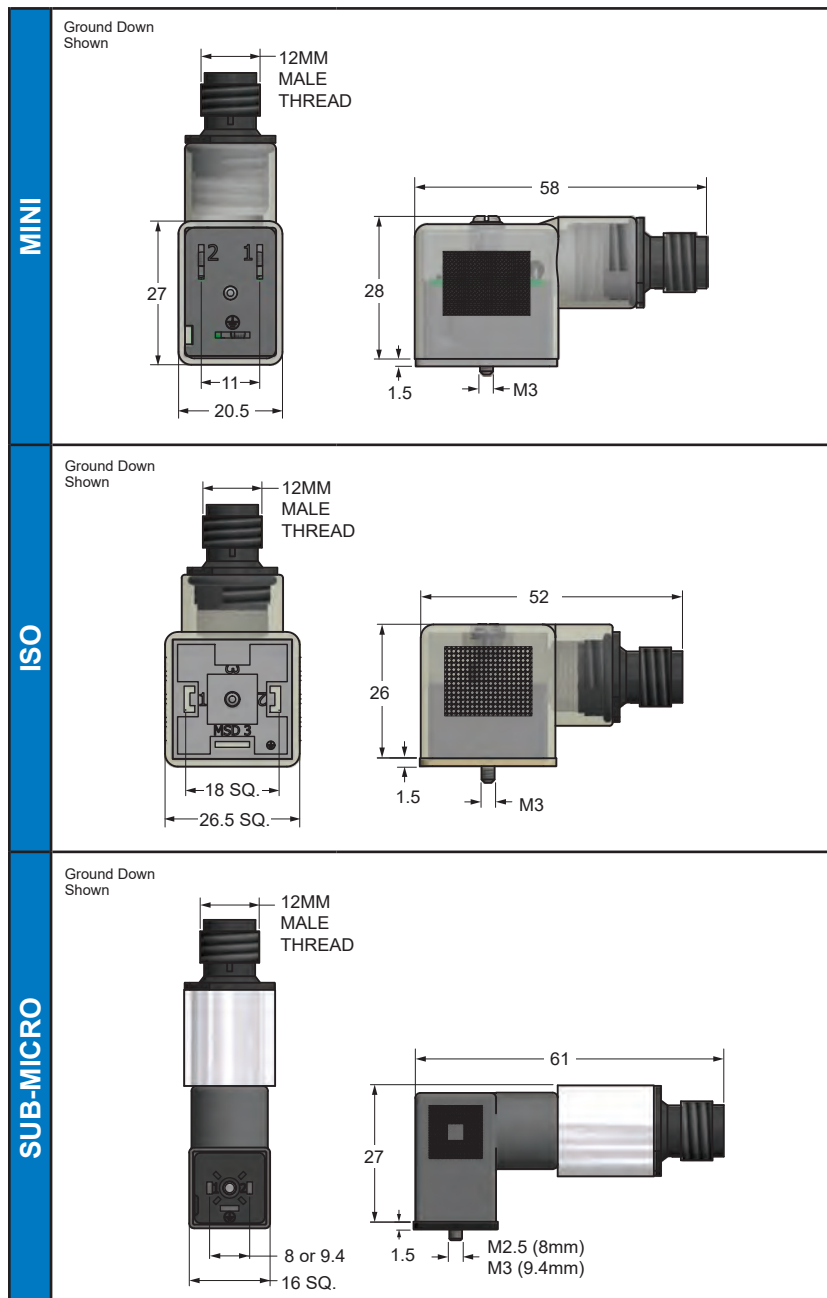

Consult factory for available versions listed by Canadian Standards Association for use with certified electrical equipment.

Technical Data

Current Max.	4 Pole: 4 Amps 5 Pole: 3 Amps
Voltage Max.	250 VAC 50/60 Hz, 300 VDC
Materials	Housing: PA, Black; PC, Translucent (lighted versions) Adaptor: Aluminum
Temperature Range	-25° to +85°C
Gasket Temperature Max.	Nitrile: -25° to +90°C
Environmental Protection	Designed for IP 65 / NEMA 4
Size	ISO: 18mm pin spacing - DIN Style "A" EN175301-803 MINI: 11mm pin spacing - Industry Standard Sub-Micro: 8mm pin spacing - DIN Style "C" EN 175301-803 Sub-Micro: 9.4mm pin spacing - Industry Standard
Number of Contacts	2+ ground

NOTE: Slight discoloration may occur to translucent material after prolonged exposure to UV rays.

Optional Circuit Types

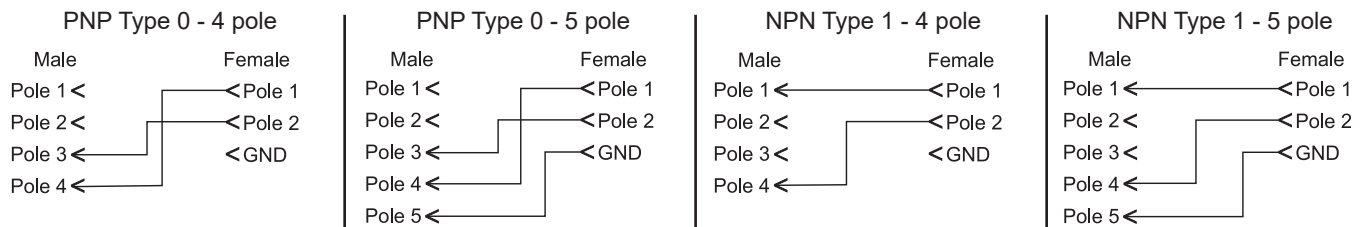

Pin Configuration

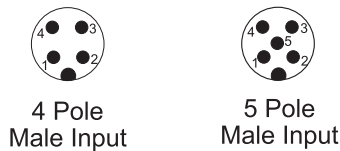

Ordering Information

Each connector kit contains screw, washer and gasket assembly.

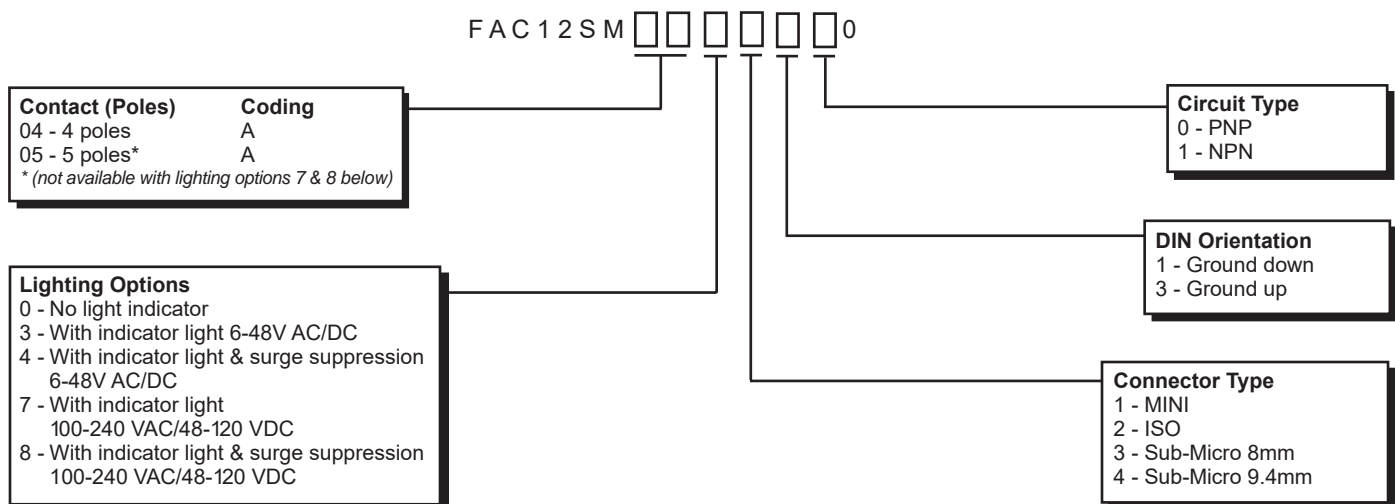

Ordering Example: FAC12SM0402100
4 pole, No light, ISO, Ground down, PNP

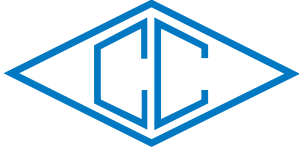

canfield connector
 8510 Foxwood Court
 Youngstown, Ohio 44514
 P:(330) 758-8299 F:(330) 758-8912
 www.canfieldconnector.com

P5600 SERIES Surge Suppression

MICRO PROTECTIVE CONNECTORS

General Description

The Canfield Connector P5600 Series Micro Protective Connectors are a complete line of field wire style solenoid valve connectors that are offered with internal surge suppression and indicators light options. The connectors are made to meet EN175301-803 (Formerly DIN 43650) solenoid valve connector standards in all styles and configurations. The rugged design features integrated cable strain reliefs or conduit versions. The surge suppression can be tailored to need with 6 distinct versions. These connectors are designed to work seamlessly with your choice of solenoid valve.

Dimensional Data

ALL DIMENSIONS ARE IN MILLIMETERS UNLESS OTHERWISE NOTED



ISO, Unlighted version shown above

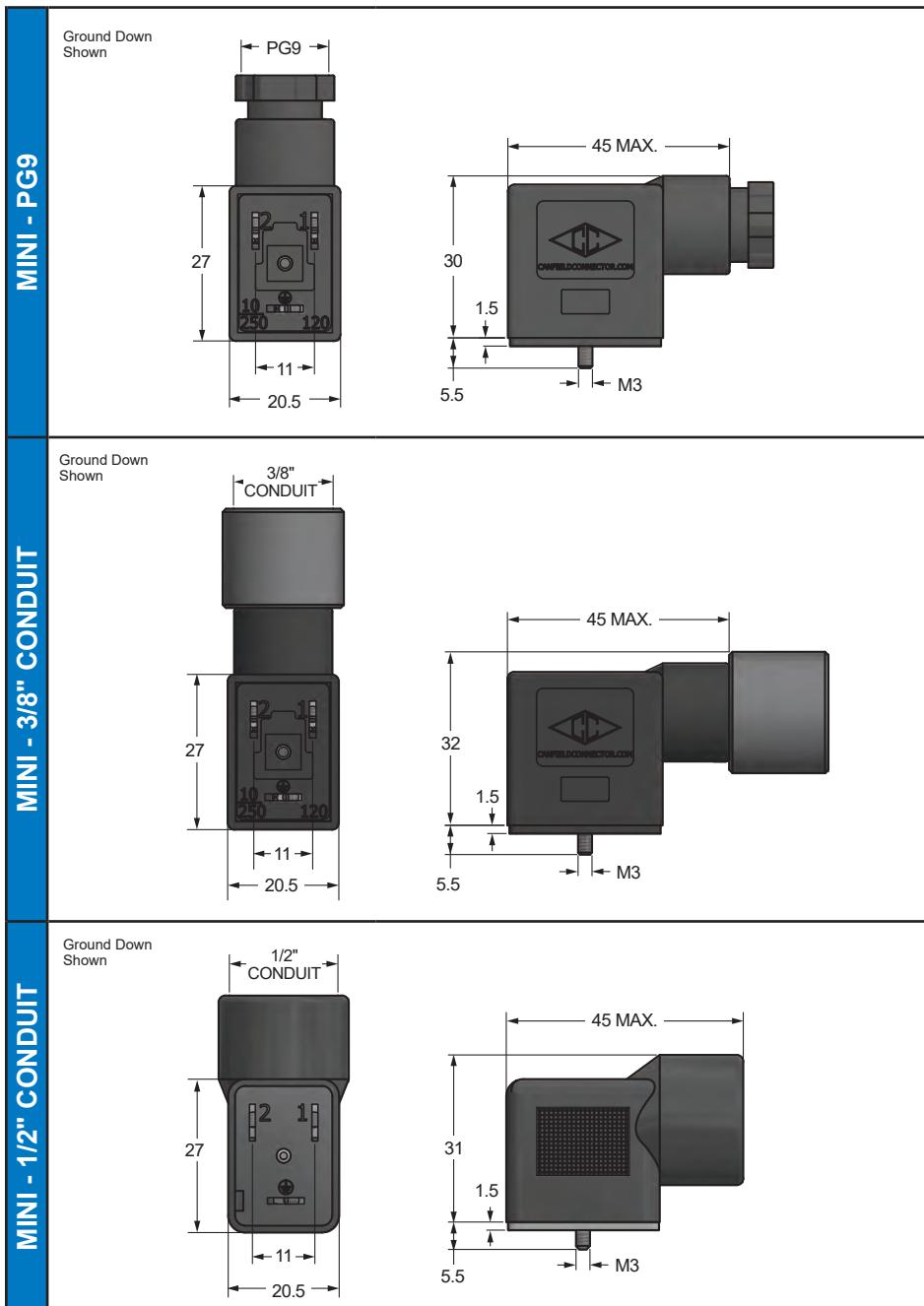

Dimensional Data Continued

ALL DIMENSIONS ARE IN MILLIMETERS UNLESS OTHERWISE NOTED

ISO - PG9 / PG11

Ground Down Shown

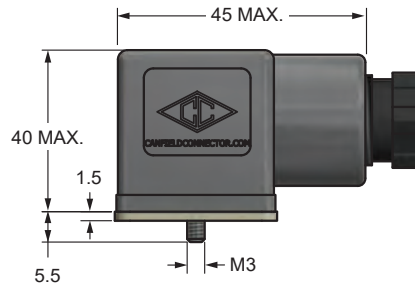

ISO - 1/2" CONDUIT

Ground Down Shown

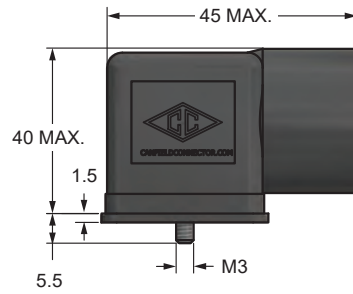

SUB-MICRO - PG7

Ground Down Shown

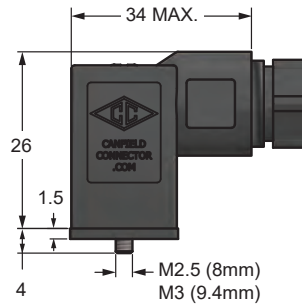

SUB-MICRO - 1/2\"/>

Ground Down Shown

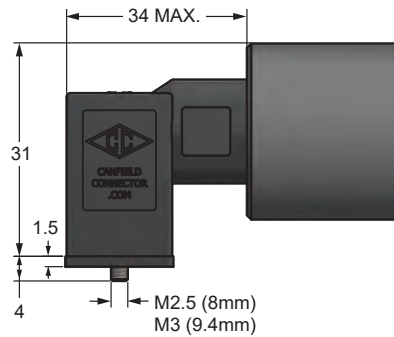
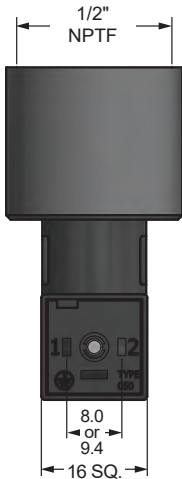

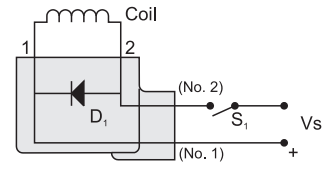
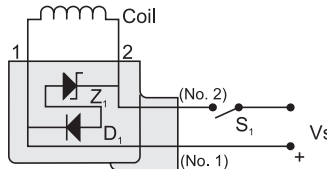
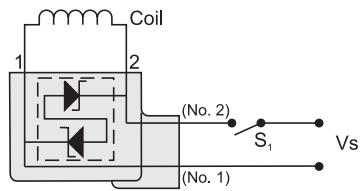
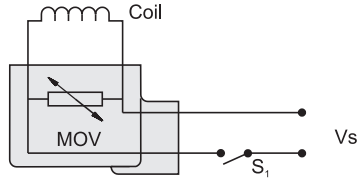
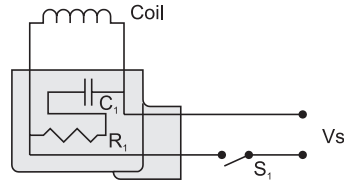
<p>TYPE 1*</p>	<ul style="list-style-type: none"> • Increases drop out time • Works only with DC voltage • Polarity dependent • Supply and switch are protected 	<p>Diode in parallel with coil. When switch (S_1) is opened, the energy stored in the coil is trapped and dissipated by the diode (D_1).</p>	
<p>TYPE 2</p>	<ul style="list-style-type: none"> • Exact limitation of inductive spikes • Works only with DC voltage • Polarity dependent • Supply and switch are protected 	<p>Diode & Zener in parallel with coil. When switch (S_1) is opened, the energy stored in the coil is trapped and dissipated by the diode (D_1) and zener diode (Z_1) and the coil resistance.</p>	
<p>TYPE 3</p>	<ul style="list-style-type: none"> • Good drop out time • Works with AC or DC voltage • NOT polarity dependent • Coil, supply and switch are protected 	<p>Transorb in parallel with coil. When switch (S_1) is opened or closed, the energy stored in the coil is limited by transorb.</p>	
<p>TYPE 5*</p>	<ul style="list-style-type: none"> • Good drop out time • Works with AC or DC voltage • NOT polarity dependent • Coil, supply and switch are protected 	<p>MOV (metal oxide varistor) in parallel with coil. When switch (S_1) is opened or closed, the energy stored in the coil is limited by the MOV.</p>	
<p>TYPE 6</p>	<ul style="list-style-type: none"> • Good drop out time • Works with AC or DC voltage • NOT polarity dependent • Coil, supply and switch are protected 	<p>RC Network in parallel with coil. When switch (S_1) is opened or closed, the energy stored in the coil is absorbed by the capacitor (C_1) and dissipated by the resistor (R_1).</p>	

*Most Commonly Used

Technical Data

Current Max.	Sub-Micro: 6 Amps ISO / MINI: 10 Amps
Voltage Max.	240 VAC, 120 VDC
Materials	Housing: PA, Black; Gray; Translucent (lighted versions)
Gasket Temperature Max.	Nitrile: -25° to +90°C Silicone: -40° to +125°C
Environmental Protection	Designed for IP 65 / NEMA 4 Dust tight and water resistant
Cable Diameter	PG7: 0.157" to 0.236" O.D. PG9: 0.236" to 0.315" O.D. PG11: 0.315" to 0.394" O.D. 1/2" Conduit 0.410" maximum
Wire Gauge	ISO / MINI: 14 AWG Max. Sub-Micro: 20 AWG Max.
Size	ISO: 18mm pin spacing - DIN Style "A" EN175301-803 MINI: 11mm pin spacing - Industry Standard Sub-Micro: 8mm pin spacing - DIN Style "C" EN 175301-803 Sub-Micro: 9.4mm pin spacing - Industry Standard
Number of Contacts	MINI: 2+ ground ISO / Sub-Micro: 2 contacts + 2 grounds

NOTE: Slight discoloration may occur to translucent material after prolonged exposure to UV rays.
NOTE: When using MAC Valves with MINI and 9.4mm Sub-Micro, consult our factory.

Wiring Information

NORMAL POLARITY	
	Chassis Ground
1	(+) Pos. / High
2	(-) Neg. / Neut.

Ordering Information

Each connector kit contains screw, washer and gasket assembly.

Use a prefix of "G" for Individually Bagged

P 5 0 - 0 0

Orientation

1 - Ground down
Additional ground orientations available

Operating Voltage

3 - 6 - 48 VDC
4 - 48 - 120 VDC
5 - 6 - 48 V AC/DC 50/60 Hz
6 - 48 - 120 V AC/DC 50/60 Hz
7 - 120 - 240 V AC/DC 50/60Hz

Gasket

1 - Nitrile
2 - Silicone
3 - Nitrile profile^{††}
^{††}NOT available in Sub-Micro

Housing Color

0 - Black "B" standard. Translucent if lighted.
1 - Gray "A"

Lighting Specification

0 - Unlighted
1 - Lighted

MPC Circuit

1 - Diode (DC Only)
2 - Diode & Zener diode (DC Only)
3 - Transorb (AC/DC)[†]
5 - MOV (AC/DC)
6 - RC network (AC/DC)
[†]NOT available in Operating Voltage option 7

Connector Type

3 - MINI strain relief PG9
4 - MINI 3/8" conduit
5 - MINI 1/2" conduit
6 - ISO strain relief PG9
7 - ISO strain relief PG11
8 - ISO 1/2" conduit
B - Sub-Micro strain relief PG7 (9.4mm)**
C - Sub-Micro 1/2" conduit (9.4mm)**
D - Sub-Micro strain relief PG7 (8mm)**
E - Sub-Micro 1/2" conduit (8mm)**
^{**}MPC Circuits 1 & 5 only

For convenience and faster shipping,
this series is available in Can-Paks.



Ordering Example: P5103-1311000

Ground down, 6-48 VDC, Nitrile gasket,
MINI strain relief PG9, Diode, Lighted

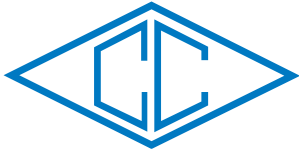

canfield connector
 8510 Foxwood Court
 Youngstown, Ohio 44514
 P:(330) 758-8299 F:(330) 758-8912
 www.canfieldconnector.com

R5000 SERIES

**ISO RECTIFIED
SOLENOID VALVE CONNECTORS**

General Description

Canfield Connector's R5000 Series solenoid valve connectors incorporate full-wave bridge rectifiers inside the DIN Style "A" EN175301-803 (Formerly DIN 43650) connectors. This standard permits industry interchange-ability and has been embraced by the solenoid valve industry worldwide. The R5000 converts alternating current to direct current reducing coil burnout due to valve sticking. Also, direct current eliminates AC "hum" inherent to alternating current. Features include the ability for the user to wire the connector into existing installations. Wire connections are made inside the connector housing and the wire inlet is either PG9, PG11 or 1/2" conduit. The R5000 has a maximum current rating of 1 Amp continuous with maximum wire gauge diameter of 14 AWG. An indicator light is offered for instant diagnostics and to aid setup and installation. The HT High Top connector accommodates larger wire gauge and easy installation.

Dimensional Data

ALL DIMENSIONS ARE IN MILLIMETERS UNLESS OTHERWISE NOTED

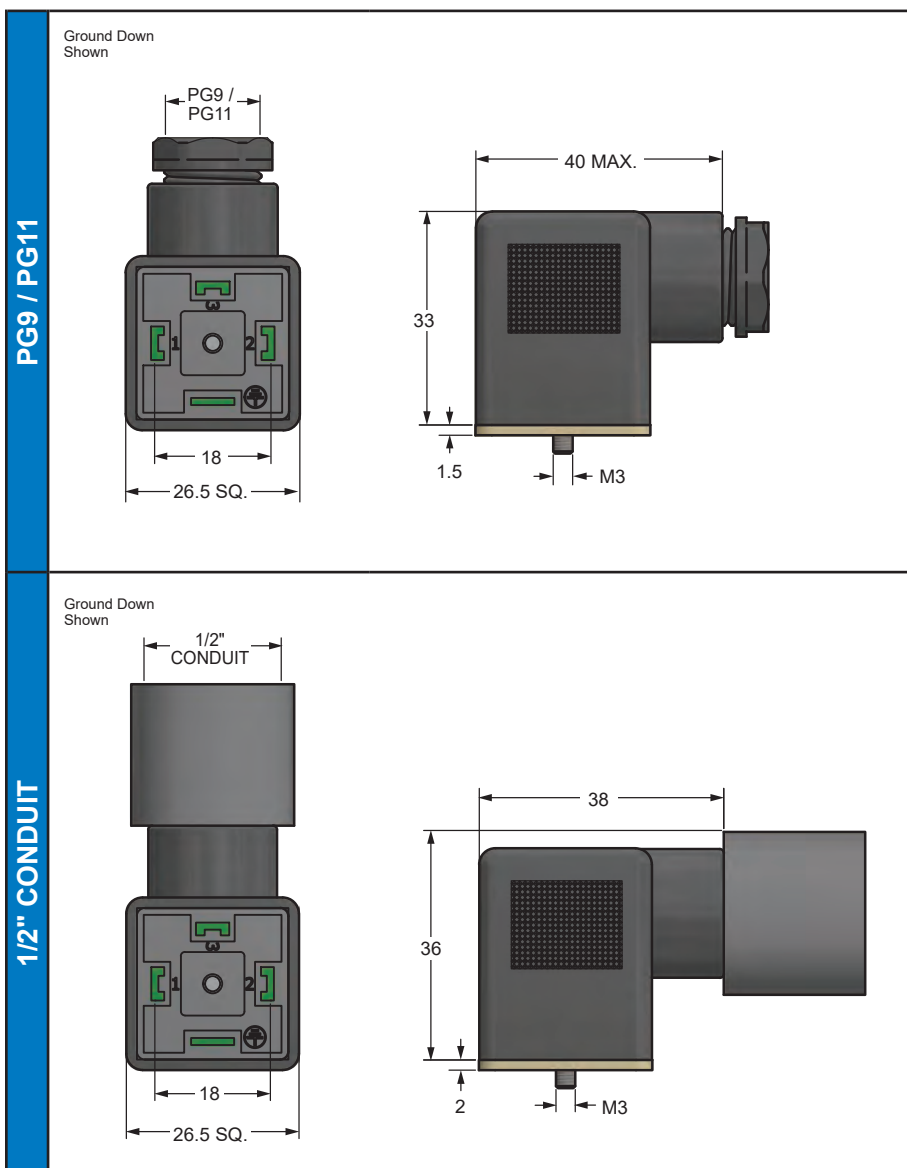

Consult factory for available versions listed by Canadian Standards Association for use with certified electrical equipment.

Technical Data

Current Max.	Continuous: 1 Amp Inrush: 15 Amps for 15 ms
Voltage Max.	250 VAC 50/60 Hz
Voltage Drop	2.2 Volt Max.
Materials	Housing: Black, Translucent (lighted styles)
Gasket Temperature Max.	Nitrile: -25° to +90°C Silicone: -40° to +125°C
Environmental Protection	IP 65 / NEMA 4, Dust tight and water resistant
Cable Diameter	PG9: 0.236" to 0.315" O.D. PG11: 0.315" to 0.394" O.D. 1/2" Conduit: 0.410" maximum
Wire Gauge	14 AWG
Size	ISO: 18mm pin spacing - DIN Style "A" EN175301-803
Number of Contacts	2+ ground (Pin 3 open spot)

NOTE: Slight discoloration may occur to translucent material after prolonged exposure to UV rays.

Wiring Information

NORMAL POLARITY	
	Chassis Ground
1	(+) Pos. / High
2	(-) Neg. / Neut.

Derating Curve

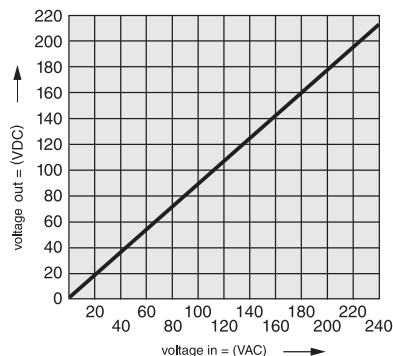
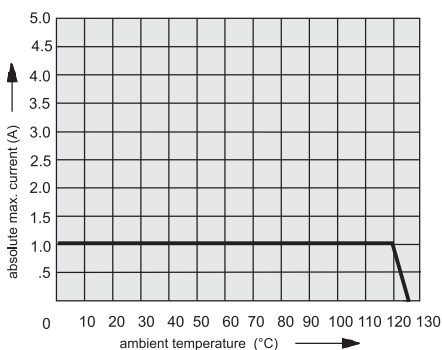

Schematic

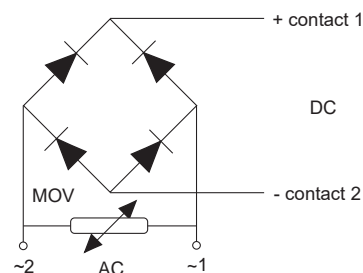

Ordering Information

Each connector kit contains screw, washer and gasket assembly.

Use a prefix of "G" for Individually Bagged

R 5 0 - 0 0 0 0

Orientation

1 - Ground down
Additional ground orientations available

Lighting Specification*

0 - Unlighted (black housing)
3 - 6 - 48 VAC 50/60 Hz (translucent housing)
7 - 100 - 240 VAC 50/60 Hz (translucent housing)

* Includes rated MOV suppression

Connector Types

08 - ISO High Top strain relief PG9
09 - ISO High Top strain relief PG11
10 - ISO High Top 1/2" conduit

Gasket

1 - Nitrile
2 - Silicone
3 - Nitrile profile

Ordering Example: R5100-1080000

Rectified, Ground down, Unlighted, Nitrile gasket, ISO HT strain relief PG9 connector

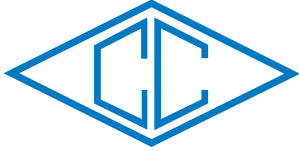

canfield connector
 8510 Foxwood Court
 Youngstown, Ohio 44514
 P:(330) 758-8299 F:(330) 758-8912
 www.canfieldconnector.com

M5 SERIES

MALE CONNECTORS

General Description

Canfield Connector M5 Series male connectors are used as electrical quick disconnect interfaces for pneumatic and hydraulic valves and sensors. They are available in standard Industry Standard MINI, DIN Style "A" EN175301-803 (Formerly DIN 43650), Sub-Micro 8mm DIN Style "C" EN 175301-803 (Formerly DIN 43650), Industry Standard 9.4mm, and conduit arrangements. These connectors are built to mate with the Canfield Connector DIN Style female connectors. Some male connectors are available with 2+ ground or 3+ ground terminal options.

Dimensional Data

ALL DIMENSIONS ARE IN MILLIMETERS UNLESS OTHERWISE NOTED



ISO, 1/2" Conduit version shown above

MINI - MOLDING

Ground Down Shown

M03010

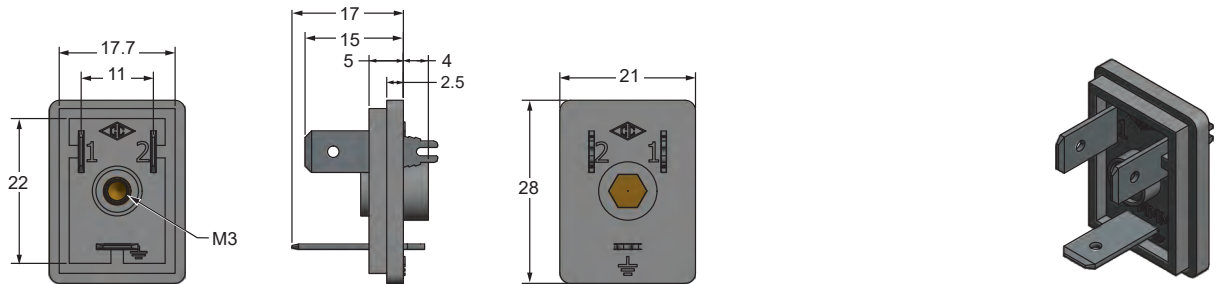

Used as an electrical quick connect during the molding, potting, or epoxying process for pneumatic and hydraulic valves or pressure switches.

MINI - PLATE MOUNT

Ground Down Shown

M03110

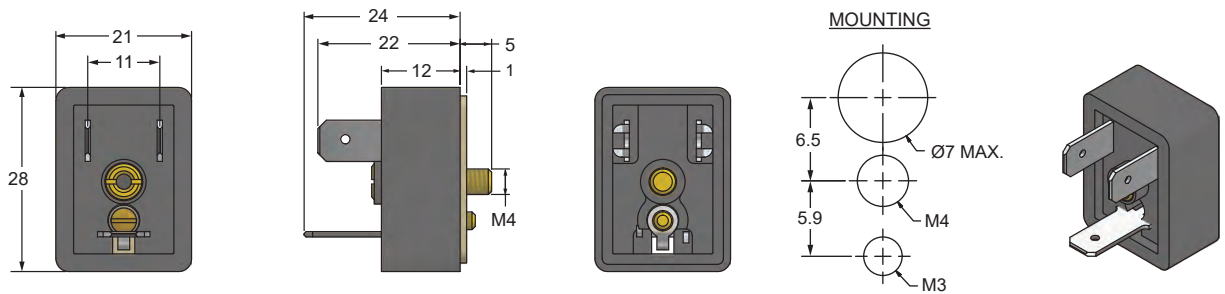

Used as an electrical quick connect for pneumatic and hydraulic valves.

Dimensional Data Continued

ALL DIMENSIONS ARE IN MILLIMETERS UNLESS OTHERWISE NOTED

ISO - MOLDING

Ground Down Shown

P10020

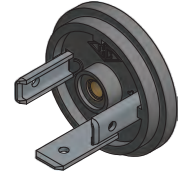
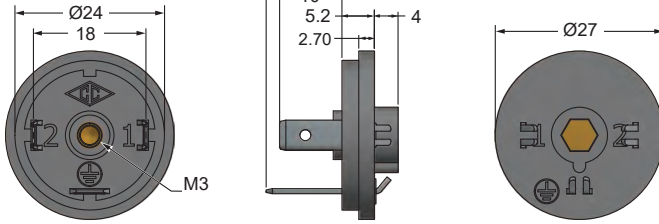

Used as an electrical quick connect during the molding, potting, or epoxying process for pneumatic and hydraulic valves or pressure switches.

ISO - PLATE MOUNT

Ground Down Shown

P10121

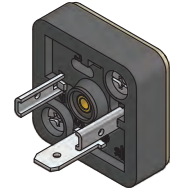
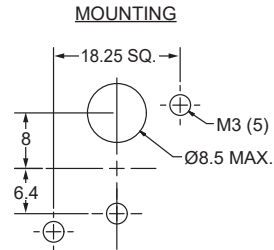
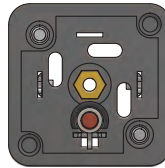
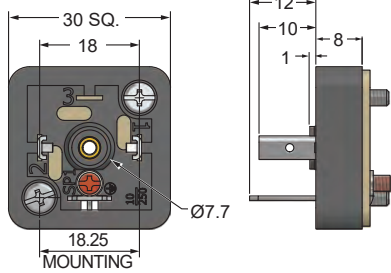

2 Hole - for panel or flat surface mounting.

ISO - PLATE MOUNT

Ground Down Shown

P10122

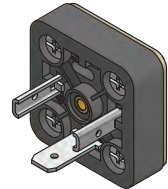
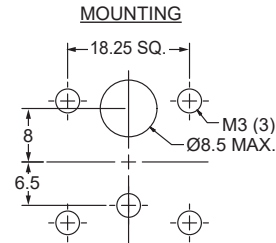
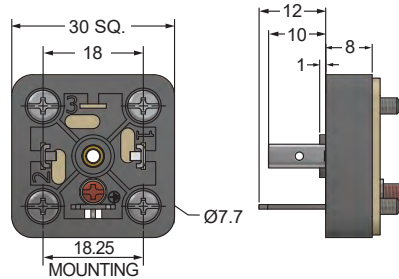

4 Hole - For high vibration, mobile applications.

ISO - SHEET METAL MOUNT

Ground Down Shown

P10222

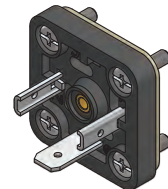
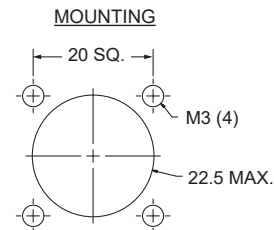
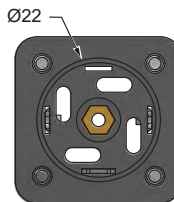
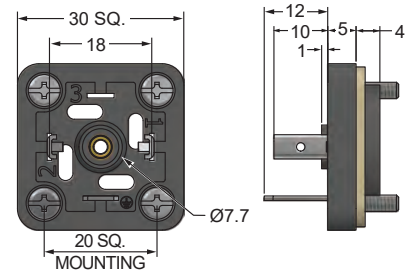

Has an arc over insulating plastic ridge for mounting in sheet metal.

ISO - 1/2" CONDUIT

Ground Down Shown

P10500

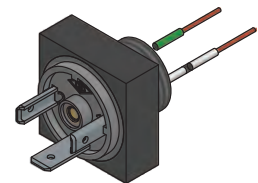
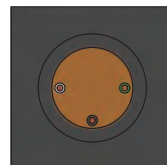
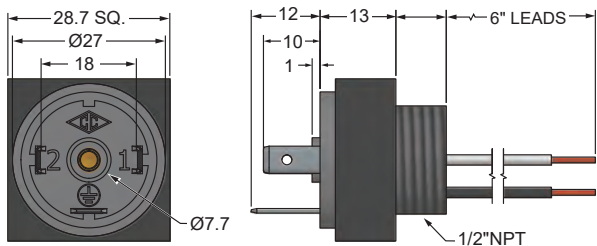

Designed to attach to systems with 1/2" conduit connections. Pre-wired for ease of installation and epoxy encapsulated in an aluminum shell with 1/2" NPTF Male Thread Connection.

Dimensional Data Continued

ALL DIMENSIONS ARE IN MILLIMETERS UNLESS OTHERWISE NOTED

SUB-MICRO 8MM - MOLDING

Ground Down Shown

P20020

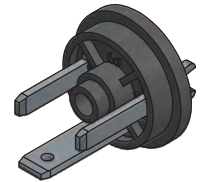
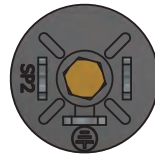
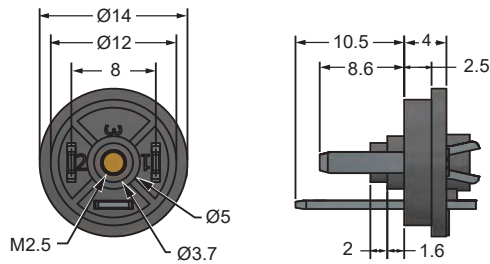

Used as an electrical quick connect during the molding, potting, or epoxying process for pneumatic valves or pressure switches.

SUB-MICRO 9.4MM - PLATE MOUNT

Ground Down Shown

P30120

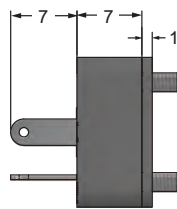
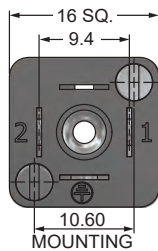

MOUNTING

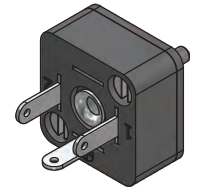
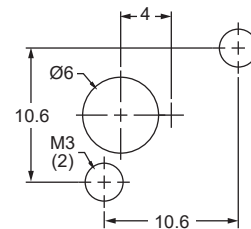

2 Hole – for panel or flat surface mounting.

Technical Data

Current Max.	ISO: 10 Amps MINI: 10 Amps Sub-Micro: 6 Amps
Voltage Max.	250V AC/DC
Materials	Glass Fiber Reinforced Nylon
Temperature Max.	Housing: -40° to +125°C (+105°C for ISO 1/2" Conduit)
Gasket Temperature Max.	Gasket: Nitrile, -25° to +90°C Silicone: -40° to +125°C
Wire Gauge	ISO Male for 1/2" Conduit: 18 AWG (6" leads)
Size	ISO: 18mm pin spacing - DIN Style "A" EN175301-803 MINI: 11mm pin spacing - Industry Standard Sub-Micro: 8mm pin spacing - DIN Style "C" EN 175301-803 Sub-Micro: 9.4mm pin spacing - Industry Standard
Number of Contacts	ISO: 2+ or 3+ground MINI: 2+ ground Sub-Micro: 2+ or 3+ ground

NOTE: When using MAC Valves with MINI and 9.4mm Sub-Micro, consult our factory.

Ordering Information

Each connector kit contains all mounting hardware.

M 5 - 0 0

Connector Type

- M03010 - MINI for molding
- M03110 - MINI for plate*
- P10020 - ISO for molding
- P10121 - ISO for plate 2 hole
- P10122 - ISO for plate 4 hole
- P10222 - ISO for sheet metal
- P10500 - ISO for 1/2" conduit
- P20020 - Sub-Micro 8mm molding
- P30120 - Sub-Micro 9.4mm for plate mount

* 2+ Ground Terminals Only

Contacts

- 2 - 2+ ground
- 3 - 3+ ground

Ordering Example: M5P10222-300

Model P10222 ISO for sheet metal, 3+ ground.

Connectors and Accessories

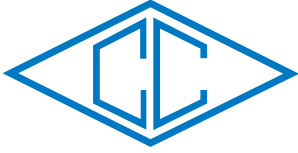

canfield connector
 8510 Foxwood Court
 Youngstown, Ohio 44514
 P:(330) 758-8299 F:(330) 758-8912
 www.canfieldconnector.com

iLW SERIES

INTERPOSED LIGHTED WAFER (MRO) RETRO-FIT INDICATOR LIGHT

General Description

The Canfield Connector iLW Series Interposed Lighted Wafer is an electronic, state of the art lighting module designed to install between a DIN type coil and the mating connector. Utilizing SMT (Surface Mount Technology), the iLW's ultra-thin design and high luminescence Gallium Arsenide LEDs enable the lighted wafer to retrofit existing applications or to be used in conjunction with unlighted connectors. Designed to "sandwich" between the connector and the coil, the iLW seals from dust and moisture. The iLW can be installed several times without degradation of the contact surfaces and is not polarity dependent.

Dimensional Data

ALL DIMENSIONS ARE IN MILLIMETERS UNLESS OTHERWISE NOTED

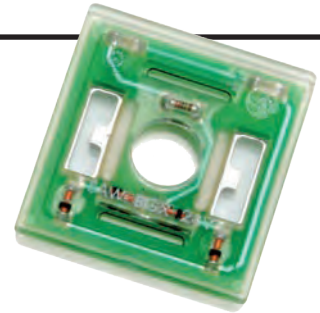
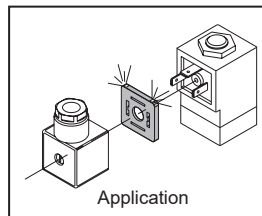
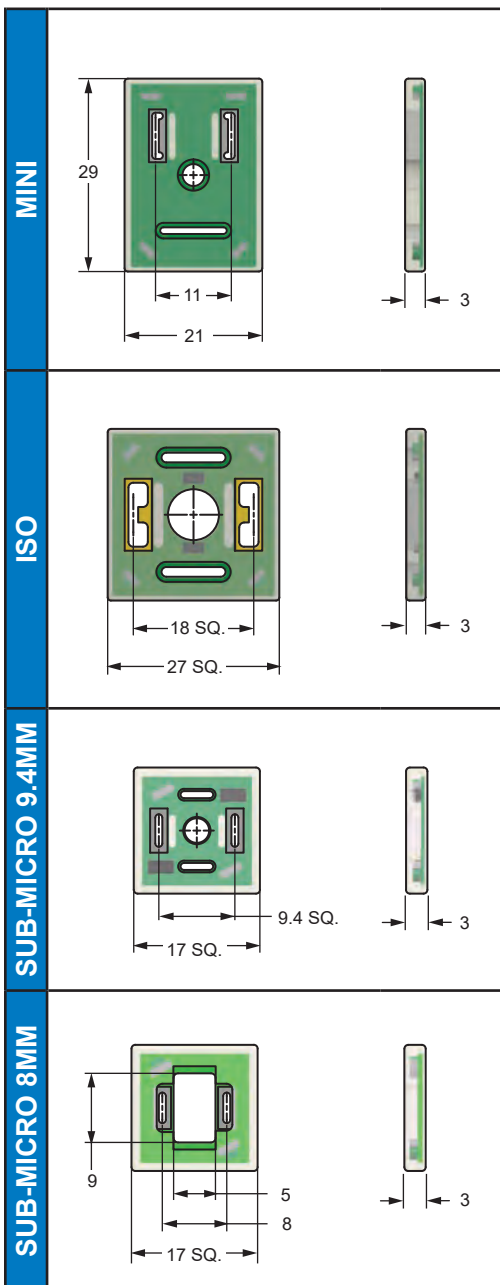

Technical Data

Voltage Max.	12-24 V AC/DC 10mA 120 VAC 6mA 240 VAC 9 mA
Materials	Housing: Polyurethane
Temperature Range	-20° to +90°C
Environmental Protection	Designed for IP 65 / NEMA 4 Dust tight and water resistant
Size	ISO: 18mm pin spacing - DIN Style "A" EN175301-803 MINI: 11mm pin spacing - Industry Standard Sub-Micro: 8mm pin spacing - DIN Style "C" EN 175301-803 Sub-Micro: 9.4mm pin spacing - Industry Standard
Number of Contacts	ISO: 2+ dual ground MINI: 2+ ground Sub-Micro: 2, 2+ dual ground

NOTE: Slight discoloration may occur to translucent material after prolonged exposure to UV rays.
 NOTE: When using MAC Valves with MINI and 9.4mm Sub-Micro, consult our factory.

Ordering Information

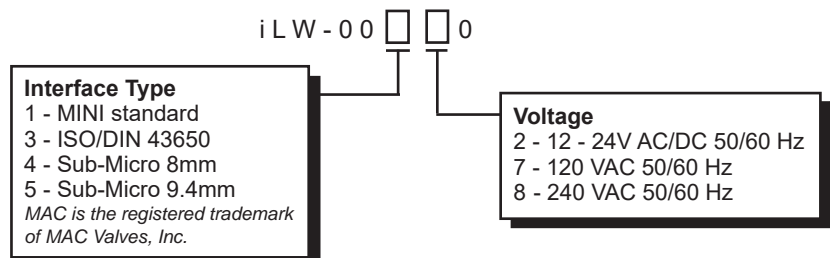

Ordering Example: iLW-00170
 MINI standard, 120 VAC 50/60 Hz.

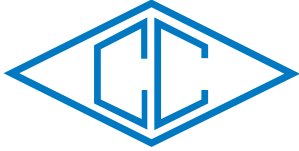

canfield connector
 8510 Foxwood Court
 Youngstown, Ohio 44514
 P:(330) 758-8299 F:(330) 758-8912
 www.canfieldconnector.com

DCP

**SOLENOID VALVE
 DIN COIL PROTECTORS**

General Description

The Canfield Connector DCP coil pin protectors are low cost replacements for solenoid connectors that ensure protection of solenoid terminals during shipping and handling. They can also be used to protect spade style terminals on a variety of other products. DCPs are available in a host of colors and styles as well as special logo markings to match the application. Constructed of low cost yet rugged polymers, the DCP adds aesthetic appeal and advertising value to the solenoid valve. There is a DCP available for ISO, industry standard MINI, Sub-Micro, and dual spade hydraulic coils.

Dimensional Data

ALL DIMENSIONS ARE IN MILLIMETERS UNLESS OTHERWISE NOTED



MINI	
ISO	
SUB-MICRO 9.4MM	
DUAL SPADE	

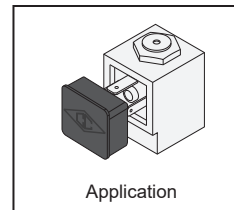

Technical Data

Materials	Housing: HDPE
Size	ISO: 18mm pin spacing - DIN Style "A" EN175301-803 MINI: 11mm pin spacing - Industry Standard Sub-Micro: 9.4mm pin spacing - Industry Standard Dual Spade: 13mm pin spacing
Colors	*Black standard. Many colors available upon request with nominal one time tooling charge and minimum quantity purchase of 20,000.

Ordering Information

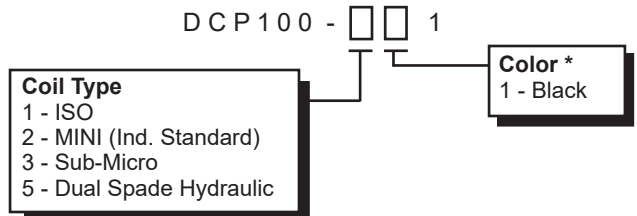

Ordering Example: DCP100 - 111
 DIN Coil Protector, ISO, black

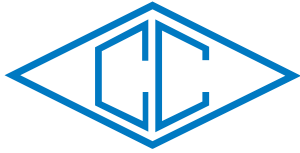

canfield connector
 8510 Foxwood Court
 Youngstown, Ohio 44514
 P:(330) 758-8299 F:(330) 758-8912
 www.canfieldconnector.com

CANGRIP SERIES

CORD GRIPS

General Description

The Canfield Connector CanGrip (brand) is a series of wire bulkhead feed through connectors which have integrated wire strain relief and sealing mechanism. The CanGrip are made from rugged engineered materials which are impervious to dust and moisture. Available in Nickel Plated Brass Strain Relief, Stainless Steel Strain Relief, Nylon Strain Relief, and Nylon Flex Strain Relief versions with various NPT, PG, and metric thread sizes. Features NBR seal material or EPDM on request. Canfield Connector CanGrips are compatible with wire diameters from .079" to 1.732" (.709" for Flex), to ensure a tight fit while enhancing any wire installation.

Dimensional Data

ALL DIMENSIONS ARE IN MILLIMETERS UNLESS OTHERWISE NOTED

Nickel Plated Brass Strain Relief Connectors

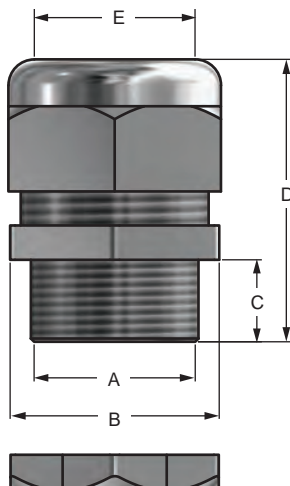

Ordering Information

DIMENSION					ORDER PART NUMBER
A	B (In)	C (In)	D (In)	E Range (In)	Brass
PG-7	0.630	0.315	1.181	0.118-0.256"	CANTOP-S010
				0.079-0.197"	CANTOP-S020
PG-9	0.748	0.315	1.339	0.157-0.315"	CANTOP-S030
				0.079-0.236"	CANTOP-S040
PG-11	0.866	0.315	1.378	0.197-0.394"	CANTOP-S050
				0.118-0.276"	CANTOP-S060
PG-13.5	0.945	0.354	1.457	0.236-0.472"	CANTOP-S070
				0.197-0.354"	CANTOP-S080
PG-16	1.063	0.394	1.575	0.394-0.551"	CANTOP-S090
				0.276-0.472"	CANTOP-S100
PG21	1.299	0.394	1.772	0.512-0.709"	CANTOP-S110
				0.354-0.630"	CANTOP-S120
PG-29	1.654	0.472	2.047	0.709-0.984"	CANTOP-S130
				0.512-0.787"	CANTOP-S140
PG-36	2.087	0.551	2.441	0.866-1.260"	CANTOP-S150
				0.787-1.024"	CANTOP-S160
PG-42	2.402	0.551	2.480	1.260-1.496"	CANTOP-S170
				0.984-1.220"	CANTOP-S180
PG-48	2.559	0.551	2.520	1.457-1.732"	CANTOP-S190
				1.142-1.378"	CANTOP-S200
NPT 3/8"	0.748	0.591	1.614	0.157-0.315"	CANTOP-S210
				0.079-0.236"	CANTOP-S220
NPT 1/2"	0.945	0.591	1.693	0.236-0.472"	CANTOP-S230
				0.197-0.354"	CANTOP-S240
NPT 3/4"	1.299	0.591	2.047	0.512-0.709"	CANTOP-S250
				0.354-0.630"	CANTOP-S260
NPT 1"	1.614	0.630	2.205	0.709-0.984"	CANTOP-S270
				0.512-0.787"	CANTOP-S280



Dimensional Data

ALL DIMENSIONS ARE IN MILLIMETERS UNLESS OTHERWISE NOTED

Stainless Steel Strain Relief Connectors

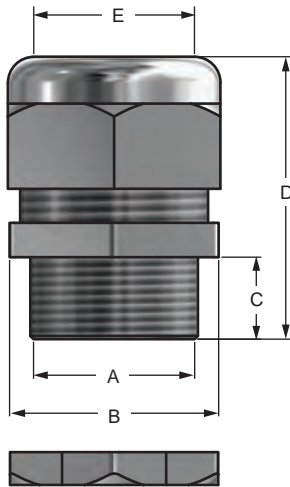

Ordering Information

DIMENSION					ORDER PART NUMBER
A	B (In)	C (In)	D (In)	E Range (In)	Stainless Steel
PG-7	0.630	0.315	1.181	0.118-0.256"	CANTOP-S013*
				0.079-0.197"	CANTOP-S023*
PG-9	0.748	0.315	1.339	0.157-0.315"	CANTOP-S033*
				0.079-0.236"	CANTOP-S043*
PG-11	0.866	0.315	1.378	0.197-0.394"	CANTOP-S053
				0.118-0.276"	CANTOP-S063*
PG-13.5	0.945	0.354	1.457	0.236-0.472"	CANTOP-S073*
				0.197-0.354"	CANTOP-S083*
PG-16	1.063	0.394	1.575	0.394-0.551"	CANTOP-S093*
				0.276-0.472"	CANTOP-S103*
PG21	1.299	0.394	1.772	0.512-0.709"	CANTOP-S113*
				0.354-0.630"	CANTOP-S123*
PG-29	1.654	0.472	2.047	0.709-0.984"	CANTOP-S133*
				0.512-0.787"	CANTOP-S143*
PG-36	2.087	0.551	2.441	0.866-1.260"	CANTOP-S153*
				0.787-1.024"	CANTOP-S163*
PG-42	2.402	0.551	2.480	1.260-1.496"	CANTOP-S173*
				0.984-1.220"	CANTOP-S183*
PG-48	2.559	0.551	2.520	1.457-1.732"	CANTOP-S193*
				1.142-1.378"	CANTOP-S203*
NPT 3/8"	0.748	0.591	1.614	0.157-0.315"	CANTOP-S213*
				0.079-0.236"	CANTOP-S223*
NPT 1/2"	0.945	0.591	1.693	0.236-0.472"	CANTOP-S233*
				0.197-0.354"	CANTOP-S243*
NPT 3/4"	1.299	0.591	2.047	0.512-0.709"	CANTOP-S253*
				0.354-0.630"	CANTOP-S263*
NPT 1"	1.614	0.630	2.205	0.709-0.984"	CANTOP-S273*
				0.512-0.787"	CANTOP-S283*

*Not a stocked item. Consult Factory.



Dimensional Data

ALL DIMENSIONS ARE IN MILLIMETERS UNLESS OTHERWISE NOTED

Nylon Strain Relief Connectors

Ordering Information

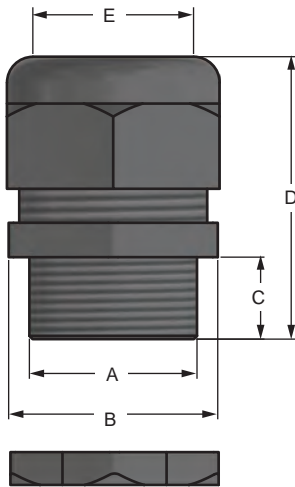

DIMENSION					ORDER PART NUMBER	
A	B (In)	C (In)	D (In)	E Range (In)	Gray	Black
PG-7	0.630	0.315	1.181	0.118-0.256"	CANTOP-S011	CANTOP-S012
				0.079-0.197"	CANTOP-S021	CANTOP-S022
PG-9	0.748	0.315	1.339	0.157-0.315"	CANTOP-S031	CANTOP-S032
				0.079-0.236"	CANTOP-S041	CANTOP-S042
PG-11	0.866	0.315	1.378	0.197-0.394"	CANTOP-S051	CANTOP-S052
				0.118-0.276"	CANTOP-S061	CANTOP-S062
PG-13.5	0.945	0.354	1.457	0.236-0.472"	CANTOP-S071	CANTOP-S072
				0.197-0.354"	CANTOP-S081	CANTOP-S082
PG-16	1.063	0.394	1.575	0.394-0.551"	CANTOP-S091	CANTOP-S092
				0.276-0.472"	CANTOP-S101	CANTOP-S102
PG21	1.299	0.394	1.772	0.512-0.709"	CANTOP-S111	CANTOP-S112
				0.354-0.630"	CANTOP-S121	CANTOP-S122
PG-29	1.654	0.472	2.047	0.709-0.984"	CANTOP-S131	CANTOP-S132
				0.512-0.787"	CANTOP-S141	CANTOP-S142
PG-36	2.087	0.551	2.441	0.866-1.260"	CANTOP-S151	CANTOP-S152
				0.787-1.024"	CANTOP-S161	CANTOP-S162
PG-42	2.402	0.551	2.480	1.260-1.496"	CANTOP-S171	CANTOP-S172
				0.984-1.220"	CANTOP-S181	CANTOP-S182
PG-48	2.559	0.551	2.520	1.457-1.732"	CANTOP-S191	CANTOP-S192
				1.142-1.378"	CANTOP-S201	CANTOP-S202
NPT 3/8"	0.748	0.591	1.614	0.157-0.315"	CANTOP-S211	CANTOP-S212
				0.079-0.236"	CANTOP-S221	CANTOP-S222
NPT 1/2"	0.945	0.591	1.693	0.236-0.472"	CANTOP-S231	CANTOP-S232
				0.197-0.354"	CANTOP-S241	CANTOP-S242
NPT 3/4"	1.299	0.591	2.047	0.512-0.709"	CANTOP-S251	CANTOP-S252
				0.354-0.630"	CANTOP-S261	CANTOP-S262
NPT 1"	1.614	0.630	2.205	0.709-0.984"	CANTOP-S271	CANTOP-S272
				0.512-0.787"	CANTOP-S281	CANTOP-S282
M12X1.5	0.630	0.315	1.181	0.118-0.256"	CANTOP-S291*	CANTOP-S292*
				0.079-0.197"	CANTOP-S301*	CANTOP-S302*
M16X1.5	0.748	0.315	1.339	0.157-0.315"	CANTOP-S311*	CANTOP-S312*
				0.079-0.236"	CANTOP-S321*	CANTOP-S322*
M18X1.5	0.866	0.315	1.378	0.197-0.394"	CANTOP-S331*	CANTOP-S332*
				0.118-0.276"	CANTOP-S341*	CANTOP-S342*
M20X1.5	0.945	0.354	1.456	0.236-0.472"	CANTOP-S351*	CANTOP-S352*
				0.197-0.354"	CANTOP-S361*	CANTOP-S362*
M22X1.5	1.063	0.394	1.575	0.394-0.551"	CANTOP-S371*	CANTOP-S372*
				0.276-0.472"	CANTOP-S381*	CANTOP-S382*
M25X1.5	1.300	0.394	1.772	0.512-0.709"	CANTOP-S391*	CANTOP-S392*
				0.354-0.630"	CANTOP-S401*	CANTOP-S402*
M32X1.5	1.437	0.433	2.008	0.709-0.984"	CANTOP-S411*	CANTOP-S412*
				0.512-0.787"	CANTOP-S421*	CANTOP-S422*
M40X1.5	2.067	1.575	3.465	0.866-1.260"	CANTOP-S431*	CANTOP-S432*
				0.787-1.024"	CANTOP-S441*	CANTOP-S442*
M50X1.5	2.382	1.575	3.504	1.260-1.496"	CANTOP-S451*	CANTOP-S452*
				0.984-1.220"	CANTOP-S461*	CANTOP-S462*
M63X1.5	2.638	1.575	3.544	1.457-1.732"	CANTOP-S471*	CANTOP-S472*
				1.142-1.378"	CANTOP-S481*	CANTOP-S482*

*Not a stocked item. Consult Factory.



Dimensional Data

ALL DIMENSIONS ARE IN MILLIMETERS UNLESS OTHERWISE NOTED

Nylon Flex Connectors

Ordering Information

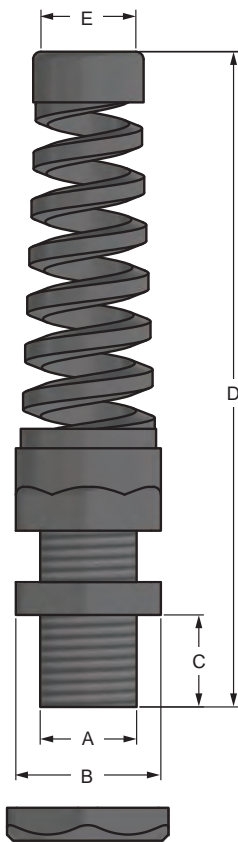

DIMENSION					ORDER PART NUMBER	
A	B (In)	C (In)	D (In)	E Range (In)	Gray	Black
PG-7	0.669	0.315	2.874	0.118-0.256"	CANTOP-F011	CANTOP-F012
				0.079-0.197"	CANTOP-F021	CANTOP-F022
PG-9	0.787	0.315	3.071	0.157-0.315"	CANTOP-F031	CANTOP-F032
				0.079-0.236"	CANTOP-F041	CANTOP-F042
PG-11	0.866	0.315	3.386	0.197-0.394"	CANTOP-F051	CANTOP-F052
				0.118-0.276"	CANTOP-F061	CANTOP-F062
PG-13.5	0.945	0.354	3.898	0.236-0.472"	CANTOP-F071	CANTOP-F072
				0.197-0.354"	CANTOP-F081	CANTOP-F082
PG-16	1.063	0.394	4.331	0.394-0.551"	CANTOP-F091	CANTOP-F092
				0.276-0.472"	CANTOP-F101	CANTOP-F102
PG21	1.339	0.394	4.803	0.512-0.709"	CANTOP-F111	CANTOP-F112
				0.354-0.630"	CANTOP-F121	CANTOP-F122
NPT 3/8"	0.787	0.591	3.346	0.157-0.315"	CANTOP-F271	CANTOP-F272
				0.079-0.236"	CANTOP-F281	CANTOP-F282
NPT 1/2"	0.945	0.591	4.134	0.236-0.472"	CANTOP-F291	CANTOP-F292
				0.197-0.354"	CANTOP-F301	CANTOP-F302
NPT 3/4"	1.339	0.591	5.079	0.512-0.709"	CANTOP-F311	CANTOP-F312
				0.354-0.630"	CANTOP-F321	CANTOP-F322
M12X1.5	0.669	0.315	2.874	0.118-0.256"	CANTOP-F131	CANTOP-F132
				0.079-0.197"	CANTOP-F141*	CANTOP-F142
M16X1.5	0.787	0.315	3.071	0.157-0.315"	CANTOP-F151	CANTOP-F152
				0.079-0.236"	CANTOP-F161*	CANTOP-F162*
M18X1.5	0.866	0.315	3.386	0.197-0.394"	CANTOP-F171	CANTOP-F172
				0.118-0.276"	CANTOP-F181*	CANTOP-F182*
M20X1.5	0.945	0.354	3.898	0.236-0.472"	CANTOP-F191	CANTOP-F192
				0.197-0.354"	CANTOP-F201*	CANTOP-F202*
M22X1.5	1.063	0.394	4.331	0.394-0.551"	CANTOP-F211	CANTOP-F212
				0.276-0.472"	CANTOP-F221	CANTOP-F222*
M25X1.5	1.339	0.394	4.803	0.512-0.709"	CANTOP-F231	CANTOP-F232
				0.354-0.630"	CANTOP-F241*	CANTOP-F242*

*Not a stocked item. Consult Factory.



Technical Data

Materials	Plastic Housing; Nylon Metal Housing: Nickel Plated Brass, or Stainless Steel Grommet: NBR (EPDM available on request)
Temp Range	-40° to +100°C
Environmental Protection	Designed for IP 68 / NEMA 6
Size	Strain Relief: .079" - 1.732" Flex: 0.79" - .709"

Ordering Example: CANTOP-F011

Nylon Flex CanGrip, PG-7, 0.118-0.256", Gray

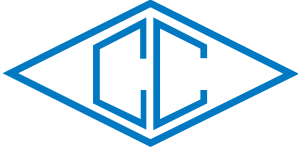

canfield connector
 8510 Foxwood Court
 Youngstown, Ohio 44514
 P:(330) 758-8299 F:(330) 758-8912
 www.canfieldconnector.com

ROUND CONNECTORS

FIELD WIREABLE OR MOLDED LOCKING
 FOR USE WITH PROXIMITY DEVICES

Dimensional Data

ALL DIMENSIONS ARE IN MILLIMETERS UNLESS OTHERWISE NOTED

Round Connectors

8MM FEMALE

Field Wireable Connector
 Conductor termination: Screw terminal

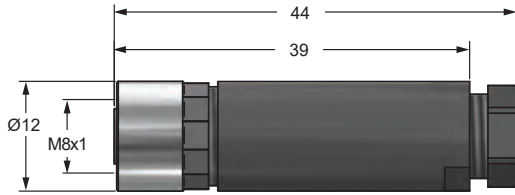

120V AC/DC 4 Amps max.



ORDER PART NUMBER

RC08B-F0F0330 (3 pin / 3-5mm cable dia.)



8MM MALE

Field Wireable Connector
 Conductor termination: Screw terminal

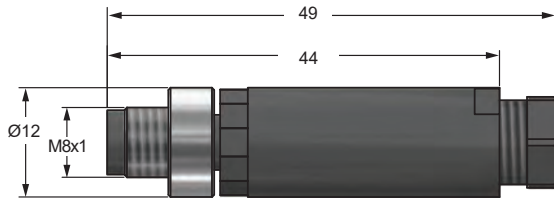

120V AC/DC 4 Amps max.



ORDER PART NUMBER

RC08B-M0F0330 (3 pin / 3-5mm cable dia.)

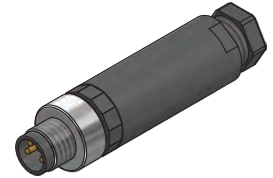

12MM FEMALE

Field Wireable Connector
 Conductor termination: Screw terminal

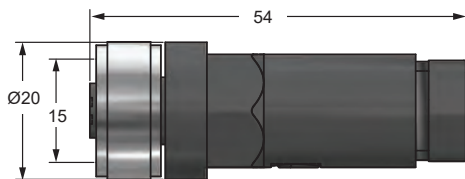

250V AC/DC 3 Amps max.



ORDER PART NUMBER

RC12B-F0F0400 (4 pin / 4-6mm cable dia.)
 RC12B-F0F0401 (4 pin / 6-8mm cable dia.)

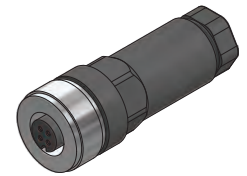

12MM MALE

Field Wireable Connector
 Conductor termination: Screw terminal

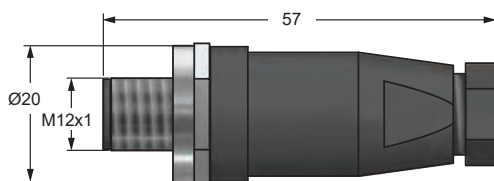

250V AC/DC 3 Amps max.



ORDER PART NUMBER

RC12B-M0F0400 (4 pin / 4-6mm cable dia.)
 RC12B-M0F0401 (4 pin / 6-8mm cable dia.)

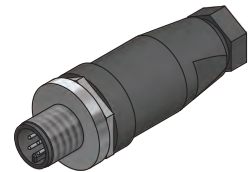

Dimensional Data Cont.

ALL DIMENSIONS ARE IN MILLIMETERS UNLESS OTHERWISE NOTED

8MM FEMALE

Molded Locking Connector

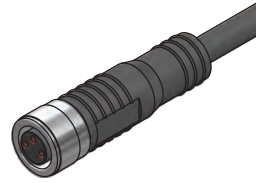
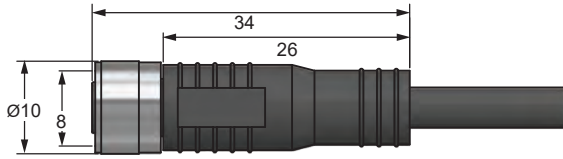

ORDER PART NUMBER

RC08S-F0M030120	(3 pin / 2m)
RC08S-F0M030150	(3 pin / 5m)
RC08S-F0M040120	(4 pin / 2m)
RC08S-F0M040150	(4 pin / 5m)



120V AC/DC 4 Amps max.

12MM FEMALE

Molded Locking Connector

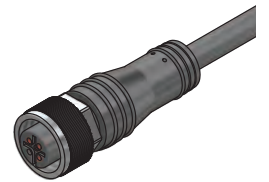
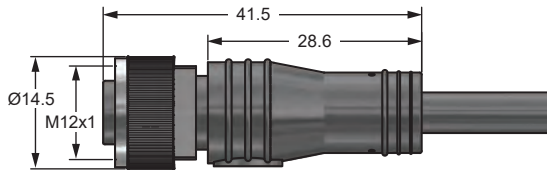

ORDER PART NUMBER

RC12S-F0M030120	(3 pin / 2m)
RC12S-F0M030150	(3 pin / 5m)



250V AC/DC 4 Amps max.

12MM MALE X 8MM FEMALE

Molded Locking Cable

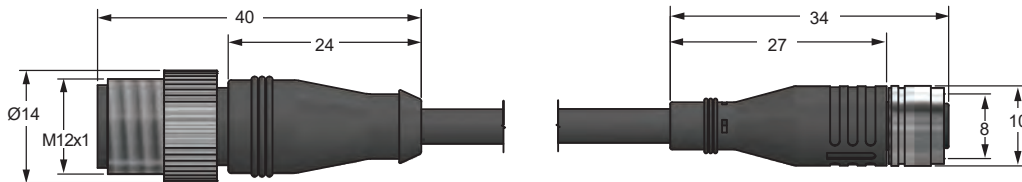

ORDER PART NUMBER

RCA-12SM00-08SF00-31	(3 pin / 1m)
RCA-12SM00-08SF00-32	(3 pin / 2m)

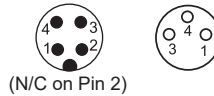

120V AC/DC 4 Amps max.

12MM MALE X 12MM FEMALE

Molded Locking Cable

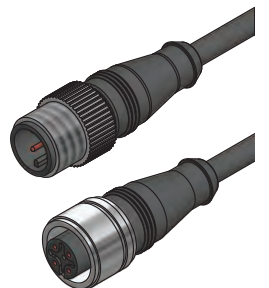
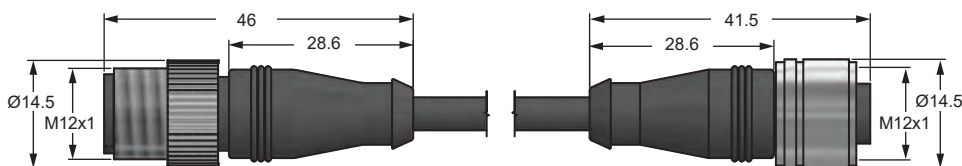

ORDER PART NUMBER

RCA-12SM00-12SF00-41	(4 pin / 1m)
RCA-12SM00-12SF00-42	(4 pin / 2m)



250V AC/DC 4 Amps max.

Round Connectors

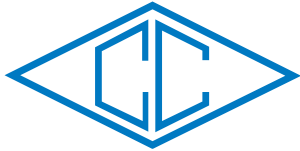

canfield connector
 8510 Foxwood Court
 Youngstown, Ohio 44514
 P:(330) 758-8299 F:(330) 758-8912
 www.canfieldconnector.com

7000 SERIES

**REED AND ELECTRONIC SENSORS FOR
 2" TO 8" BORE TIE ROD CYLINDERS
 OR 3/4" TO 4" ROUND CYLINDERS**

General Description

The Canfield 7000 Series proximity sensors are used to sense position on cylinders. They accommodate 2 to 8 inch bore tie rod cylinders or 3/4 to 4 inch round cylinders. This proven design is rugged yet cost effective. The Series 7000 boasts the largest number of custom circuits to match applications found in the market. Examples include; 1 or 4 Amp reed switches, normally open, normally closed or SPDT switch types, reed or electronic sensing elements in the same package style, and the industry's first 120 VAC Hall sensor. A wide range of enclosures and connector options are available. To reduce stocking requirements, two clamp options feature a self-adjusting clamp for NFPA and other tie rod cylinders from 2 to 8 inch bore. Another clamp option features a band clamp from 3/4 to 4 inch round cylinders.

Dimensional Data

ALL DIMENSIONS ARE IN MILLIMETERS UNLESS OTHERWISE NOTED

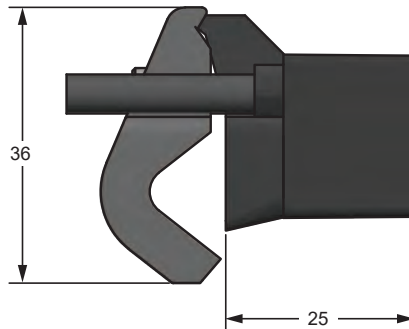
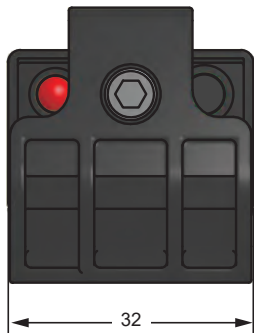

Mounting / Clamp Styles

STYLE: 0

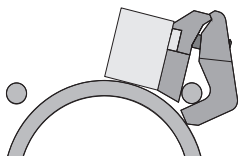

Clamp for NFPA tie-rod cylinders
 Universal 2" to 6" bore.

STYLE: 9

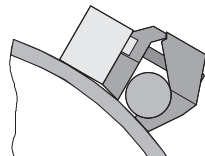

Clamp for NFPA tie-rod cylinders
 6" to 8" bore.

Mating Cordsets / Configuration

12mm female molded locking connectors

(3 pole) 250VAC/DC 4 Amps max.

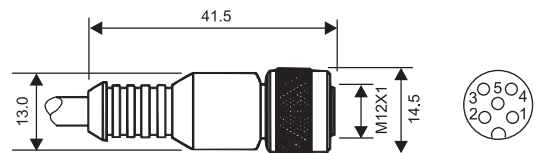

Brown = Pin 1
 Blue = Pin 3
 Black = Pin 4
 N/C = Pin 2
 N/C = Pin 5

Order part number

RC12S-F0M030120 (2m length)
 RC12S-F0M030150 (5m length)



Consult factory for available versions listed by Canadian Standards Association for use with certified electrical equipment.

Technical Data

Switch Type / Tech. Specs.	See Ordering Information [†]
Sensitivity / Orientation	Reed / Electronic: 85 Gauss Parallel (measured from sensor surface)
Shock	Up to 30G (11mS) Reed Only (not applicable for electronics)
Vibration	Up to 20G (10-55 Hz) Reed only
Materials	Cable: PVC House: PEI, PA
Temperature Range	-20° to +80°C
Environmental Protection	Designed for IP 67 / NEMA 6
Cable Diameter	.2mm
Wire Gauge	22 AWG standard

Ordering Information

Mounting / Clamp Style
 0 - Universal tie rod clamp 2" to 6" bore
 9 - 5/8" tie rod clamp 6" to 8" bore

Connector Style
 0 - Standard cable module (9 ft)
 5 - 12mm quick connect male*
 *Mates with cordsets shown on previous page

7 1 0 - [] 0 0 - [] [] []

Switch Type [†]	Description	Function	Switching Voltage	Switching Current	Switching Power	Voltage Drop
01	Reed Switch, 2 Wire	Normally Open SPST	0 - 240V AC/DC 50/60 Hz	1 Amp max.	30 Watts max.	0 Volts
04	Reed Switch, MOV, Red LED, 2 Wire	Normally Open SPST	5 - 240V AC/DC 50/60 Hz	1 Amp max. .005 Amps min.	30 Watts max.	3 Volts
05	Reed Switch, 2 Wire	Normally Closed SPST	0 - 120V AC/DC 50/60 Hz	1 Amp max.	20 Watts max.	0 Volts
06	Reed Switch, Red LED, 3 Wire	Single Pole, Double Throw	5 - 120V AC/DC 50/60 Hz	1 Amp max. .005 Amps min.	20 Watts max.	3 Volts/load1 0 Volts/load2
09	Reed Switch, MOV, Red LED, 2 Wire	Normally Closed SPST	5 - 120V AC/DC 50/60 Hz	1 Amp max. .005 Amps min.	20 Watts max.	3 Volts
15	AC Electronic Sensor for Reed Magnets, Red LED, 3 Wire	Normally Open TRIAC output	12-24 VAC	600 mA max. 5 Amps Inrush	15 Watts max.	1 Volt
16	AC Electronic Sensor for Reed Magnets, Red LED, 3 Wire	Normally Open TRIAC output	120 VAC	600 mA max. 5 Amps Inrush	72 Watts max.	1 Volt
21	Reed Switch, MOV, 2 Wire	Normally Open TRIAC output	10 - 240 VAC 50/60 Hz	4 Amps max. 50 Amps Inrush	100 Watts max.	1 Volt
23	Reed Switch, MOV, Red LED, 3 Wire	Normally Open TRIAC output	10 - 50 VAC 50/60 Hz	4 Amps max. 50 Amps Inrush .005 Amps min.	100 Watts max.	1 Volt
24	Reed Switch, MOV, Red LED, 3 Wire	Normally Open TRIAC output	24 - 240 VAC 50/60 Hz	4 Amps max. 50 Amps Inrush .005 Amps min.	100 Watts max.	1 Volt
25	Reed Switch, MOV, 2 Wire	Normally Closed TRIAC output	10-120 VAC 50/60 Hz	4 Amps max. 50 Amps Inrush	100 Watts max.	1 Volt
29	Reed Switch, MOV, Red LED, 3 Wire	Normally Closed TRIAC Output	10-120 VAC 50/60 Hz	4 Amps max. 50 Amps Inrush .005 Amps min.	100 Watts max.	1 Volts
31	Electronic for Reed Magnet, Red LED & Sourcing, 3 Wire	Normally Open PNP	6 - 24 VDC	1 Amp max.	24 Watts max.	0.5 Volts
32	Electronic for Reed Magnet, Red LED & Sinking, 3 Wire	Normally Open NPN	6 - 24 VDC	1 Amp max.	24 Watts max.	0.5 Volts

Each switch supplied with clamp assembly

For convenience and faster shipping,
this series is available in Can-Paks.



Ordering Example: 710-000-004

Universal tie rod clamp, Standard cable, reed switch, lighted, MOV surge suppression, normally open, 5 - 240V AC/DC 50/60 Hz

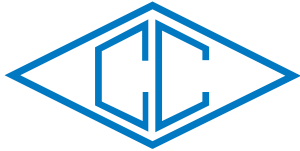

canfield connector
 8510 Foxwood Court
 Youngstown, Ohio 44514
 P:(330) 758-8299 F:(330) 758-8912
 www.canfieldconnector.com

7C SERIES

REED AND ELECTRONIC SENSORS FOR 2" TO 8" BORE TIE ROD CYLINDERS

General Description

The Canfield Connector 7C Series proximity sensors are used to sense position on pneumatic actuators equipped with magnetic pistons from 2" to 8" bore. This proven design is rugged yet cost effective. All switches feature a self-adjusting clamp that grips standard NFPA and custom cylinders eliminating stocking requirements of many clamps for different bore sizes. The Series 7C boasts the largest number of custom circuits to match applications found in the market. Examples include; 1 or 4 Amp reed switches, normally open, normally closed or SPDT switch types, reed or electronic sensing elements in the same package style, not to mention the industry's first 120 VAC Hall sensor. The low cost 7C features a 1/2" conduit hub and wire lead to meet stringent electrical codes in certain regions and applications.

Dimensional Data

ALL DIMENSIONS ARE IN MILLIMETERS UNLESS OTHERWISE NOTED

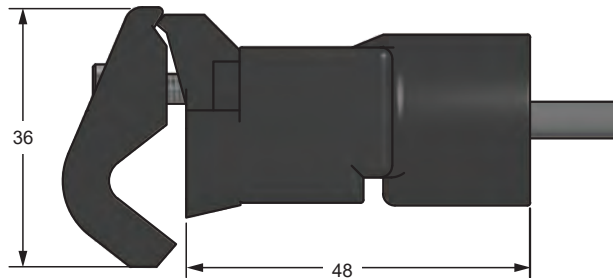
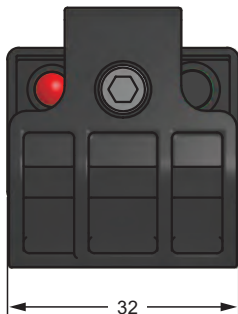
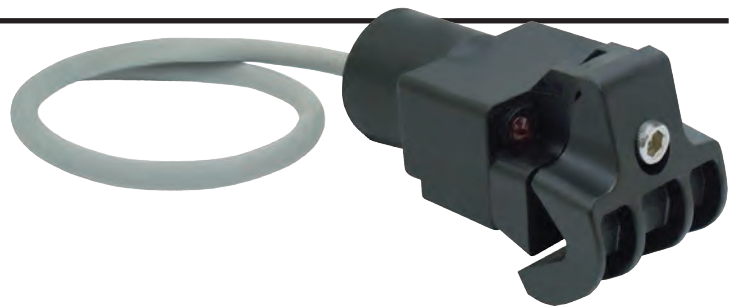

Mounting / Clamp Styles

STYLE: 0

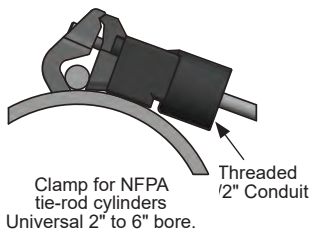

STYLE: 9

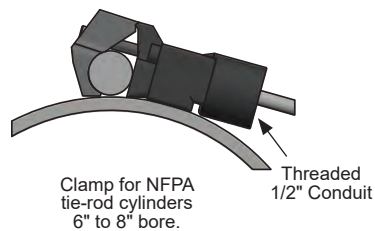

Pin Configuration

STYLE: 3

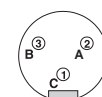

3 Pin
Automotive
Connector

STYLE: 4

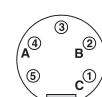

5 Pin
Automotive
Connector

Technical Data

Switch Type / Tech. Specs.	See Ordering Information†
Sensitivity / Orientation	Reed / Electronic: 85 Gauss Parallel (measured from sensor surface)
Shock	Up to 30G (11mS) Reed Only (not applicable for electronics)
Vibration	Up to 20G (10-55 Hz) Reed only
Materials	Cable: PVC House: PEI, PA
Temperature Range	-20° to +80°C
Environmental Protection	Designed for IP 67 / NEMA 6
Cable Diameter	.2mm
Wire Gauge	22 AWG standard

Ordering Information

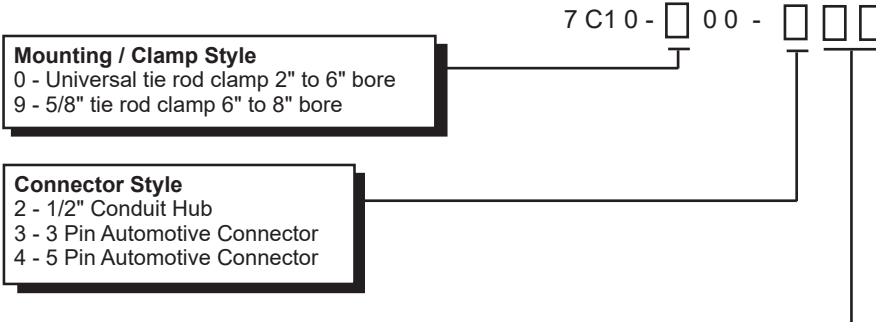

Switch† Type	Description	Function	Switching Voltage	Switching Current	Switching Power	Voltage Drop
01	Reed Switch, 2 Wire	Normally Open SPST	0 - 240V AC/DC 50/60 Hz	1 Amp max.	30 Watts max.	0 Volts
04	Reed Switch, MOV, Red LED, 2 Wire	Normally Open SPST	5 - 240V AC/DC 50/60 Hz	1 Amp max. .005 Amps min.	30 Watts max.	3 Volts
05	Reed Switch, 2 Wire	Normally Closed SPST	0 - 120V AC/DC 50/60 Hz	1 Amp max.	20 Watts max.	0 Volts
06	Reed Switch, Red LED, 3 Wire	Single Pole, Double Throw	5 - 120V AC/DC 50/60 Hz	1 Amp max. .005 Amps min.	20 Watts max.	3Volts/load1 0Volts/load2
09	Reed Switch, MOV, Red LED, 2 Wire	Normally Closed SPST	5 - 120V AC/DC 50/60 Hz	1 Amp max. .005 Amps min.	20 Watts max.	3 Volts
15	AC Electronic Sensor for Reed Magnets, Red LED, 3 Wire	Normally Open TRIAC output	12-24 VAC	600 mA max. 5 Amps Inrush	15 Watts max.	1 Volt
16	AC Electronic Sensor for Reed Magnets, Red LED, 3 Wire	Normally Open TRIAC output	120 VAC	600 mA max. 5 Amps Inrush	72 Watts max.	1 Volt
21	Reed Switch, MOV, 2 Wire	Normally Open TRIAC output	10 - 240 VAC 50/60 Hz	4 Amps max. 50 Amps Inrush	100 Watts max.	1 Volt
23	Reed Switch, MOV, Red LED, 3 Wire	Normally Open TRIAC output	10 - 50 VAC 50/60 Hz	4 Amps max. 50 Amps Inrush .005 Amps min.	100 Watts max.	1 Volt
24	Reed Switch, MOV, Red LED, 3 Wire	Normally Open TRIAC output	24 - 240 VAC 50/60 Hz	4 Amps max. 50 Amps Inrush .005 Amps min.	100 Watts max.	1 Volt
25	Reed Switch, MOV, 2 Wire	Normally Closed TRIAC output	10-120 VAC 50/60 Hz	4 Amps max. 50 Amps Inrush	100 Watts max.	1 Volt
29	Reed Switch, MOV, Red LED, 3 Wire	Normally Closed TRIAC Output	10-120 VAC 50/60 Hz	4 Amps max. 50 Amps Inrush .005 Amps min.	100 Watts max.	1 Volts
31	Electronic for Reed Magnet, Red LED & Sourcing, 3 Wire	Normally Open PNP	6 - 24 VDC	1 Amp max.	24 Watts max.	0.5 Volts
32	Electronic for Reed Magnet, Red LED & Sinking, 3 Wire	Normally Open NPN	6 - 24 VDC	1 Amp max.	24 Watts max.	0.5 Volts

Ordering Example: 7C10-000-204

Universal tie rod clamp, 1/2" conduit hub, reed switch, lighted, MOV surge suppression, normally open, 5 - 240V AC/DC 50/60 Hz

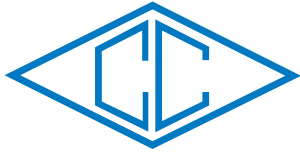

canfield connector
 8510 Foxwood Court
 Youngstown, Ohio 44514
 P:(330) 758-8299 F:(330) 758-8912
 www.canfieldconnector.com

7GL SERIES

GENERAL LOCATION MAGNETIC PROXIMITY SENSORS FOR TIE ROD CYLINDERS

General Description

The Canfield Connector 7GL is an expansion of the popular Series 7000 "floating" clamp design, which adapts to NFPA tie rod linear actuators with 2 to 8 inch bore. This rugged magnetic proximity sensor can sense actuator position in stringent, general location applications. The switch features a robust, aircraft aluminum body, epoxy-filled, vibration and shock resistant, electronic circuit. Available in a normally open contact, the 7GL can switch current up to .5 Amps and has a voltage range of 0-120VAC/VDC 50/60 Hz.

Dimensional Data

ALL DIMENSIONS ARE IN MILLIMETERS UNLESS OTHERWISE NOTED

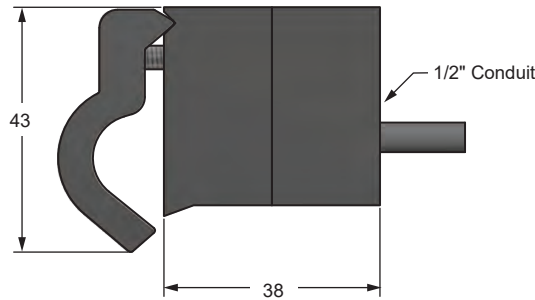
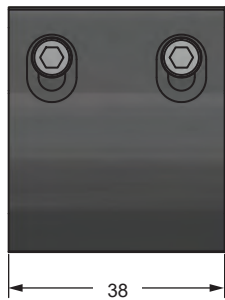

Technical Data

Switch Type	S.P.S.T., Normally Open, Reed
Operating Voltage	0-120 V AC/DC 50/60 Hz
Load Max.	10W, Resistive only
Current Max.	0.5A
Response Time	On: 0.5ms Off: 0.1ms
Sensitivity / Orientation	85 Gauss Parallel (measured from sensor surface)
Shock	Up to 30G (11ms)
Vibration	Up to 20G (10-55 Hz)
Materials	Cable: PVC House: Anodized 6061-T6 Aluminum, Epoxy encapsulated printed circuit board
Temperature Range	-20° to +80°C
Environmental Protection	Designed for NEMA 1, 4 and 13
Cable Diameter	.19mm
Wire Gauge	20 AWG standard
Wire Length	9 Ft. standard

Mounting Installation

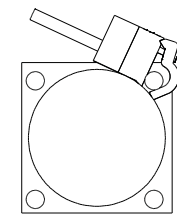

Clamp for NFPA tie-rod cylinders Universal 2" to 6" bore.

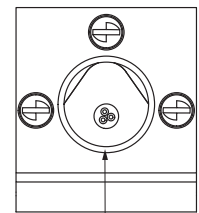

1/2" Conduit

Electrical Installation

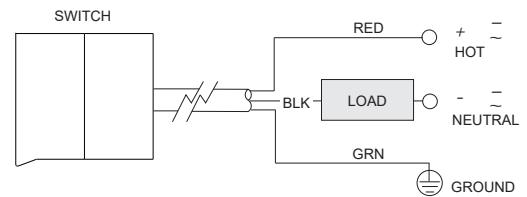

— Both direct and alternating current

⊕ Earth (ground) TERMINAL

Ordering Information

ORDER PART NUMBER
7GL10-000-001

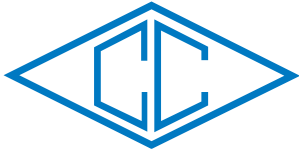

canfield connector
 8510 Foxwood Court
 Youngstown, Ohio 44514
 P:(330) 758-8299 F:(330) 758-8912
 www.canfieldconnector.com

7HL SERIES

HAZARDOUS LOCATION MAGNETIC PROXIMITY SENSORS FOR TIE ROD CYLINDERS

General Description

The Canfield Connector 7HL is a rugged magnetic proximity sensor designed to sense actuator position in stringent, hazardous location applications. The switch features a robust, epoxy-filled, aircraft aluminum body, and has a vibration and shock resistant, electronic circuit. The 7HL is an expansion of the popular Series 7000 "floating" clamp design and will clamp on 2 to 8 inch bore NFPA tie rod linear actuators. This product is designed to operate in hazardous locations, this switch is CSA approved for Class I, Division 2, Groups A, B, C, and D; Class II, Division 2, Groups F and G; and Class III.

Dimensional Data

ALL DIMENSIONS ARE IN MILLIMETERS UNLESS OTHERWISE NOTED

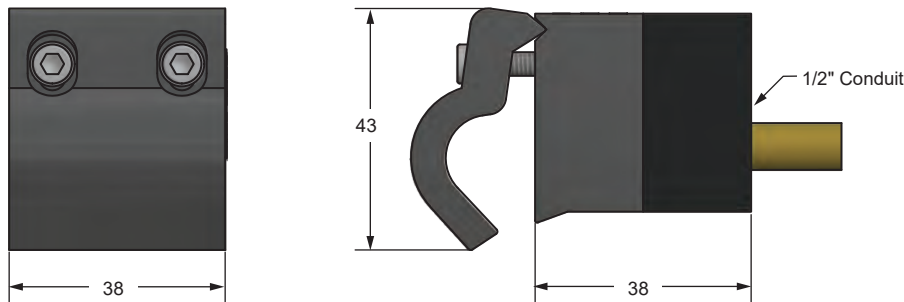

Sensors

Technical Data

Switch Type	S.P.S.T., Normally Open, Reed
Operating Voltage	0-120 V AC/DC 50/60 Hz
Load Max.	10W, Resistive only
Current Max.	0.5A
Response Time	On: 0.5ms Off: 0.1ms
Sensitivity / Orientation	85 Gauss Parallel (measured from sensor surface)
Shock	Up to 30G (11ms)
Vibration	Up to 20G (10-55 Hz)
Materials	Cable: PVC House: Anodized 6061-T6 Aluminum, Epoxy encapsulated printed circuit board
Temperature Range	-20° to +80°C
Environmental Protection	Designed for NEMA 1, 4 and 13
Hazardous location rating	CSA: Class I, Division 2, Groups A, B, C and D; Class II, Division 2, Groups F and G; and Class III
Cable Diameter	.310mm
Wire Gauge	SJTOW type, 18 AWG standard
Wire Length	9 Ft. standard

Mounting Installation

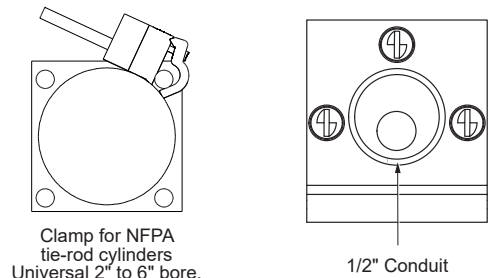

Electrical Installation

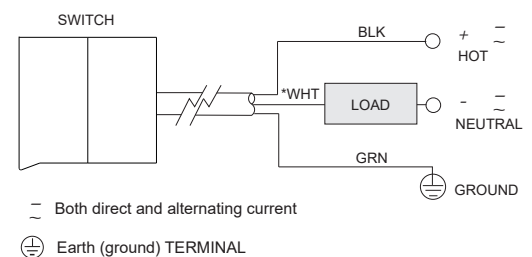

*White wire must be permanently reidentified to indicate its use as an ungrounded conductor, by painting or other effective means at its termination, and each location where the conductor is visible and accessible. Per NEC Article (200.7)

Ordering Information

ORDER PART NUMBER
7HL10-000-001



Consult factory for available versions listed by Canadian Standards Association for use with certified electrical equipment.

A56-1377 Rev.04

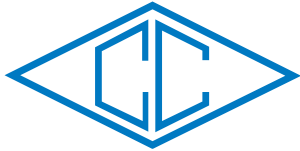

canfield connector
 8510 Foxwood Court
 Youngstown, Ohio 44514
 P:(330) 758-8299 F:(330) 758-8912
 www.canfieldconnector.com

8000 SERIES

REED & ELECTRONIC SENSORS FOR ROUND, TIE-ROD, OR EXTRUDED CYLINDERS

General Description

The Canfield Connector 8000 Series Reed and Electronic sensors are compact units designed for sensing applications on round cylinders from 9/16" - 4" and tie-rod pneumatic cylinders from 3/4" - 8" bore. These sensors offer a wide voltage range from 0-120 VAC/VDC 50/60 Hz and high current capacity up to 0.5 Amps. They include high intensity indicator lights and a wide viewing angle. The sensor's small package can fit easily on the smallest cylinder without appearing too large. The Series 8000's design promotes ease of installation with a tight fit. Options include 9ft. PVC or 8mm quick connect male pigtail.

Dimensional Data

ALL DIMENSIONS ARE IN MILLIMETERS UNLESS OTHERWISE NOTED

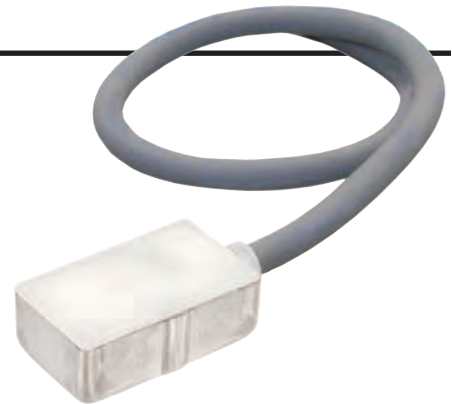
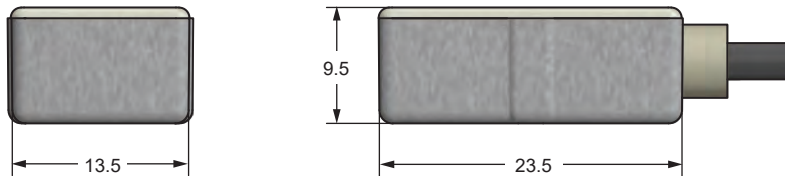

Mounting / Clamp Styles

STYLE: 0

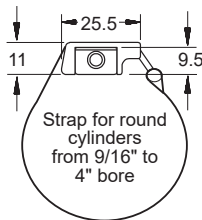

STYLE: 2

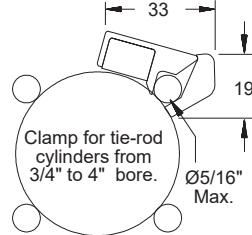

STYLE: 3

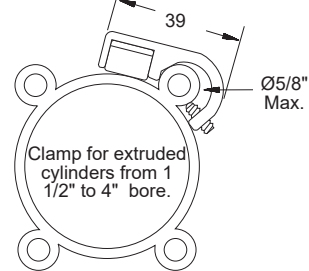

STYLE: 5-9

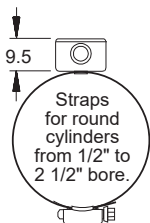

STYLE: A

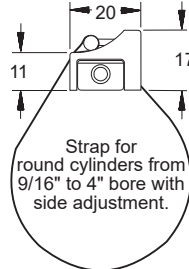

STYLE: B

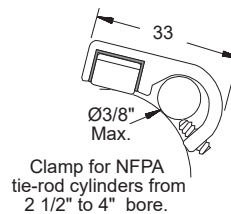

STYLE: C

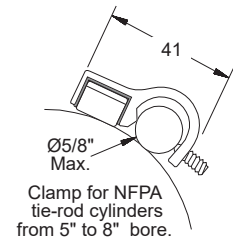

Consult factory for available versions listed by Canadian Standards Association for use with certified electrical equipment.

Technical Data

Switch Type / Tech. Specs.	See Ordering Information†
Sensitivity / Orientation	Reed / Electronic: 85 Gauss Parallel (measured from sensor surface)
Shock	Up to 30G (11mS) Reed Only (not applicable for electronics)
Vibration	Up to 20G (10-55 Hz) Reed only
Materials	Cable: PVC House: PA
Temperature Range	-20° to +80°C
Environmental Protection	Designed for IP 65 / NEMA 4, IP 67 / NEMA 6 available on request
Cable Diameter	3.7mm
Wire Gauge	24 AWG standard

Mating Cordsets / Pin Configuration

8mm female molded locking connectors

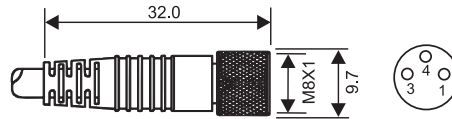

Order part number

Brown = Pin 1
Blue = Pin 3
Black = Pin 4

RC08S-F0M030120 (2m length)
RC08S-F0M030150 (5m length)

Ordering Information

Mounting / Clamp Styles

0 - Universal round cylinder clamp
1 - No clamp
2 - Universal tie-rod clamp
3 - Extruded cylinder clamp
5 - Clamp loop / no clamp***
6 - Clamp loop / 1/2" - 3/4" clamp
7 - Clamp loop / 1" - 1 1/2" clamp
8 - Clamp loop / 1 1/2" - 2" clamp
9 - Clamp loop / 2" - 2 1/2" clamp
A - Side adjust round cylinder clamp
B - NFPA 2 1/2" - 4" tie-rod cylinder clamp
C - NFPA 5" - 8" tie-rod cylinder clamp
***Uses 5/16" wide band clamp

Connection Options

0 - 9 ft PVC cable
1 - 8mm quick connect male pigtail*
*Mates with cordsets shown above

8 1 0 - 0 0 -

Switch† Type	Description	Function	Switching Voltage	Switching Current	Switching Power	Voltage Drop	Magnetic Sensitivity
01	Reed Switch	Normally Open SPST	0 - 120V AC/DC	0.5 Amps Max.	10 watts Max.	0 Volts	85 Ga.
02	Reed Switch & Red LED	Normally Open SPST	5 - 120V AC/DC	0.025 Amps Max. 0.001 Amps Min.	3 watts Max.	6.0 Volts	85 Ga.
04	Reed Switch, Red LED & MOV	Normally Open SPST	5 - 120V AC/DC	0.5 Amps Max. 0.005 Amps Min.	10 watts Max.	3.0 Volts	85 Ga.
31	Electronic for Reed Magnet, Red LED & Sourcing	Normally Open PNP	6 - 24 VDC	0.3 Amps Max.	7.2 watts Max.	.5 Volts	85 Ga.
32	Electronic for Reed Magnet, Red LED & Sinking	Normally Open NPN	6 - 24 VDC	0.3 Amps Max.	7.2 watts Max.	.5 Volts	85 Ga.

Ordering Example: 810-000-002

Universal round cylinder clamp, 9ft PVC cable, reed switch with LED, SPST, normally open, 5 - 120V AC/DC

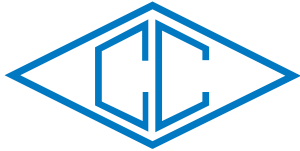

canfield connector
8510 Foxwood Court
Youngstown, Ohio 44514
P:(330) 758-8299 F:(330) 758-8912
www.canfieldconnector.com

8WS SERIES

REED & ELECTRONIC SENSORS FOR PNEUMATIC CYLINDERS WITH 12MM DOVETAIL

General Description

The Canfield Connector 8WS Series reed and electronic magnet sensors are rugged yet compact switches used to sense position on pneumatic actuators equipped with a magnetic piston and 12mm dovetail groove. The switch can be slipped in and tightened from anywhere along the groove that is fabricated into the cylinder wall or clamping system. The switch features a die cast holder which clamps to the cylinder groove while the electronics are fully encapsulated and resistance to environment. These sensors offer a wide voltage range from 0-120 V AC/DC 50/60Hz and have a up to a 500 mA switching current rating. The switch has a high intensity indicator light which indicates power to the switch and load. Options include 9ft. PVC or 8mm quick connect male pigtail.

Dimensional Data

ALL DIMENSIONS ARE IN MILLIMETERS UNLESS OTHERWISE NOTED

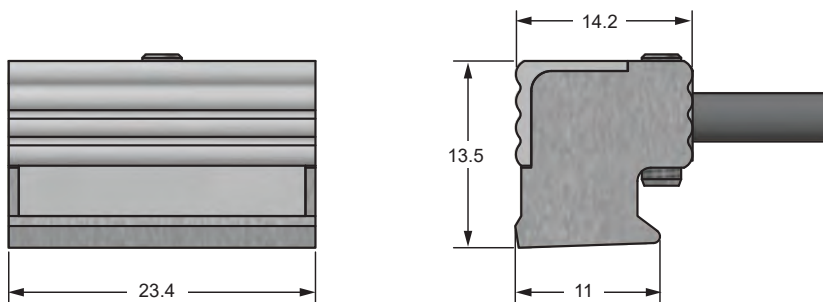
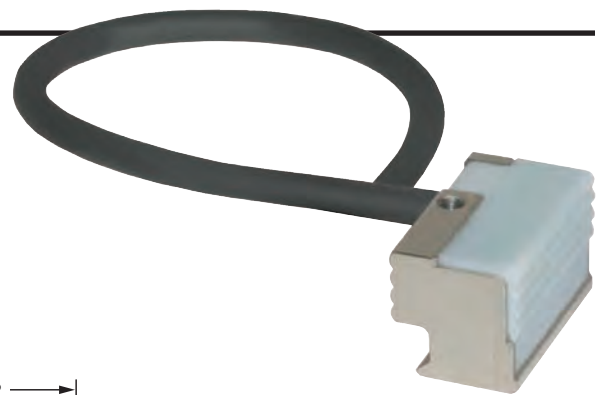

Groove Details

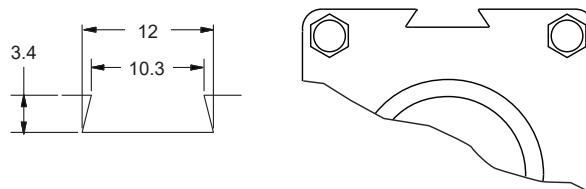

(Fits: Numatics)



Consult factory for available versions listed by Canadian Standards Association for use with certified electrical equipment.

A56-1358 Rev.03

Technical Data

Switch Type / Tech. Specs.	See Ordering Information [†]
Sensitivity / Orientation	Reed / Electronic: 85 Gauss Parallel (measured from sensor surface)
Shock	Up to 30G (11mS) Reed Only (not applicable for electronics)
Vibration	Up to 20G (10-55 Hz) Reed only
Materials	Cable: PVC House: PA
Temperature Range	-20° to +80°C
Environmental Protection	Designed for IP 67 / NEMA 6
Cable Diameter	3.7mm
Wire Gauge	24 AWG standard

Mating Cordsets / Pin Configuration

8mm female molded locking connectors

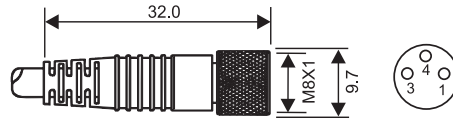

(for sensor types 01, 02, 04, 31, 32)

Order part number

Brown = Pin 1 RC08S-F0M030120 (2m length)
 Blue = Pin 3 RC08S-F0M030150 (5m length)
 Black = Pin 4

Ordering Information

8 W S 1 0 - 0 0 0 -

Connection Options

0 - 9 ft PVC cable
 1 - 8mm quick connect male pigtail*
 *Mates with cordsets shown above

Switch [†] Type	Description	Function	Switching Voltage	Switching Current	Switching Power	Voltage Drop	** Magnetic Sensitivity
01	Reed Switch	Normally Open SPST	0 - 120V AC/DC	0.5 Amps Max.	10 watts Max.	0 Volts	85 Ga.
02	Reed Switch & Red LED	Normally Open SPST	5 - 120V AC/DC	0.025 Amps Max. 0.001 Amps Min.	3 watts Max.	6.0 Volts	85 Ga.
04	Reed Switch, Red LED & MOV	Normally Open SPST	5 - 120V AC/DC	0.5 Amps Max. 0.005 Amps Min.	10 watts Max.	3.0 Volts	85 Ga.
31	Electronic for Reed Magnet, Red LED & Sourcing	Normally Open PNP	6 - 24 VDC	0.3 Amps Max.	7.2 watts Max.	.5 Volts	85 Ga.
32	Electronic for Reed Magnet, Red LED & Sinking	Normally Open NPN	6 - 24 VDC	0.3 Amps Max.	7.2 watts Max.	.5 Volts	85 Ga.

^{††}Minimum gauss rating required for proper operation; as measured 4.5 above sensing surface. Size of sensing area depends upon size and strength of magnet and thickness of cylinder wall.

Ordering Example: 8WS10-000-002

9 ft. PVC cable, reed switch with LED, SPST normally open, 5 - 120V AC/DC

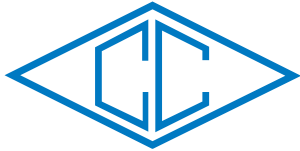

canfield connector
8510 Foxwood Court
Youngstown, Ohio 44514
P:(330) 758-8299 F:(330) 758-8912
www.canfieldconnector.com

9C SERIES

REED & ELECTRONIC MAGNETIC SENSORS FOR ROUND KEYWAY GROOVE

General Description

The 9C Series is a compact, universal, magnetically operated proximity switch commonly used on aluminum extruded profile type linear actuators equipped with magnetic pistons. The switches are available in both reed and electronic styles and made to fit into a 4mm key hole type slot. Position fixing is accomplished by means of a screw that is supplied in the switch body. The on board indicator light shows instant switch diagnostics to minimize downtime and facilitate installation and can be seen from wide angles. Available in the standard 9 ft. PVC wired or optional 8mm quick connect, the switch can handle AC or DC current in several configurations. The 9C is constructed of engineered polymers and designed to meet IP 67 / NEMA 6 environmental specifications.

Dimensional Data

ALL DIMENSIONS ARE IN MILLIMETERS UNLESS OTHERWISE NOTED

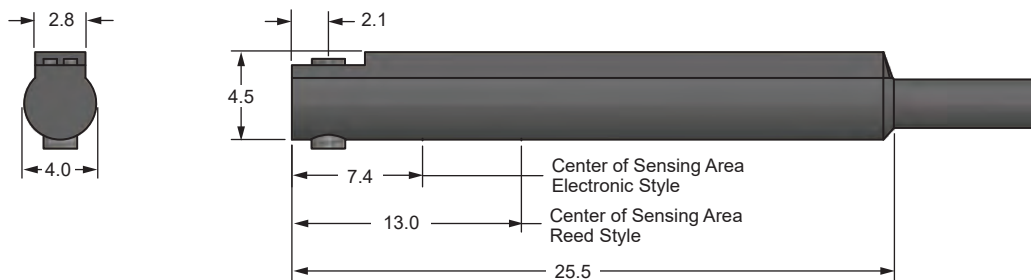

Groove Details

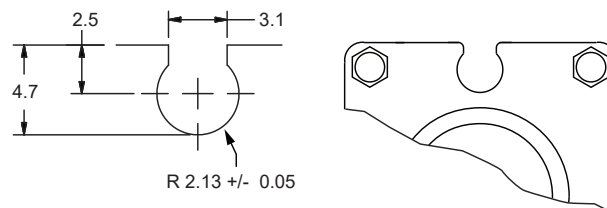

(Fits: DE-STA-CO, Robohand, SMC, Bimba, Compact Air, Fabco)

Technical Data

Switch Type / Tech. Specs.	See Ordering Information†
Sensitivity / Orientation	Electronic: 40 Gauss Parallel Reed: 60 Gauss Parallel (measured from sensor surface)
Shock	Up to 30G (11mS) Reed Only (not applicable for electronics)
Vibration	Up to 20G (10-55 Hz) Reed only
Materials	Cable: PVC House: PEI, Epoxy
Temperature Range	-10° to +70°C
Environmental Protection	Designed for IP 67 / NEMA 6
Cable Diameter	2.8mm
Wire Gauge	26 AWG standard

Mating Cordsets / Pin Configuration

8mm female molded locking connectors

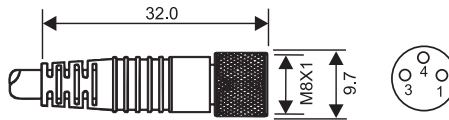

Order part number

Brown = Pin 1
Blue = Pin 3
Black = Pin 4

RC08S-F0M030120 (2m length)
RC08S-F0M030150 (5m length)

Ordering Information

9 C 1 0 - 0 0 0 - [] [] []

Connection Options

0 - 9 ft PVC cable
3 - 8mm quick connect male pigtail*
*Mates with cordsets shown above

Switch Type†	Description	Function	Switching Voltage	Switching Current	Switching Power	Voltage Drop	**Magnetic Sensitivity
02	Reed Switch for PLC's Red LED (current limiting)	Normally Open SPST	5 - 120V AC/DC 50/60 Hz	0.1 Amps Max.	10 watts Max.	2.5 Volts @ 40mA	60 Ga.
31	Electronic for Reed Magnet, Grn LED & Sourcing	Normally Open PNP	5 - 28 VDC	0.2 Amps Max.	6 watts Max.	.5 Volts @ 200mA	40 Ga.
32	Electronic for Reed Magnet, Red LED & Sinking	Normally Open NPN	5 - 28 VDC	0.2 Amps Max.	6 watts Max.	.5 Volts @ 200mA	40 Ga.

†Minimum gauss rating required for proper operation. Size of sensing area depends upon size and strength of magnet and thickness of cylinder wall.

Ordering Example: 9C10-000-032

9 ft. PVC cable, electronic for reed magnet, Red LED, sinking, NPN, 5 - 28 VDC

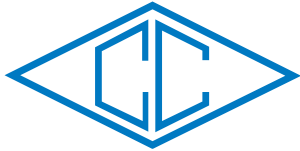

canfield connector
 8510 Foxwood Court
 Youngstown, Ohio 44514
 P:(330) 758-8299 F:(330) 758-8912
 www.canfieldconnector.com

9D SERIES

REED & ELECTRONIC SENSORS
 FOR UNIVERSAL APPLICATIONS

General Description

The Canfield Connector 9D Series is a universal, ultra-small, magnetic proximity switch available in both solid state electronic and reed styles. These sensors are designed to fit the most stringent space requirements by use of a standard .250 inch dovetail slot. Many other mounting options are also available. The electronic sensor exhibits greater sensitivity to magnetism with reduced dead-band and hysteresis as compared to competitive devices. The reed sensor offers a wide operating voltage range. The molded switch has an on board indicator light that can be viewed from wide angles. Standard connection to the sensor is provided by a 9 ft. PVC or 8mm quick connect male pigtail. The rugged switch is shipped with mounting hardware ready for installation.

Dimensional Data

ALL DIMENSIONS ARE IN MILLIMETERS UNLESS OTHERWISE NOTED

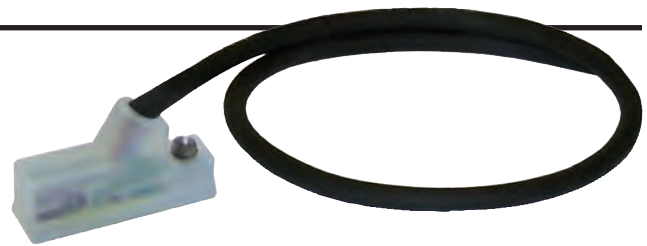
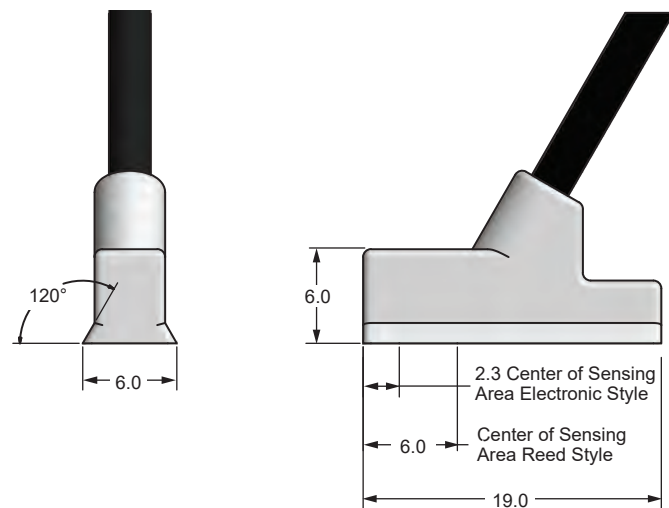

Groove Details

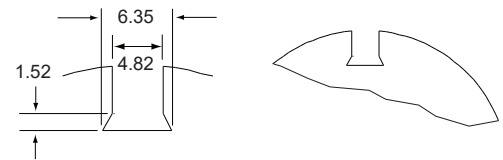

(Fits: Fabco, Numatics, Rotomation)

Mounting / Clamp Styles

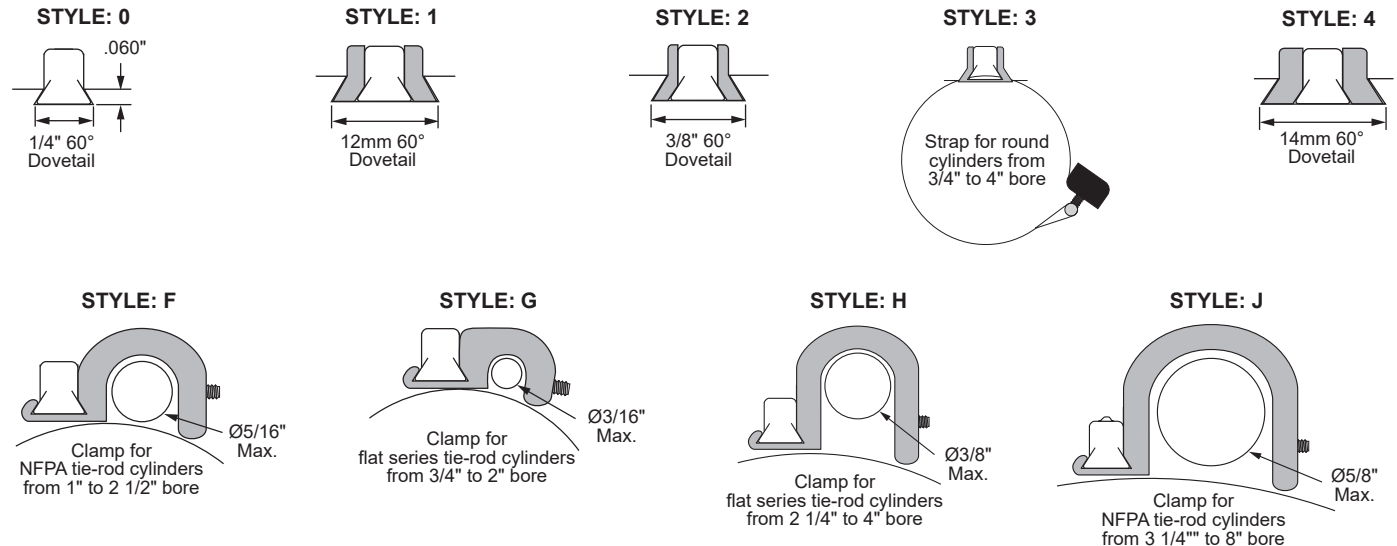

Sensors

Technical Data

Switch Type / Tech. Specs.	See Ordering Information†
Sensitivity / Orientation	Electronic: 25 Gauss Parallel Reed: 85 Gauss Parallel (measured from sensor surface)
Shock	Up to 30G (11mS) Reed Only (not applicable for electronics)
Vibration	Up to 20G (10-55 Hz) Reed only
Materials	Cable: PVC House: PA, TPU
Temperature Range	-20° to +80°C
Environmental Protection	Designed for IP 67 / NEMA 6
Cable Diameter	2.7mm
Wire Gauge	26 AWG standard

Mating Cordsets / Pin Configuration

8mm female molded locking connectors

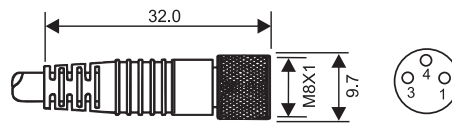

Brown = Pin 1
Blue = Pin 3
Black = Pin 4

Order part number
RC08S-F0M030120 (2m length)
RC08S-F0M030150 (5m length)

Ordering Information

Mounting / Clamp Styles

- 0 - 1/4" 60° dovetail (standard)
- 1 - 12mm 60° dovetail adapter
- 2 - 3/8" 60° dovetail adapter
- 3 - Round cylinder clamp 3/4" - 4" bore
- 4 - 14mm 60° dovetail adapter
- F - NFPA tie-rod cylinder clamp 1" - 2 1/2" bore
- G - Flat series cylinder clamp 3/4" - 2" bore
- H - Flat series cylinder clamp 2 1/4" - 4" bore
- J - NFPA tie-rod cylinder clamp 3 1/4" - 8" bore

Connection Options

- 0 - 9 ft PVC cable
 - 3 - 8mm quick connect male pigtail*
- *Mates with cordsets shown above

9 D 1 0 - [] 0 0 - [] [] []

Switch Type†	Description	Function	Switching Voltage	Switching Current	Switching Power	Voltage Drop	Magnetic Sensitivity
01	Reed Switch	Normally Open SPST	0 - 120V AC/DC 50/60 Hz	0.25 Amps Max.	5 watts Max.	0 Volts	85 Ga.
02	Reed Switch for PLC's, Red LED (current limiting)	Normally Open SPST	5 - 120V AC/DC 50/60 Hz	0.03 Amps Max. 0.001 Amps Min.	4 watts Max.	3.5 Volts @ 5mA	85 Ga.
31	Electronic for Reed Magnet, Yel LED & Sourcing	Normally Open PNP	5 - 28 VDC	0.2 Amps Max.	4.8 watts Max.	1.0 Volts	25 Ga.
32	Electronic for Reed Magnet, Red LED & Sinking	Normally Open NPN	5 - 28 VDC	0.2 Amps Max.	4.8 watts Max.	1.0 Volts	25 Ga.

Ordering Example: 9D10-000-002

1/4" dovetail, 9 ft. PVC cable, reed switch for PLC's with LED, SPST, normally open, 5 - 120V AC/DC 50/60 Hz

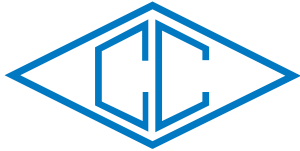

canfield connector
 8510 Foxwood Court
 Youngstown, Ohio 44514
 P:(330) 758-8299 F:(330) 758-8912
 www.canfieldconnector.com

9E SERIES

REED & ELECTRONIC SENSORS
 FOR UNIVERSAL APPLICATIONS

General Description

The Canfield Connector 9E Series is a universal, ultra-small, magnetic proximity switch available in both solid state electronic and reed styles. These sensors are designed to fit the most stringent space requirements by use of a standard .250 inch dovetail slot. Many other mounting options are also available. The electronic sensor exhibits greater sensitivity to magnetism with reduced dead-band and hysteresis as compared to competitive devices. The reed sensor offers a wide operating voltage range. The molded switch has an on board indicator light that can be viewed from wide angles. Standard connection to the sensor is provided by a 9 ft. PVC or 8mm quick connect male pigtail. The rugged switch is shipped with mounting hardware ready for installation.

Dimensional Data

ALL DIMENSIONS ARE IN MILLIMETERS UNLESS OTHERWISE NOTED

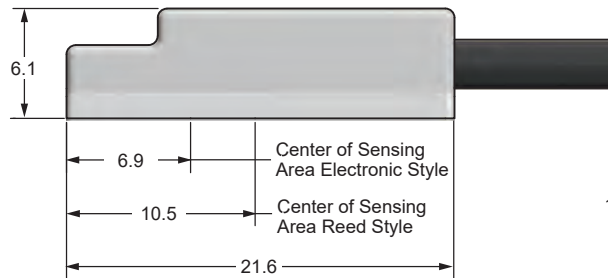
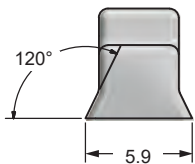

Groove Details

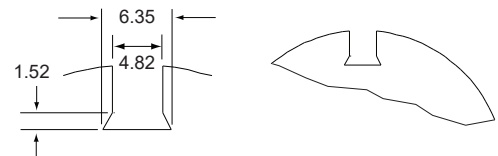

(Fits: Fabco, Numatics, Rotomation)

Mounting / Clamp Styles

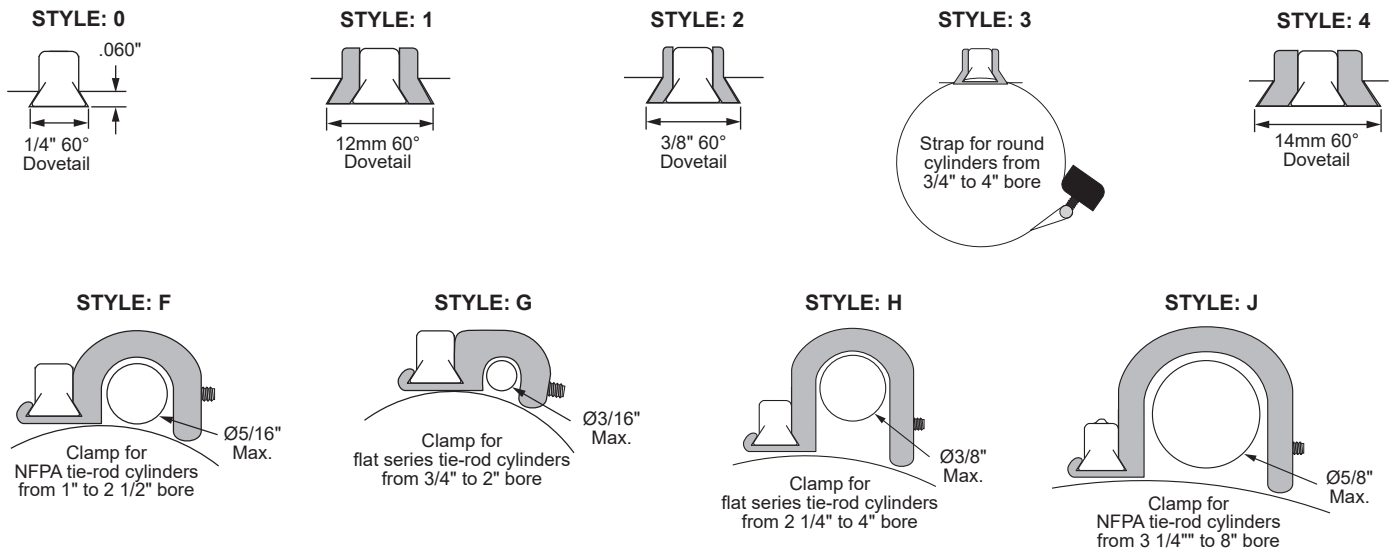

Technical Data

Switch Type / Tech. Specs.	See Ordering Information†
Sensitivity / Orientation	Electronic: 25 Gauss Parallel Reed: 85 Gauss Parallel (measured from sensor surface)
Shock	Up to 30G (11mS) Reed Only (not applicable for electronics)
Vibration	Up to 20G (10-55 Hz) Reed only
Materials	Cable: PVC House: PA, TPU
Temperature Range	-20° to +80°C
Environmental Protection	Designed for IP 67 / NEMA 6
Cable Diameter	2.7mm
Wire Gauge	26 AWG standard

Mating Cordsets / Pin Configuration

8mm female molded locking connectors

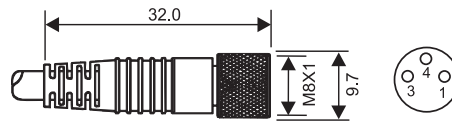

Brown = Pin 1
Blue = Pin 3
Black = Pin 4

Order part number

RC08S-F0M030120 (2m length)
RC08S-F0M030150 (5m length)

Ordering Information

Mounting / Clamp Styles

- 0 - 1/4" 60° dovetail (standard)
- 1 - 12mm 60° dovetail adapter
- 2 - 3/8" 60° dovetail adapter
- 3 - Round cylinder clamp 3/4" - 4" bore
- 4 - 14mm 60° dovetail adapter
- F - NFPA tie-rod cylinder clamp 1" - 2 1/2" bore
- G - Flat series cylinder clamp 3/4" - 2" bore
- H - Flat series cylinder clamp 2 1/4" - 4" bore
- J - NFPA tie-rod cylinder clamp 3 1/4" - 8" bore

Connection Options

- 0 - 9 ft PVC cable
 - 3 - 8mm quick connect male pigtail*
- *Mates with cordsets shown above

9 E 10 - □ 0 0 - □ □ □

Switch† Type	Description	Function	Switching Voltage	Switching Current	Switching Power	Voltage Drop	Magnetic Sensitivity
01	Reed Switch	Normally Open SPST	0 - 120V AC/DC 50/60 Hz	0.25 Amps Max.	5 watts Max.	0 Volts	85 Ga.
02	Reed Switch for PLC's, Red LED (current limiting)	Normally Open SPST	5 - 120V AC/DC 50/60 Hz	0.03 Amps Max. 0.001 Amps Min.	4 watts Max.	3.5 Volts @ 5mA	85 Ga.
31	Electronic for Reed Magnet, Yel LED & Sourcing	Normally Open PNP	5 - 28 VDC	0.2 Amps Max.	4.8 watts Max.	1.0 Volts	25 Ga.
32	Electronic for Reed Magnet, Red LED & Sinking	Normally Open NPN	5 - 28 VDC	0.2 Amps Max.	4.8 watts Max.	1.0 Volts	25 Ga.

Ordering Example: 9E10-000-002

1/4" dovetail, 9 ft. PVC cable, reed switch for PLC's with LED, SPST, normally open, 5 - 120V AC/DC 50/60 Hz

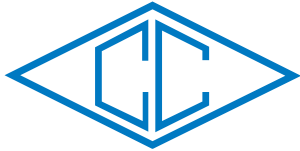

canfield connector
8510 Foxwood Court
Youngstown, Ohio 44514
P:(330) 758-8299 F:(330) 758-8912
www.canfieldconnector.com

9F SERIES

REED & ELECTRONIC SENSORS
FOR 4mm "T" SLOT

General Description

The Canfield Connector 9F Series is a universal, ultra-small, magnetic proximity switch available in both solid state electronic and reed styles. These sensors are designed to fit the most stringent space requirements by using a 4mm "T" slot. The electronic sensor exhibits greater sensitivity to magnetism with reduced dead-band and hysteresis as compared to competitive devices. The reed sensor offers a wide operating voltage range. The molded switch has an on board indicator light that can be viewed from wide angles. Standard connection to the sensor is provided by a 9 ft. PVC or 8mm quick connect male pigtail. The rugged switch is shipped with mounting hardware ready for installation.

Dimensional Data

ALL DIMENSIONS ARE IN MILLIMETERS UNLESS OTHERWISE NOTED

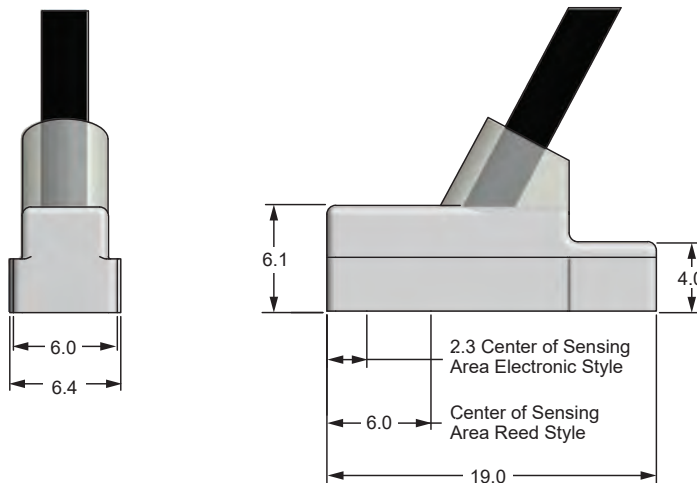
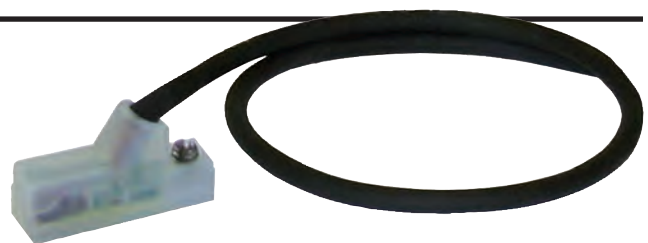

Groove Details

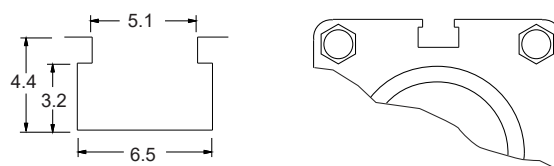

(Fits: Fabco, Festo, Numatics, Rotomation)

Technical Data

Switch Type / Tech. Specs.	See Ordering Information [†]
Sensitivity / Orientation	Electronic: 25 Gauss Parallel Reed: 85 Gauss Parallel (measured from sensor surface)
Shock	Up to 30G (11mS) Reed Only (not applicable for electronics)
Vibration	Up to 20G (10-55 Hz) Reed only
Materials	Cable: PVC House: PA, TPU
Temperature Range	-20° to +80°C
Environmental Protection	Designed for IP 67 / NEMA 6
Cable Diameter	2.7mm
Wire Gauge	26 AWG standard

Mating Cordsets / Pin Configuration

8mm female molded locking connectors

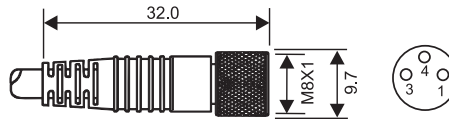

Brown = Pin 1
Blue = Pin 3
Black = Pin 4

Order part number
RC08S-F0M030120 (2m length)
RC08S-F0M030150 (5m length)

Ordering Information

9 F 1 0 - 0 0 0 - □ □ □

Connection Options

0 - 9 ft PVC cable
3 - 8mm quick connect male pigtail*
**Mates with cordsets shown above*

Switch [†] Type	Description	Function	Switching Voltage	Switching Current	Switching Power	Voltage Drop	Magnetic Sensitivity
01	Reed Switch	Normally Open SPST	0 - 120V AC/DC 50/60 Hz	0.25 Amps Max.	5 watts Max.	0 Volts	85 Ga.
02	Reed Switch for PLC's, Red LED (current limiting)	Normally Open SPST	5 - 120V AC/DC 50/60 Hz	0.03 Amps Max. 0.001 Amps Min.	4 watts Max.	3.5 Volts @ 5mA	85 Ga.
31	Electronic for Reed Magnet, Yel LED & Sourcing	Normally Open PNP	5 - 28 VDC	0.2 Amps Max.	4.8 watts Max.	1.0 Volts	25 Ga.
32	Electronic for Reed Magnet, Red LED & Sinking	Normally Open NPN	5 - 28 VDC	0.2 Amps Max.	4.8 watts Max.	1.0 Volts	25 Ga.

Ordering Example: 9F10-000-002

9 ft. PVC cable, reed switch for PLC's with LED, SPST, normally open, 5 - 120V AC/DC 50/60 Hz

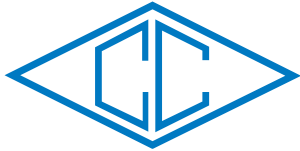

canfield connector
8510 Foxwood Court
Youngstown, Ohio 44514
P:(330) 758-8299 F:(330) 758-8912
www.canfieldconnector.com

9G SERIES

REED & ELECTRONIC SENSORS
FOR 6.3MM "T" SLOT APPLICATIONS

General Description

The Canfield Connector 9G Series linear magnetic position sensor is designed to work with aluminum extrusion type actuators that have a 6.2mm X 4.4mm rectangular groove designed into the body. Available in reed or electronic versions, the 9G fits into commonly used sensor grooves. Standard connection to the sensor is provided by a 9 ft. PVC or 8mm quick connect male pigtail. The switch is water resistant and dust tight to IP-67.

Dimensional Data

ALL DIMENSIONS ARE IN MILLIMETERS UNLESS OTHERWISE NOTED

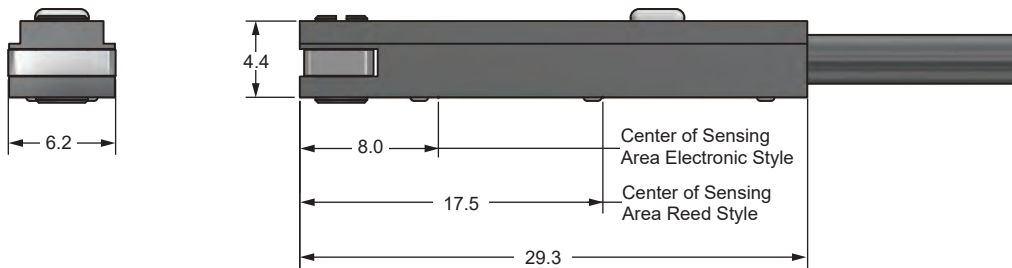

Groove Details

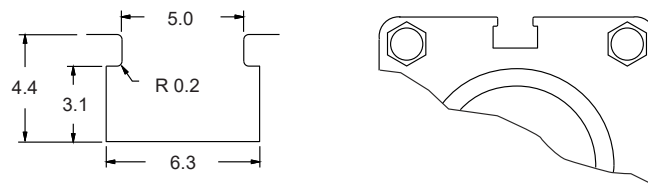

(Fits: Fabco, Numatics, Rotomation)

Technical Data

Switch Type / Tech. Specs.	See Ordering Information [†]
Sensitivity / Orientation	Electronic: 25 Gauss Parallel Reed: 85 Gauss Parallel (measured from sensor surface)
Shock	Up to 30G (11mS) Reed Only (not applicable for electronics)
Vibration	Up to 20G (10-55 Hz) Reed only
Materials	Cable: PVC House: PBT
Temperature Range	-20° to +80°C
Environmental Protection	Designed for IP 67 / NEMA 6
Cable Diameter	2.8mm
Wire Gauge	26 AWG standard

Mating Cordsets / Pin Configuration

8mm female molded locking connectors

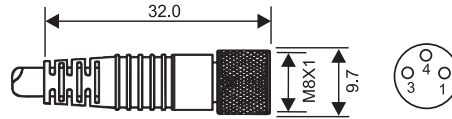

Brown = Pin 1
Blue = Pin 3
Black = Pin 4

Order part number

RC08S-F0M030120 (2m length)
RC08S-F0M030150 (5m length)

Ordering Information

9 G 1 0 - 0 0 0 - □ □ □

Connection Options

0 - 9 ft PVC cable
3 - 8mm quick connect male pigtail*
**Mates with cordsets shown above*

Switch [†] Type	Description	Function	Switching Voltage	Switching Current	Switching Power	Voltage Drop	Magnetic Sensitivity
02	Reed Switch with Red LED	Normally Open SPST	5-240V AC/DC	0.1 Amps Max.	10 watts Max.	2.5 Volts @ 100 mA DC	40 Ga.
31	Electronic for Reed Magnet, with Grn LED & Sourcing	Normally Open PNP	5-28 VDC	0.2 Amps Max.	6 watts Max.	1.5 Volts @ 200 mA	60 Ga.
32	Electronic for Reed Magnet, with Red LED & Sinking	Normally Open NPN	5-28 VDC	0.2 Amps Max.	6 watts Max.	1.5 Volts @ 200 mA	60 Ga.

Ordering Example: 9G10-000-002

9 ft. PVC cable, reed switch with red LED, SPST, 5 - 240V AC/DC 50/60 Hz

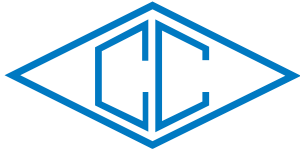

canfield connector
8510 Foxwood Court
Youngstown, Ohio 44514
P:(330) 758-8299 F:(330) 758-8912
www.canfieldconnector.com

9H SERIES

REED & ELECTRONIC MAGNETIC SENSORS
FOR 4.2MM "T" SLOT APPLICATIONS

General Description

The Canfield Connector 9H Series is a profile mounting type switch that fits in a 4mm X 4mm square groove which normally is designed into an aluminum extrusion type linear actuator. Available in reed or electronic versions, the 9H is also available with a 9 ft. PVC or 8mm quick connect male pigtail. The switch is IP-67 which is dust tight and water resistant.

Dimensional Data

ALL DIMENSIONS ARE IN MILLIMETERS UNLESS OTHERWISE NOTED

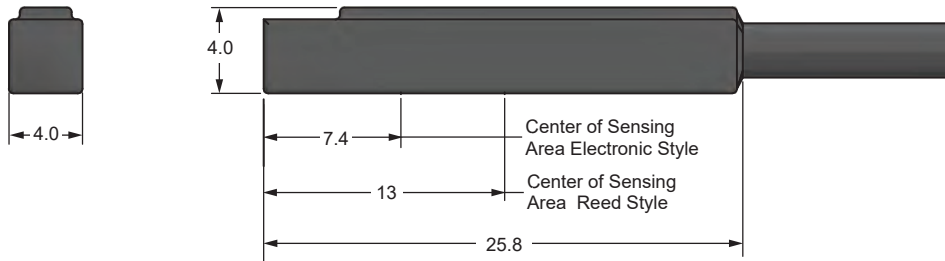

Groove Details

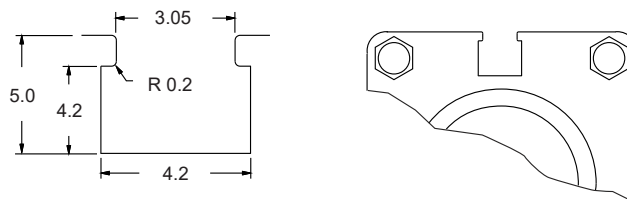

(Fits: 4x4 groove)

Sensors

Technical Data

Switch Type / Tech. Specs.	See Ordering Information [†]
Sensitivity / Orientation	Electronic: 25 Gauss Parallel Reed: 85 Gauss Parallel (measured from sensor surface)
Shock	Up to 30G (11mS) Reed Only (not applicable for electronics)
Vibration	Up to 20G (10-55 Hz) Reed only
Materials	Cable: PVC House: ABS
Temperature Range	-20° to +80°C
Environmental Protection	Designed for IP 67 / NEMA 6
Cable Diameter	2.8mm
Wire Gauge	26 AWG standard

Mating Cordsets / Pin Configuration

8mm female molded locking connectors

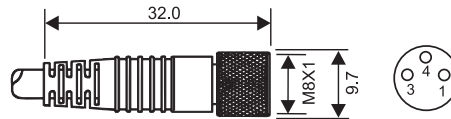

Order part number

Brown = Pin 1
Blue = Pin 3
Black = Pin 4

RC08S-F0M030120 (2m length)
RC08S-F0M030150 (5m length)

Ordering Information

9 H 1 0 - 0 0 0 - □ □ □

Connection Options

0 - 9 ft PVC cable
3 - 8mm quick connect male pigtail*
*Mates with cordsets shown above

Switch [†] Type	Description	Function	Switching Voltage	Switching Current	Switching Power	Voltage Drop	Magnetic Sensitivity
02	Reed Switch with Red LED	Normally Open SPST	5 - 120V AC/DC	0.1 Amps Max.	10 watts Max.	2.5 Volts @ 100mA	60 Ga.
31	Electronic for Reed Magnet, with Grn LED & Sourcing	Normally Open PNP	5 - 28 VDC	0.2 Amps Max.	6 watts Max.	.5 Volts @ 200 mA	40 Ga.
32	Electronic for Reed Magnet, with Red LED & Sinking	Normally Open NPN	5 - 28 VDC	0.2 Amps Max.	6 watts Max.	.5 Volts @ 200 mA	40 Ga.

Ordering Example: 9H10-000-002

9 ft. PVC cable, reed switch with red LED, SPST, 5 - 120V AC/DC 50/60 Hz

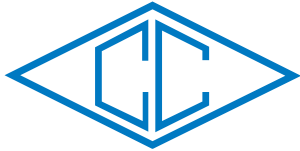

canfield connector
8510 Foxwood Court
Youngstown, Ohio 44514
P:(330) 758-8299 F:(330) 758-8912
www.canfieldconnector.com

9K SERIES

REED & ELECTRONIC MAGNETIC SENSORS
FOR 4.2MM "U" GROOVE APPLICATIONS

General Description

The Canfield Connector 9K Series is a profile mounting type switch that fits in a 4.2mm "U" groove which normally is designed into an aluminum extrusion type linear actuator. Available in reed or electronic versions, the 9K is also available with a 9 ft. PVC or 8mm quick connect male pigtail. The switch is IP67 which is dust tight and water resistant.

Dimensional Data

ALL DIMENSIONS ARE IN MILLIMETERS UNLESS OTHERWISE NOTED

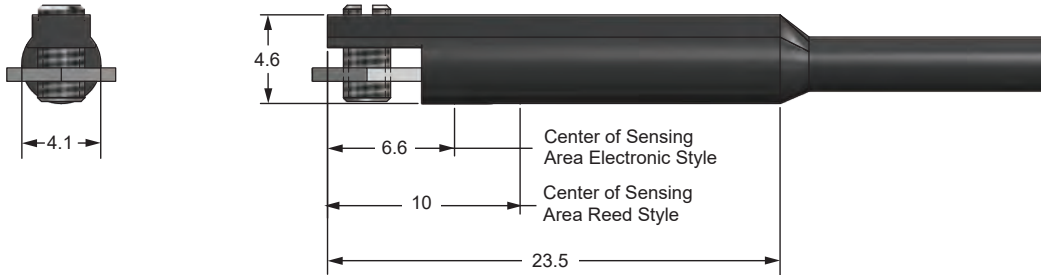

Groove Details

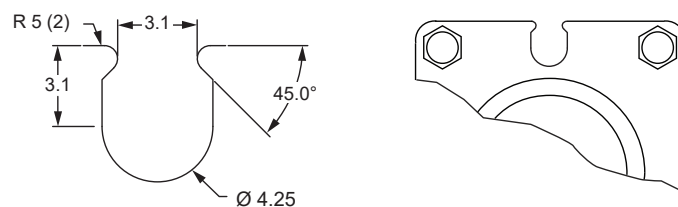

(Fits: Mindman, Koganei)

Sensors

Technical Data

Switch Type / Tech. Specs.	See Ordering Information†
Sensitivity / Orientation	Electronic: 25 Gauss Parallel Reed: 85 Gauss Parallel (measured from sensor surface)
Shock	Up to 30G (11mS) Reed Only (not applicable for electronics)
Vibration	Up to 20G (10-55 Hz) Reed only
Materials	Cable: PVC House: PBT
Temperature Range	-20° to +80°C
Environmental Protection	Designed for IP 67 / NEMA 6
Cable Diameter	2.8mm
Wire Gauge	26 AWG standard

Mating Cordsets / Pin Configuration

8mm female molded locking connectors

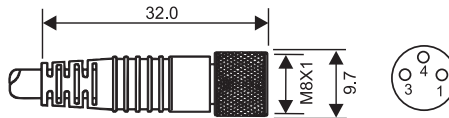

Order part number

Brown = Pin 1
Blue = Pin 3
Black = Pin 4

RC08S-F0M030120 (2m length)
RC08S-F0M030150 (5m length)

Ordering Information

9 K 1 0 - 0 0 0 - □ □ □

Connection Options

0 - 9 ft PVC cable
3 - 8mm quick connect male pigtail*
*Mates with cordsets shown above

Switch† Type	Description	Function	Switching Voltage	Switching Current	Switching Power	Voltage Drop	Magnetic Sensitivity
02	Reed Switch with Red LED	Normally Open SPST	5 - 120V AC/DC	0.03 Amps Max.	4 watts Max.	2.5 Volts	60 Ga.
31	Electronic for Reed Magnet, with Grn LED & Sourcing	Normally Open PNP	5 - 28 VDC	0.2 Amps Max.	4.8 watts Max.	.5 Volts	40 Ga.
32	Electronic for Reed Magnet, with Red LED & Sinking	Normally Open NPN	5 - 28 VDC	0.2 Amps Max.	4.8 watts Max.	.5 Volts	40 Ga.

Ordering Example: 9K10-000-002

9 ft. PVC cable, reed switch with red LED,
SPST, 5 - 120V AC/DC 50/60 Hz

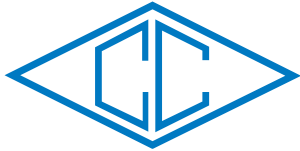

canfield connector
8510 Foxwood Court
Youngstown, Ohio 44514
P:(330) 758-8299 F:(330) 758-8912
www.canfieldconnector.com

9M50 SERIES

REED & ELECTRONIC SENSORS
FOR 6.5MM GROOVE APPLICATIONS

General Description

The Canfield Connector 9M50 Series is a compact full featured magnetic proximity switch designed to fit a "D" shaped groove detail designed into linear actuators. The innovative design allows the switch to be inserted anywhere along the linear actuator and then rotated and locked into position. When installed the switch lies flat against the cylinder housing and does not protrude beyond the cylinder face making installations neat and clean. The fully encapsulated switch is offered in reed, and electronic styles in either NPN or PNP. The robust polyurethane encapsulated design meets IP67, NEMA 6 environmental protection. Voltage ranges are available from 0 to 120 VAC/DC in multiple versions. Standard connection is provided by a 9 ft. PVC or 8mm quick connect male pigtail and is proudly made in the U.S.A.

Dimensional Data

ALL DIMENSIONS ARE IN MILLIMETERS UNLESS OTHERWISE NOTED

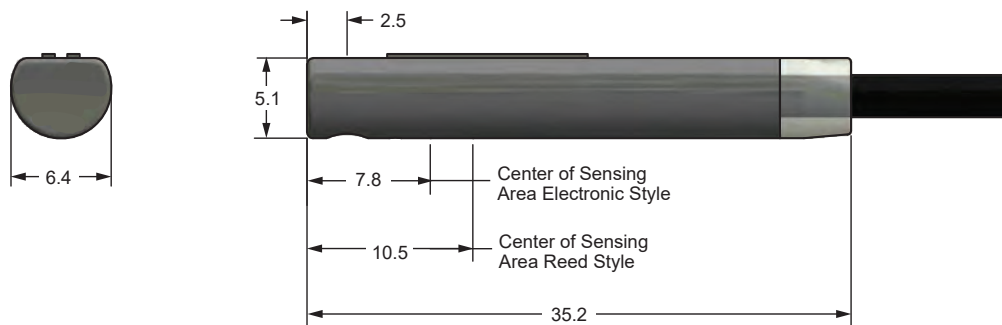

Groove Details

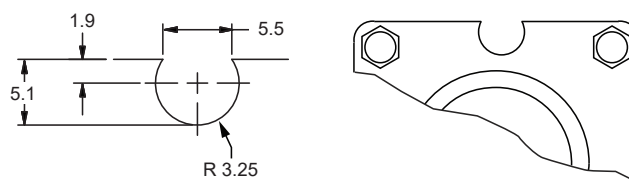

(Fits: Norgren)

Technical Data

Switch Type / Tech. Specs.	See Ordering Information†
Sensitivity / Orientation	Electronic: 25 Gauss Parallel Reed: 85 Gauss Parallel (measured from sensor surface)
Shock	Up to 30G (11mS) Reed Only (not applicable for electronics)
Vibration	Up to 20G (10-55 Hz) Reed only
Materials	Cable: PVC House: PEI, TPU
Temperature Range	-20° to +80°C
Environmental Protection	Designed for IP 67 / NEMA 6
Cable Diameter	2.7mm
Wire Gauge	26 AWG standard

Mating Cordsets / Pin Configuration

8mm female molded locking connectors

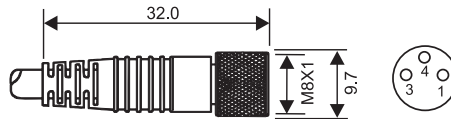

Order part number

Brown = Pin 1
Blue = Pin 3
Black = Pin 4

RC08S-F0M030120 (2m length)
RC08S-F0M030150 (5m length)

Ordering Information

9 M 5 0 1 0 - 0 0 0 - □ □ □

Connection Options

0 - 9 ft PVC cable
3 - 8mm quick connect male pigtail*
*Mates with cordsets shown above

Switch [†] Type	Description	Function	Switching Voltage	Switching Current	Switching Power	Voltage Drop	**Magnetic Sensitivity
01	Reed Switch	Normally Open SPST	0 - 120V AC/DC 50/60 Hz	0.25 Amps Max.	5 watts Max.	0 Volts	85 Ga.
02	Reed Switch for PLC's Red LED (current limiting)	Normally Open SPST	5 - 120V AC/DC 50/60 Hz	0.03 Amps Max. 0.001 Amps Min.	4 watts Max.	3.5 Volts	85 Ga.
31	Electronic for Reed Magnet, Yel LED & Sourcing	Normally Open PNP	5 - 28 VDC	0.2 Amps Max.	4.8 watts Max.	1.0 Volts	25 Ga.
32	Electronic for Reed Magnet, Red LED & Sinking	Normally Open NPN	5 - 28 VDC	0.2 Amps Max.	4.8 watts Max.	1.0 Volts	25 Ga.

†Minimum gauss rating required for proper operation. Size of sensing area depends upon size and strength of magnet and thickness of cylinder wall.

Ordering Example: 9M5010-000-002

9 ft. PVC cable, reed switch with Red LED, SPST, 5 - 120V AC/DC 50/60 Hz

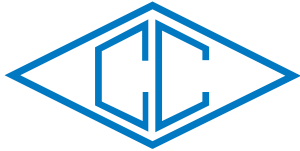

canfield connector
8510 Foxwood Court
Youngstown, Ohio 44514
P:(330) 758-8299 F:(330) 758-8912
www.canfieldconnector.com

9Q SERIES

REED & ELECTRONIC SENSORS
FOR UNIVERSAL "T" SLOT APPLICATIONS

General Description

The Canfield Connector 9Q Series is a magnetic proximity switch that is engineered to fit into extruded actuators that are made with a "T" slot. The unique design of the 9Q enables it to be installed anywhere along the slot and assembled in place without taking off the actuator end-cap. The rugged polyurethane encapsulated switch features an innovative design that incorporates a hard nylon shell. The switches are available in reed or electronic sensing and features a standard on board indicator light. Offered as a flying lead or 8mm quick connect, the sensors are quickly and easily wired in to any application. The sensors meet NEMA 6 / IP67 environmental specifications and are corrosion and wash-down compatible. This sensor is proudly made in the USA.

Dimensional Data

ALL DIMENSIONS ARE IN MILLIMETERS UNLESS OTHERWISE NOTED

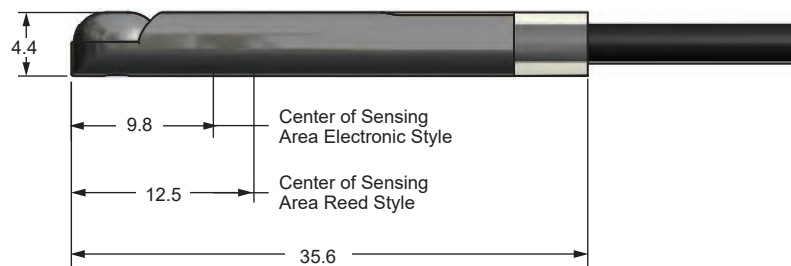

Groove Details

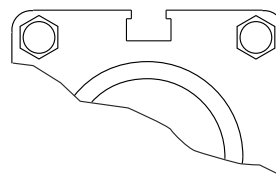
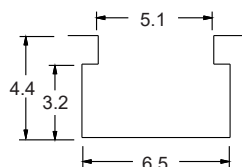

(Fits: Parker, Fabco, Festo, Numatics, Rotomation)

Technical Data

Switch Type / Tech. Specs.	See Ordering Information [†]
Sensitivity / Orientation	Electronic: 25 Gauss Parallel Reed: 85 Gauss Parallel (measured from sensor surface)
Shock	Up to 30G (11mS) Reed Only (not applicable for electronics)
Vibration	Up to 20G (10-55 Hz) Reed only
Materials	Cable: PVC House: PEI, TPU
Temperature Range	-20° to +80°C
Environmental Protection	Designed for IP 67 / NEMA 6
Cable Diameter	2.7mm
Wire Gauge	26 AWG standard

Mating Cordsets / Pin Configuration

8mm female molded locking connectors

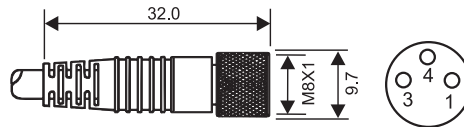

Brown = Pin 1
Blue = Pin 3
Black = Pin 4

Order part number

RC08S-F0M030120 (2m length)
RC08S-F0M030150 (5m length)

Ordering Information

9 Q 1 0 - 0 0 0 - □ □ □

Connection Options

0 - 9 ft PVC cable
3 - 8mm quick connect male pigtail*
*Mates with cordsets shown above

Switch [†] Type	Description	Function	Switching Voltage	Switching Current	Switching Power	Voltage Drop	Magnetic Sensitivity
01	Reed Switch	Normally Open SPST	0 - 120V AC/DC 50/60 Hz	0.25 Amps Max.	5 watts Max.	0 Volts	85 Ga.
02	Reed Switch for PLC's, Red LED (current limiting)	Normally Open SPST	5 - 120V AC/DC 50/60 Hz	0.03 Amps Max. 0.001 Amps Min.	4 watts Max.	3.5 Volts @ 5mA	85 Ga.
31	Electronic for Reed Magnet, Yel LED & Sourcing	Normally Open PNP	5 - 28 VDC	0.2 Amps Max.	4.8 watts Max.	1.0 Volts	25 Ga.
32	Electronic for Reed Magnet, Red LED & Sinking	Normally Open NPN	5 - 28 VDC	0.2 Amps Max.	4.8 watts Max.	1.0 Volts	25 Ga.

Ordering Example: 9Q10-000-002

9 ft. PVC cable, reed switch for PLC's with LED, SPST, normally open, 5 - 120V AC/DC 50/60 Hz

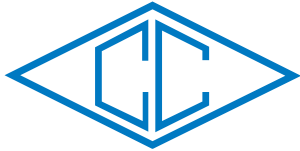

canfield connector
8510 Foxwood Court
Youngstown, Ohio 44514
P:(330) 758-8299 F:(330) 758-8912
www.canfieldconnector.com

9T SERIES

REED & ELECTRONIC MAGNETIC SENSORS FOR 7.2MM "T" SLOT APPLICATIONS

General Description

The Canfield Connector 9T Series is a compact yet robust switch used to sense position of magnetic pistons designed into aluminum extrusion type linear actuators. The 9T fits a 7.2mm X 3.9mm rectangular groove which is designed into the actuator body. Available in reed or electronic versions, the 9T features standard 9 ft. PVC or 8mm quick connect male pigtail, and are rated IP-67 against the ingress of dust and water.

Dimensional Data

ALL DIMENSIONS ARE IN MILLIMETERS UNLESS OTHERWISE NOTED

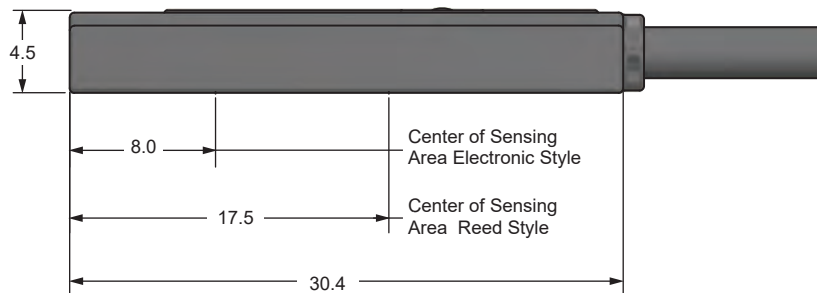
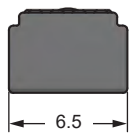

Groove Details

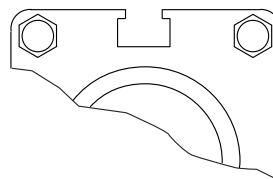
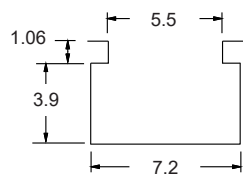

(Fits: SMC)

Sensors

Technical Data

Switch Type / Tech. Specs.	See Ordering Information [†]
Sensitivity / Orientation	Electronic: 25 Gauss Parallel Reed: 85 Gauss Parallel (measured from sensor surface)
Shock	Up to 30G (11ms) Reed Only (not applicable for electronics)
Vibration	Up to 20G (10-55 Hz) Reed only
Materials	Cable: PVC House: PA
Temperature Range	-20° to +80°C
Environmental Protection	Designed for IP 67 / NEMA 6
Cable Diameter	2.8mm
Wire Gauge	26 AWG standard

Mating Cordsets / Pin Configuration

8mm female molded locking connectors

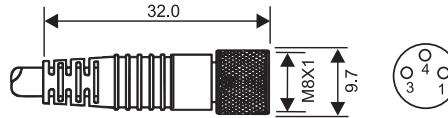

Order part number

Brown = Pin 1
Blue = Pin 3
Black = Pin 4

RC08S-F0M030120 (2m length)
RC08S-F0M030150 (5m length)

Ordering Information

9 T 1 0 - 0 0 0 - □ □ □

Connection Options

0 - 9 ft PVC cable
3 - 8mm quick connect male pigtail*
**Mates with cordsets shown above*

Switch Type [†]	Description	Function	Switching Voltage	Switching Current	Switching Power	Voltage Drop	Magnetic Sensitivity
02	Reed Switch with Red LED	Normally Open SPST	5 - 240V AC/DC	0.1 Amps Max.	10 watts Max.	2.5 Volts @ 100mA	60 Ga.
31	Electronic for Reed Magnet, with Grn LED & Sourcing	Normally Open PNP	5 - 28 VDC	0.2 Amps Max.	6 watts Max.	.5 Volts @ 200 mA	40 Ga.
32	Electronic for Reed Magnet, with Red LED & Sinking	Normally Open NPN	5 - 28 VDC	0.2 Amps Max.	6 watts Max.	.5 Volts @ 200 mA	40 Ga.

Ordering Example: 9T10-000-002

9 ft. PVC cable, reed switch with red LED, SPST, 5 - 240V AC/DC 50/60 Hz

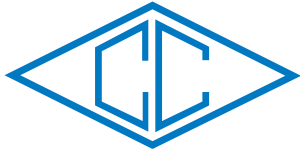

canfield connector
8510 Foxwood Court
Youngstown, Ohio 44514
P:(330) 758-8299 F:(330) 758-8912
www.canfieldconnector.com

CS SERIES

ALL THREADED MAGNETIC SENSORS
FOR UNIVERSAL APPLICATIONS

General Description

The Canfield Connector CS Series Cylindrical Threaded Mount Sensor is a rugged and compact magnetic sensor set within a miniature encapsulated Stainless Steel M8 threaded housing. Available in reed or electronic sensing, the CS sensor can sense magnets or magnetic objects in industrial machinery and mobile equipment. Typically used where greater sensing distance is required, the CS sensor changes state in the presence of a magnetic field. Electrical output for the CS is normally open, with sinking or sourcing outputs for the electronic versions. Input voltages available are 0 to 120 VAC/DC .5 Amp maximum for the reed and 5-24 VDC 0.2 Amp maximum for the electronic versions. The sensor is made of a Stainless Steel body, TPU encapsulant and has PVC wire standard and is NEMA 6. Temperature ranges are -20° to 80°C. The CS Series is proudly made in the U.S.A.

Dimensional Data

ALL DIMENSIONS ARE IN MILLIMETERS UNLESS OTHERWISE NOTED

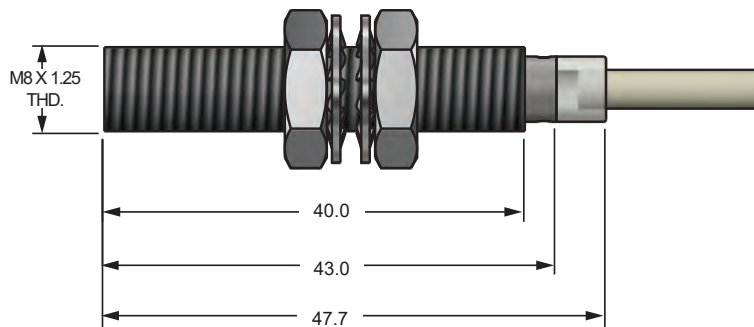
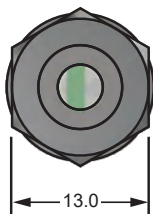
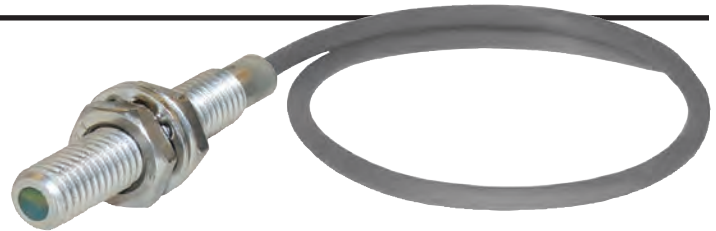

Mounting Orientation

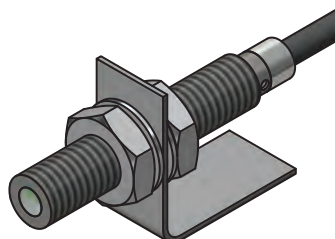

Technical Data

Switch Type / Tech. Specs.	See Ordering Information†
Sensitivity / Orientation	Electronic: 25 Gauss Parallel Reed: 85 Gauss Parallel (measured from sensor surface)
Shock	Up to 30G (11mS) Reed Only (not applicable for electronics)
Vibration	Up to 20G (10-55 Hz) Reed only
Materials	Cable: PVC House: 300 Series Stainless Steel, TPU
Temperature Range	-20° to +80°C
Environmental Protection	Designed for IP 67 / NEMA 6
Cable Diameter	2.7mm
Wire Gauge	24 AWG standard

Mating Cordsets / Pin Configuration

8mm female molded locking connectors

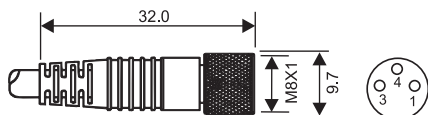

Brown = Pin 1
Blue = Pin 3
Black = Pin 4

Order part number
RC08S-F0M030120 (2m length)
RC08S-F0M030150 (5m length)

12mm female molded locking connector

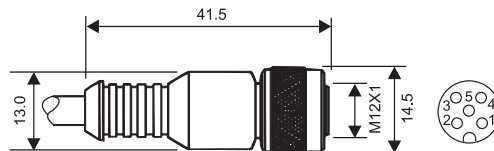

Brown = Pin 1
Blue = Pin 3
Black = Pin 4
N/C = Pin 2
N/C = Pin 5

Order part number
RC12S-F0M030120 (2m length)
RC12S-F0M030150 (5m length)

Ordering Information

CSM0810 - [] [] [] - 0 []

Connection Options

0 - 9 ft PVC cable
3 - 8mm quick connect male pigtail*
5 - 12mm quick connect male pigtail*
*Mates with cordsets shown above

Special Packaging

A - Bulk
G - Individually Bagged

Switch† Type	Description	Function	Switching Voltage	Switching Current	Switching Power	Voltage Drop	Magnetic Sensitivity
01	Reed Switch	Normally Open SPST	0 - 120V AC/DC 50/60 Hz	0.5 Amps Max.	5 Watts Max.	0 Volts	85 Ga.
31	Electronic for Reed Magnet, No LED & Sourcing	Normally Open PNP	5 - 24 VDC	0.2 Amps Max.	4.8 Watts Max.	1.0 Volts	25 Ga.
32	Electronic for Reed Magnet, No LED & Sinking	Normally Open NPN	5 - 24 VDC	0.2 Amps Max.	4.8 Watts Max.	1.0 Volts	25 Ga.

Ordering Example: CSM0810-001-0A

9 ft. PVC cable, Reed Switch, Normally Open,
0-120V AC/DC 50/60 Hz, Bulk Packaged.

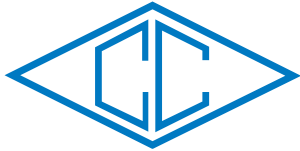

canfield connector
 8510 Foxwood Court
 Youngstown, Ohio 44514
 P:(330) 758-8299 F:(330) 758-8912
 www.canfieldconnector.com

EiS SERIES



**ELECTRONIC INCLINOMETER
 SENSOR**

General Description

The Canfield Connector Electronic Inclinometer Sensor EiS is an instrument designed to measure angles of slope, tilt, or elevation of an object with respect to gravity based on an artificial horizon. Synonyms include tilt sensor, tilt switch, clinometer, slope sensor, slope gauge, level sensor, level meter, tiltmeter or pitch and roll sensor. The EiS is an all solid-state, MEMs device designed to measure tilt while reporting the data within 0.3 degrees accuracy +/- 85° with an analog output of .5 to 9.5 Volts DC, 4 -20mA. The unit features a miniature metal housing and is epoxy encapsulated for vibration, water and dust resistance and is rated up to IP 69K environmental rating. Available in 1 or 2 axis versions, the unit boasts a temperature drift of +/- 1° maximum with a temperature range of -40 to 80° C. The EiS is precisely calibrated to remove non-linearity in the sensing range. Applications for inclinometers such as the EiS include platform leveling, motion sensing, filter vibrations, boom angle sensing, cameras, machine arm angle sensing as well as mobile security systems. The unit comes with high quality 9 ft. PVC jacketed wire, other lengths and quick connections as options, and is mounted in place by use of two 4.21mm holes.

Dimensional Data

ALL DIMENSIONS ARE IN MILLIMETERS UNLESS OTHERWISE NOTED

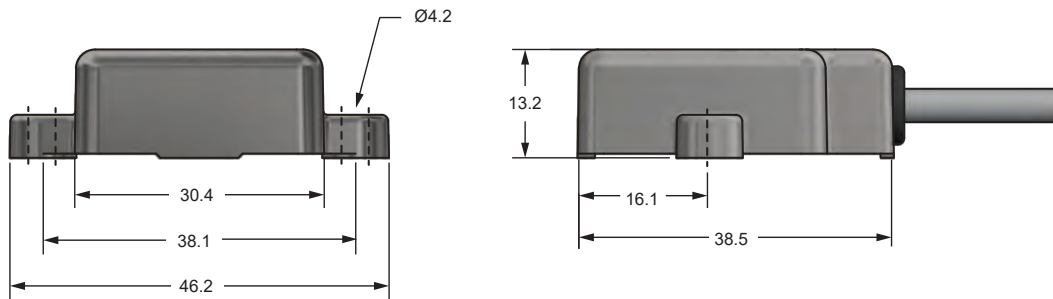
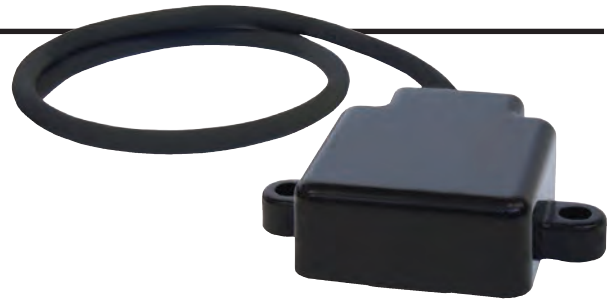

Mounting / Sensing Orientation

Mounted on Horizontal Surface

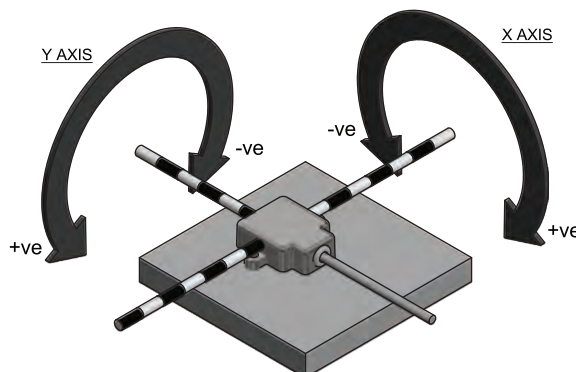

Sensors

Accuracy @ 20°C	0.3°
Environmental Protection	Up to IP 69K
Materials	Cable: PVC (others available on request) Housing: Zinc die-cast Housing Finish: Black powder coat
Number of Axis	Single: 1 Dual: 2
Output Current	10 mA Maximum (Voltage Output Units)
Output Format	Analog
Output Type	0.5 - 4.5VDC 0.5 - 9.5 VDC 4 - 20 mA
Range	+/- 85°C
Supply Voltage	12-24 VDC
Temperature Drift	+/- 1° Maximum
Temperature Range	-40° to +80°C
Wire Gauge	24 AWG

Mating Cordsets / Pin Configuration

8mm female molded locking connectors

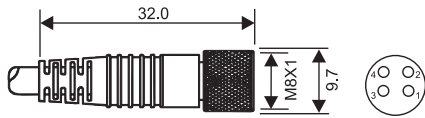

Brown = Pin 1
White = Pin 2
Blue = Pin 3
Black = Pin 4

Order part number
RC08S-F0M040120 (2m length)
RC08S-F0M040150 (5m length)

12mm female molded locking connector

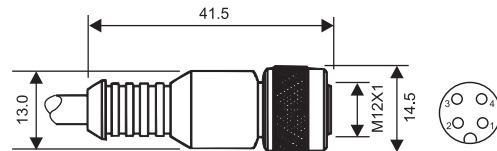

Brown = Pin 1
White = Pin 2
Blue = Pin 3
Black = Pin 4

Order part number
RC12S-F0M040120 (2m length)
RC12S-F0M040150 (5m length)

Ordering Information

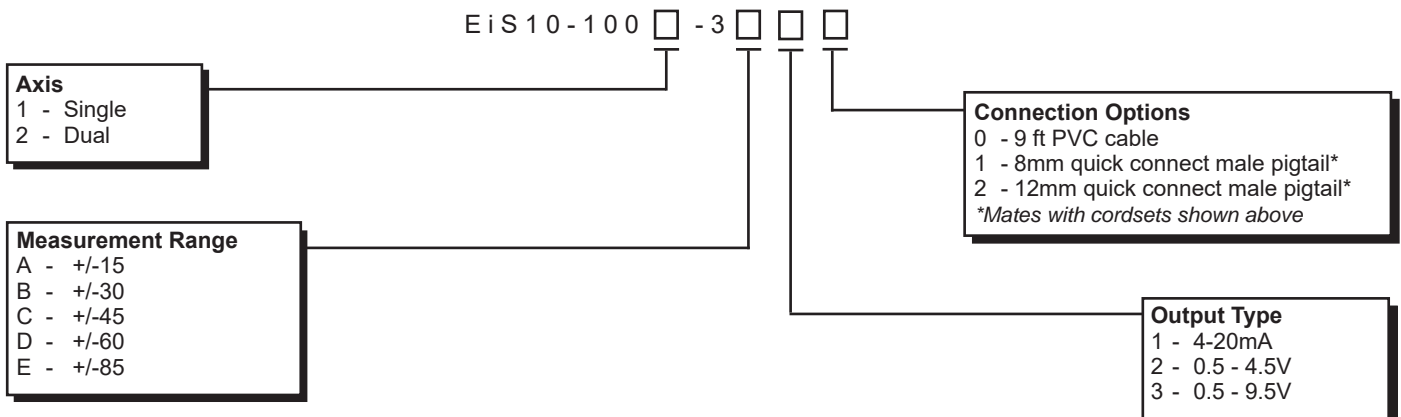

Ordering Example: EiS10-1001-3A10
Single Axis, +/-15 Range, 4-20mA, 9 ft. PVC cable.

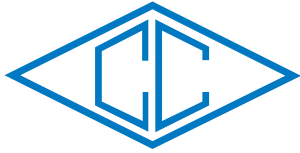

canfield connector
 8510 Foxwood Court
 Youngstown, Ohio 44514
 P:(330) 758-8299 F:(330) 758-8912
 www.canfieldconnector.com

D5400 SERIES **Coil Saver®**

**MICRO SOLENOID DRIVER
 POWER CONVERTER**

General Description

The Canfield Connector D5400 Series Micro Solenoid Driver is a NEMA 4 DIN Style "A" EN175301-803 (Formerly DIN 43650) and MINI type connector with a built in electronic circuit used to induce solenoid pull-in and reduce holding current. The time proven MSD has been designed into many applications where heat buildup occurs which reduces operating efficiency and life span of solenoid valves. The MSD has two main functions: one is to induce faster or stronger than usual response times at solenoid pull-in, the second is to reduce the net wattage of the solenoid during hold-in. The MSD drives the coil with a high input voltage for a fixed time period until the coil has shifted at which time the MSD reduces the holding voltage, which saves power, and the solenoid runs cool. The MSD Series is often used to replace low voltage power supplies where a 24 VDC solenoid valve can then be operated by 120 VAC. The Alternating current is rectified and the duty cycle reduced so as to operate the valve at proper voltage and wattage ranges. An additional advantage can be found when the MSD drops the holding voltage, which then reduces heat and current requirements.

Dimensional Data

ALL DIMENSIONS ARE IN MILLIMETERS UNLESS OTHERWISE NOTED



Proportional, Timers
Electronics

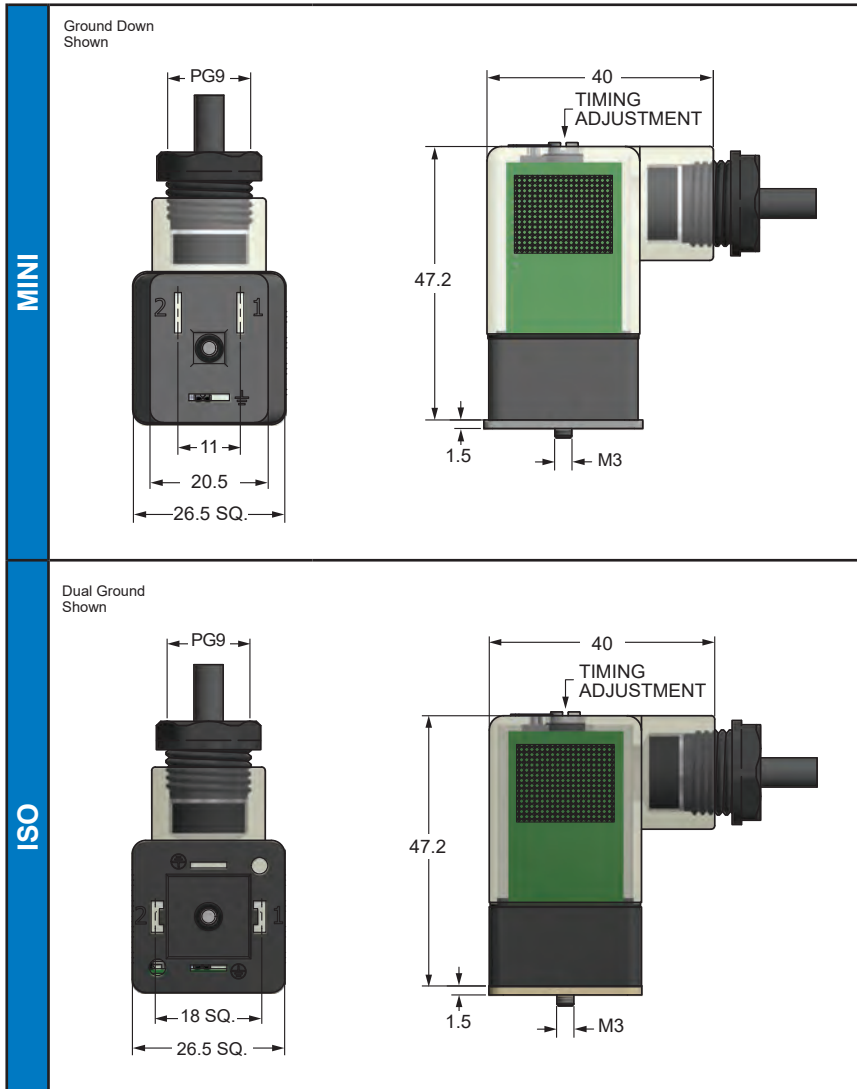

Technical Data

Output Current	Inrush: 8 Amps for 50 ms Holding: 1 Amp
Output Voltage	10% - 70% DC of Input
Input Voltage Max.	240 VAC, 24 VDC
Allowable Input Voltage DC	20% peak to peak
Materials	Housing: Nylon, Black; Translucent (lighted versions) Interface: Nylon, Black Gasket: Nitrile
Temp Range	-20° to +50°C
Gasket Temperature Max.	Nitrile: -25° to +90°C
Environmental Protection	NEMA 4
Cable Diameter	PG7 0.157" to 0.236" O.D. 1/2" Conduit 0.410" max.
Wire Gauge	20 AWG
Size	ISO: 18mm pin spacing - DIN Style "A" EN175301-803 MINI: 11mm pin spacing - Industry Standard
Number of Contacts	2+ ground

NOTE: Slight discoloration may occur to translucent material after prolonged exposure to UV rays.

Output Waveforms

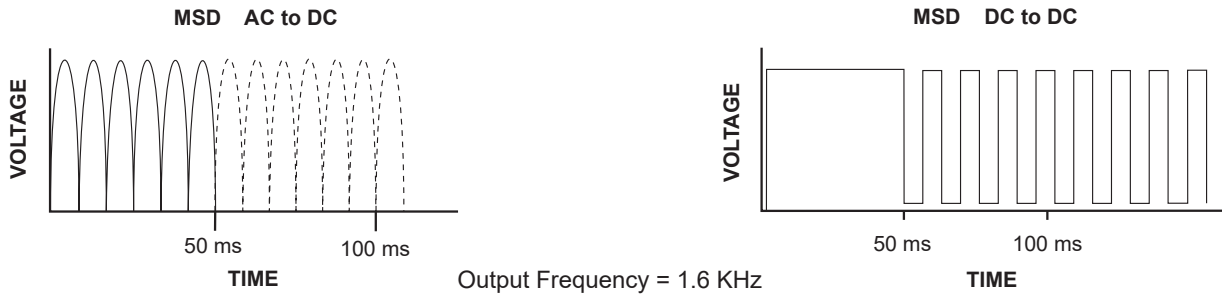

The MSD allows the input line voltage directly to the coil for a fixed single shot of 50 milliseconds. After that period, the MSD automatically pulses the input voltage to the coil. In either fixed or adjustable versions, the MSD turns the power on and off so fast that the armature does not respond. By adjusting the off period so that it is longer than the on period, the net RMS voltage decreases and wattage is decreased. Many coils can be adjusted much lower than expected due to the fact that much less energy is required for hold-in as opposed to pull-in.

Ordering Information

Each connector kit contains screw, washer and gasket assembly.

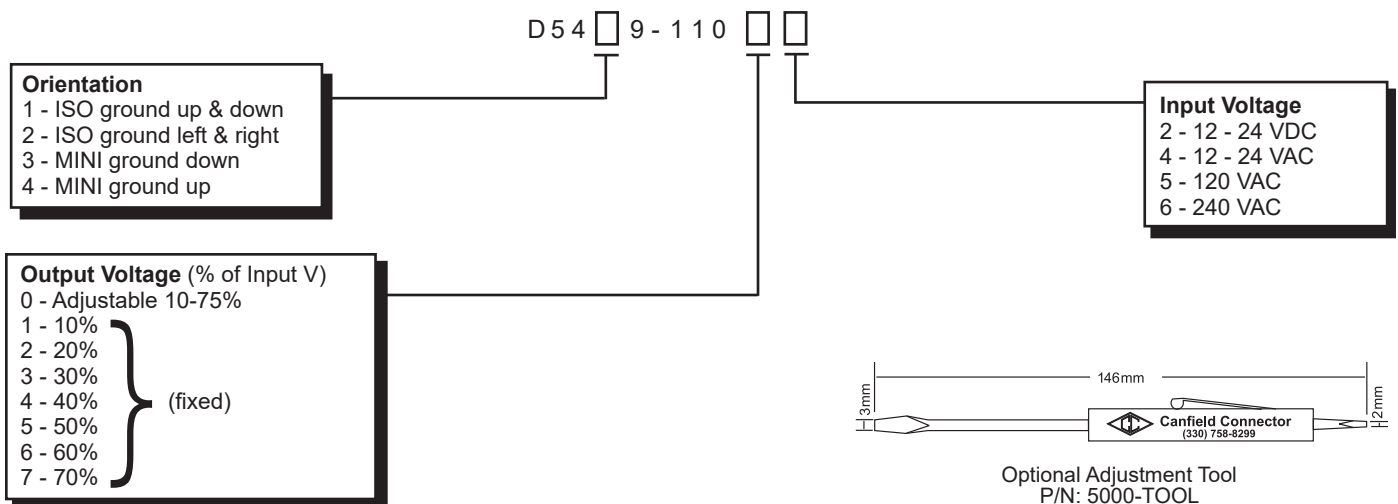

Ordering Example: D5439 - 11005

MINI ground down, Adjustable output, 120 VAC

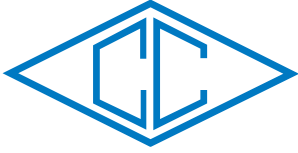

5800 SERIES

**MICRO LOGIC
 TIMER**

General Description

The Canfield Connector 5800 Series Micro Logic Timer is a solid state electronic timing unit incorporated inside the standard MINI and DIN Style "A" EN175301-803 (Formerly DIN 43650) electrical connectors. The MLT allows precise timing and logic functions in a small, easily mounted enclosure. There are eight standard timer types. Each timer incorporates circuitry for AC or DC operation with a wide voltage range.

Dimensional Data

ALL DIMENSIONS ARE IN MILLIMETERS UNLESS OTHERWISE NOTED



Proportional Timers
Electronics

MINI

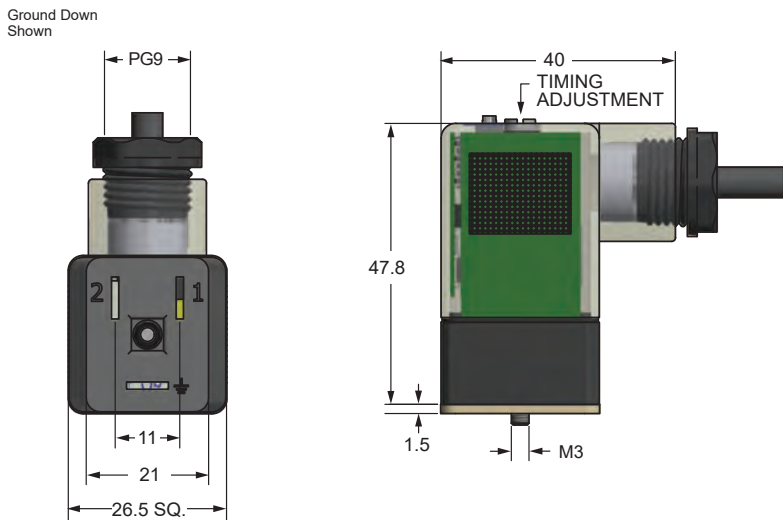

ISO

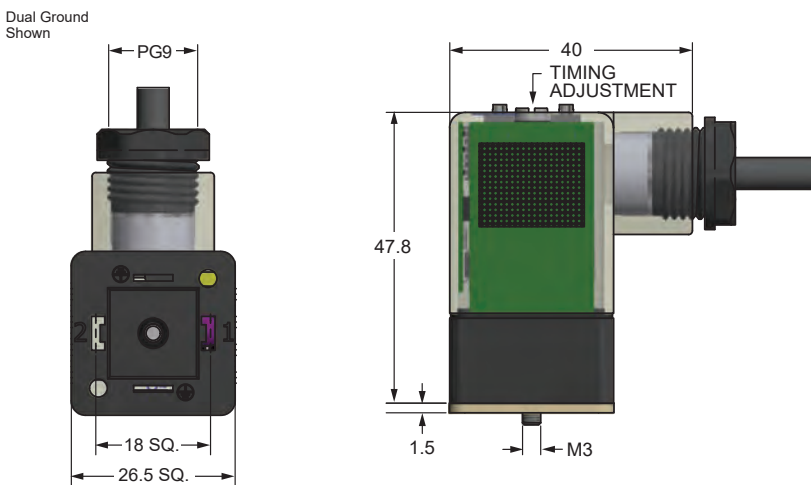

Consult factory for available versions listed by Canadian Standards Association for use with certified electrical equipment.

TIMER TYPE 1

Solenoid is energized for ΔT upon application of power. Reset occurs when power is removed.

Interval Delay/(One Shot)

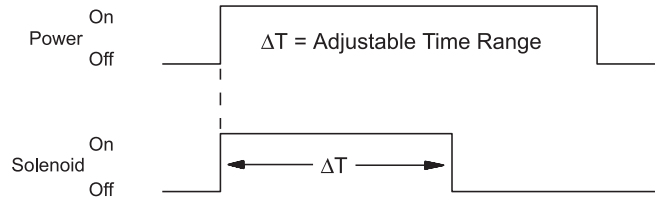

TIMER TYPE 2

Solenoid remains OFF for ΔT upon application of power. Reset occurs when power is removed.

On Delay/(Delay On Make)

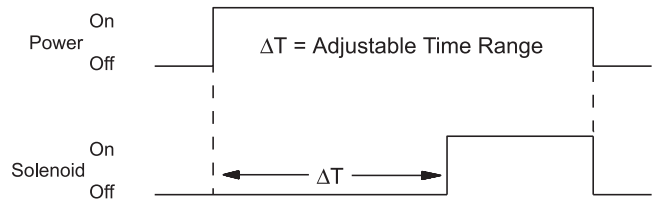

TIMER TYPE 3

When power is applied, solenoid remains OFF. Solenoid is energized for ΔT only upon closure of a normally open momentary contact switch (trigger). Reset occurs when solenoid is OFF and trigger is re-applied.

Off Delay/(Triggered One Shot)

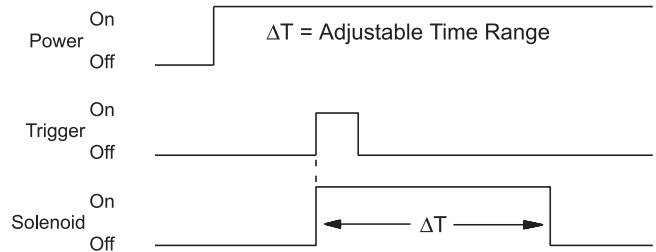

TIMER TYPE 4 / A

Solenoid cycles ΔT_1 OFF and ΔT_2 ON when power is applied. Reset occurs when power is removed. Timer is available in normally on (Type A) or normally off (Type 4) versions.

Cycle Timer

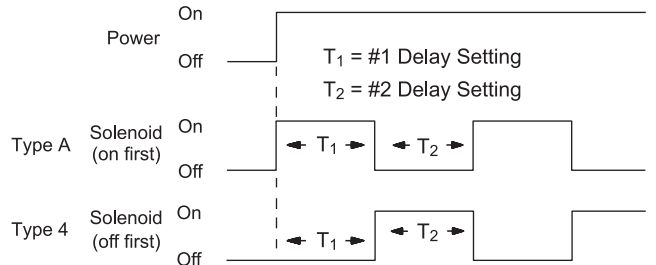

TIMER TYPE 5 / 9

Solenoid cycles with equal ON and OFF times when power is applied. Reset occurs when power is removed. Timer is available in normally on (Type 5) or normally off (Type 9) versions.

Square Wave Cycle Timer

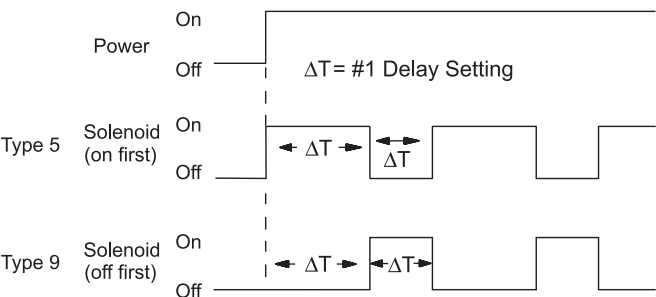

TIMER TYPE 6

When power is applied, solenoid remains OFF. Solenoid is energized for $\Delta T_c + \Delta T$ when trigger switch is closed and opened. Reset occurs when solenoid is OFF and trigger is re-applied.

Delay On Break Normally Off

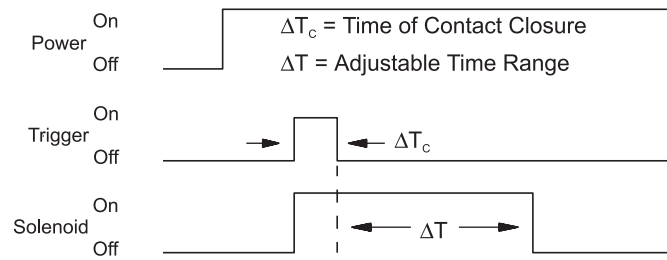

TIMER TYPE 7

When power is applied, solenoid is energized and remains energized until the trigger switch is closed. Solenoid is then OFF for $\Delta T_c + \Delta T$. Reset occurs when solenoid is ON and the trigger is re-applied.

Delay On Break Normally On

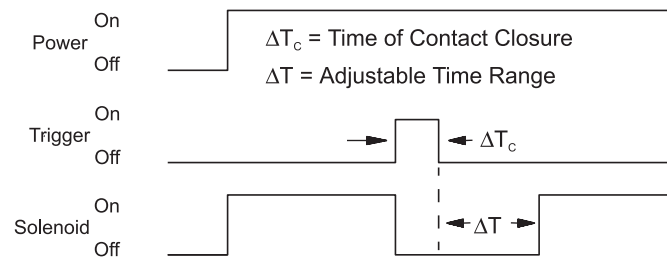

TIMER TYPE 8

When power is applied, the solenoid is energized. Solenoid de-energizes for ΔT only upon closure of a normally open momentary contact switch (trigger). Reset occurs when solenoid is ON and the trigger is re-applied.

Triggered One Shot Normally On

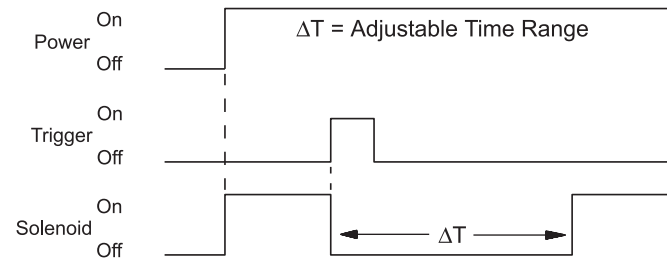

TIMER TYPE B / C

Solenoid cycles ΔT_1 OFF and ΔT_2 ON when power is applied. Reset occurs when power is removed. Timer is available in normally off (Type B) or normally on (Type C).

Single Cycle Timer

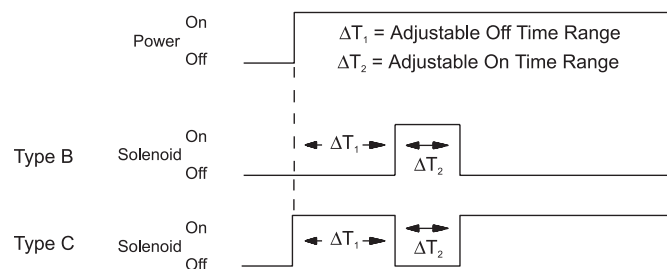

Technical Data

Input Voltage Range	12-240 VDC, 24-240 VAC (50/60 Hz)
Max. Input Voltage	Tolerance: +/-10%
Max. Output Current	1 Amp
Frequency	AC 50/60 Hz or DC
Time Ranges	0.1 sec. to 33 min.; Standard
Timer Repeat Accuracy	+/-0.5%; Under normal conditions
Surge Suppression	MOV
Materials	Housing: PC
Indicator Light	Red
Ambient Rated Temp.	-20° to +60°C
Environmental Protection	IP 65 and NEMA 4
Cable Diameter	0.240"
Cable Conductor Color	Brown, Green, White (Trigger; Yellow, Gray)
Cable Type	Pressure Extruded PVC Jacket
Wire Gauge	20 AWG; Standard

NOTE: Slight discoloration may occur to translucent material after prolonged exposure to UV rays.

Ordering Information

Each kit contains all mounting hardware and gasket assembly..

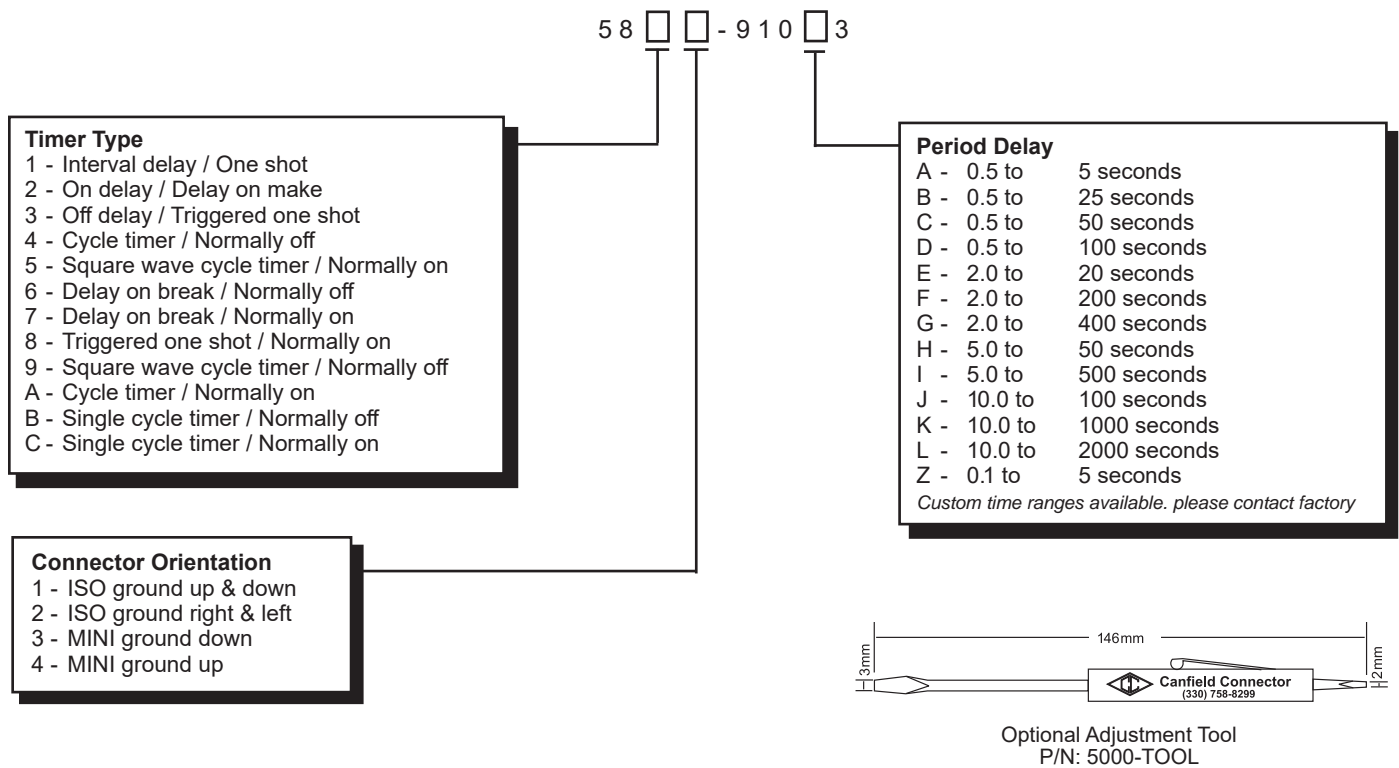

Ordering Example: 5811-910A3

Interval Delay, ISO ground up & down,
0.5 to 5 second delay

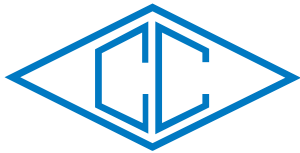

5950 SERIES

MICRO PROPORTIONAL DRIVER

General Description

A Micro Proportional Driver provides accurate control of hydraulic and pneumatic proportional solenoid valves used in mobile construction equipment and industrial processes. The MPD can control the flow of air or liquid linearly at a setting from 0.10-20 seconds. One example of use would be in a paint system. The MPD allows a solenoid to oscillate, significantly reducing system shock and wear commonly found in non-oscillation digital valve systems. The Micro Proportional Driver is a compact electronic circuit built into an environment-resistant miniaturized enclosure. The circuit features control of proportional solenoids and operators. Functions include minimum and maximum current limiting, control signals from 0-10V or 0-20 mA (with a step function at 0.2V or 0.4 mA included for minimum current), a 0.1-20 sec. linear ramp up/ramp down adjustment and output current proportional to input command signal.

Dimensional Data

ALL DIMENSIONS ARE IN MILLIMETERS UNLESS OTHERWISE NOTED

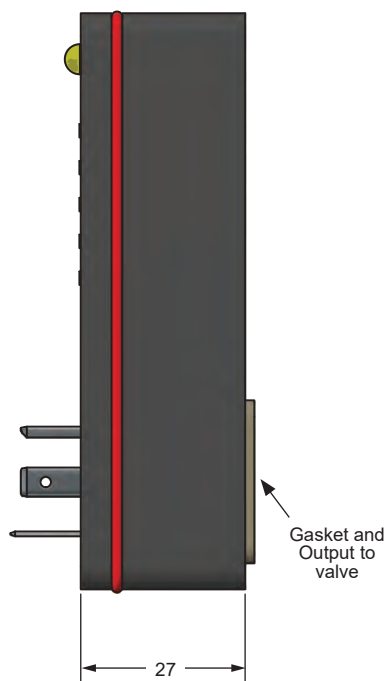
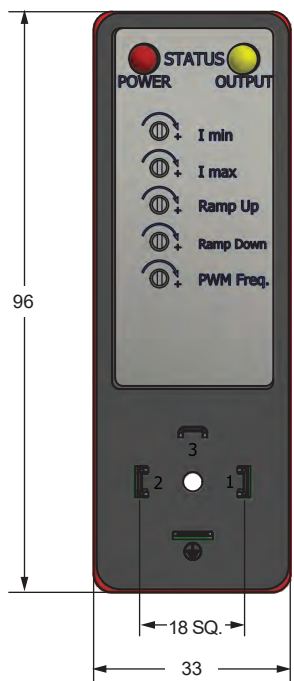
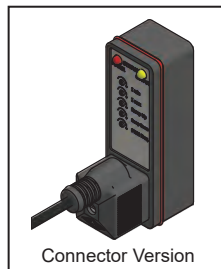

Technical Data

Output Current @ 25° C_A Continuous Peak Pulsed (16ms) I min. (+/- 20%) I min. (+/- 20%)	High Resolution Version: 1.5 Amps max. 4.7 Amps max. 0 - 0.5 Amps max. I min. + 1.0 Amps max.	High Output Version: 3.0 Amps max. 17.0 Amps max. 0 - 1.0 Amps max. I min. + 2.0 Amps max.
Supply Voltage	11.5 VDC min. - 32 VDC max.	
Supply Current	45 mA max. (no load)	
Input Control Signal Control Voltage Control Current Regulation Δ V Regulation Δ T Ramping Up/Down Time PWM Frequency Output Leap to I min.	0 - 10 VDC (500 Ω impedance) 0 - 20 mA (100 Ω impedance) +/- 0.2% / V +/- 0.1% / °C 0.1 - 20 sec. linear (+/- 0.1% / °C) 95 - 225 Hz @ 0.2 V or 0.4 mA control (+/- 15%)	
Temperature Range	-25° to +85°C	
Materials	Housing: PA	
Environmental Protection	IP 65 and NEMA 4 (When properly installed)	
Size	ISO: 18mm pin spacing - DIN Style "A" EN175301-803	

Function

Minimum Current & Maximum Current - These two adjustments will vary the minimum and maximum output current limits. The minimum current can be set between 0 - 500 mA or 0 - 1 A, depending on output current option. The maximum current can be set in the range between the minimum current setting and the minimum current setting plus 1 A or 2 A, depending on output current option. The minimum current must be set first as described below.

Minimum Current Adjustment - Set both min. and max. current adjusters max. counterclockwise. Apply an input command signal of approximately 0.5 volts or 1.0 mA. Adjust the min. current adjuster for a minimum current or to a desired system response. Back up adjuster until system stops responding. Proceed to max. current adjuster.

Maximum Current Adjustment - Increase the input command signal to 10 volts or 20 mA. Adjust max. current adjuster for a maximum current limit or to a desired system response.

Note: To minimize any effect of supply voltage, load resistance or temperature variation, make setup adjustments when these

parameters are at the midpoint of the expected operating range for a particular installation. For example, if the expected operating temperature range is 20° C to 60° C, make final setup adjustments when system is approximately 40° C. If the supply voltage has a tolerance of 22 to 32 volts, make adjustments when the supply voltage is approximately 27 VDC.

Ramp Up/Ramp Down - Adjust to desired ramp up/ramp down time (0.10 - 20 sec.). Ramp time is linear and is proportional to the step change in the control signal. For example: 0.2 - 10 VDC change in control signal gives max. ramp of 20 sec. 0.2-5 VDC change in control signal gives max. ramp of 10 sec.

PWM Frequency - The output is pulse-width modulated to control output current within the minimum and maximum current settings. The frequency of the modulation is continuously adjustable from 95 - 225 Hz.

Output - The output is current regulated and will remain constant (within the limits specified under Technical Data on previous page) at the level set by the input command signal. Variations in supply voltage and load resistance have little effect as long as these values satisfy the equality stated below.

$$\text{Maximum Required Currents} \leq \frac{\text{Min. Supply Voltage}}{\text{Max. Load Resistance}}$$

Ordering Information

Contains gasket and mounting screw.

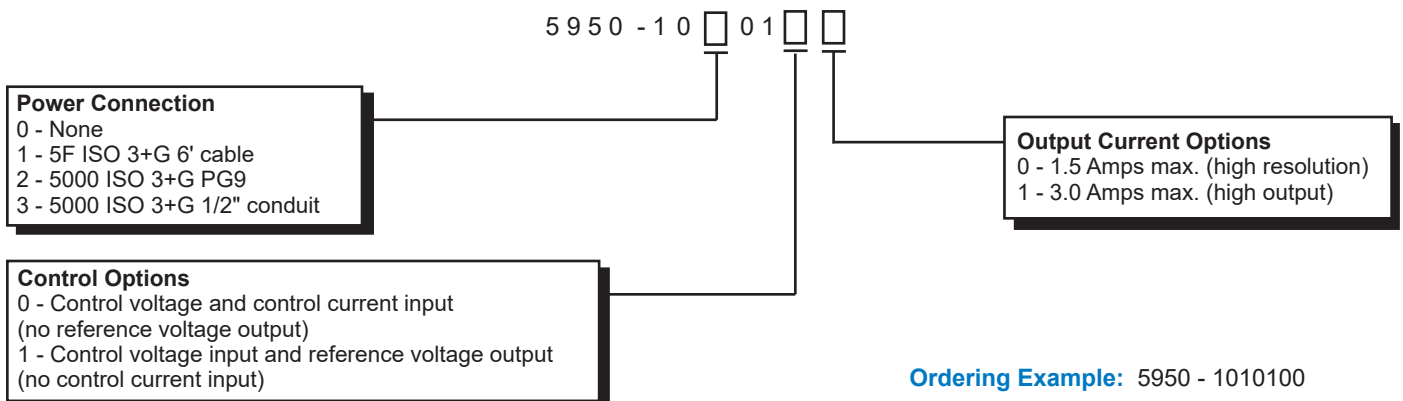

Ordering Example: 5950 - 1010100

5F ISO 3+G 6' cable, control voltage and control current input, 1.5 amps max. output

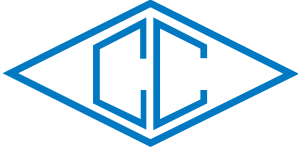

canfield connector
8510 Foxwood Court
Youngstown, Ohio 44514
P:(330) 758-8299 F:(330) 758-8912
www.canfieldconnector.com

B5950 SERIES

BLOCK MICRO PROPORTIONAL DRIVER

General Description

The Canfield Connector B5950 Series is a rugged proportional driver built into an epoxy potted enclosure designed to control linear proportional solenoid operators. Features include selectable control signal inputs from 0-5V or 0-20 mA with adjustable min/max current output. The output steps to the minimum current setting when 0.1V or 0.4 mA is applied to the control signal input. Also included in the compact package is a 0.1 to 20 second adjustable ramp-up and ramp-down output and sine wave dithering (PWM) with adjustable amplitude and frequency. The B5950 has an output current that is proportional to the command signal input.

Dimensional Data

ALL DIMENSIONS ARE IN MILLIMETERS UNLESS OTHERWISE NOTED

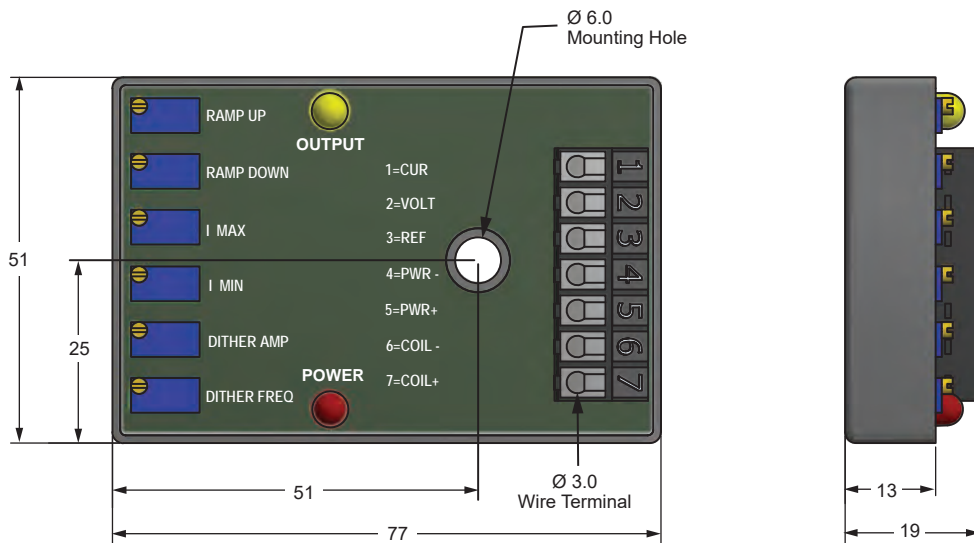

Proportional, Timers
Electronics

Technical Data

Output Current @ 25° C_T Continuous Peak Pulsed (16ms) I min. (+/- 20%) I min. (+/- 20%)	High Resolution Version:	High Output Version:
	1.5 Amps max. 4.7 Amps max. 0 - 0.5 Amps max. I min. + 1.0 Amps max.	3.0 Amps max. 17.0 Amps max. 0 - 1.0 Amps max. I min. + 2.0 Amps max.
Supply Voltage	9 VDC min. - 32 VDC max.	
Supply Current	45 mA max. (no load)	
Input Control Signal Control Voltage Control Current Regulation Δ V Regulation Δ T Ramping Up/Down Time PWM Frequency Output Leap to I min.	0 - 5 VDC (300 Ω impedance)	
	0 - 20 mA (100 Ω impedance)	
	+/- 0.2% / V	
	+/- 0.1% / °C	
	0.1 - 20 sec. linear (+/- 0.1% / °C)	
	1.2 Hz Fixed @ 0.1 V or 0.4 mA control (+/- 15%)	
Dithering Frequency	30-150 Hz	
Dithering Amplitude	0-500 mA Peak to Peak	
Voltage Reference	5.0V +/-5% Regulated	
Temperature Range	-25° to +85°C	
Materials	Housing: ABS Encapsulation: Epoxy	

Function

Minimum Current & Maximum Current - These two adjustments will vary the minimum and maximum output current limits. The minimum current can be set between 0 - 500 mA or 0 - 3 A, depending on output current option. The maximum current can be set in the range between the minimum current setting and the minimum current setting plus 1 A or 2 A depending on output current option. The minimum current must be set first as described below.

Minimum Current Adjustment - Set both min. and max. current adjusters max. counterclockwise. Apply the minimum input command signal (approximately 0.5 volts or 1.0 mA). Adjust the min. current adjuster for a minimum current or to a desired system response. Back up adjuster until system stops responding. Proceed to max. current adjuster.

Maximum Current Adjustment - Increase the input command signal to maximum. Adjust max. current adjuster for a maximum current limit or to a desired system response.

Note: To minimize any effect of supply voltage, load resistance or temperature variation, make setup adjustments when these parameters are at the midpoint of the expected operating range for a particular installation. For example, if the expected operating temperature range is 20° C to 60° C, make final setup adjustments when system is approximately 40° C. If the supply voltage has a tolerance of 22 to 32 volts, make adjustments when the supply voltage is approximately 27 VDC.

$$\text{Maximum Required Currents} \leq \frac{\text{Min. Supply Voltage}}{\text{Max. Load Resistance}}$$

Ramp Up/Ramp Down - Adjust to desired ramp up/ramp down time (0.10 - 20 sec.). Ramp time is linear and is proportional to the step change in the control signal. For example: 0.1 - 5 VDC change in control signal gives max. ramp of 20 sec. 0.1 - 2.5 VDC change in control signal gives max. ramp of 10 sec.

PWM Frequency - The output is pulse-width modulated to control output current within the minimum and maximum current settings. The frequency of the modulation is fixed at 1.2 KHz.

Dither - The coil current is sine wave modulated with adjustable frequency (30 - 150 Hz) and amplitude (0 - .5A peak to peak).

Reference Voltage - A regulated 5.0 VDC voltage is available for on site command voltage. Use of a 10K - 100K potentiometer connected from 5.0 VDC Reference to Supply Voltage (-) is recommended.

Output - The output is current regulated and will remain constant (within the limits specified under Technical Data on previous page) at the level set by the input command signal. Variations in supply voltage and load resistance have little effect as long as these values satisfy the equality stated below.

Ordering Information

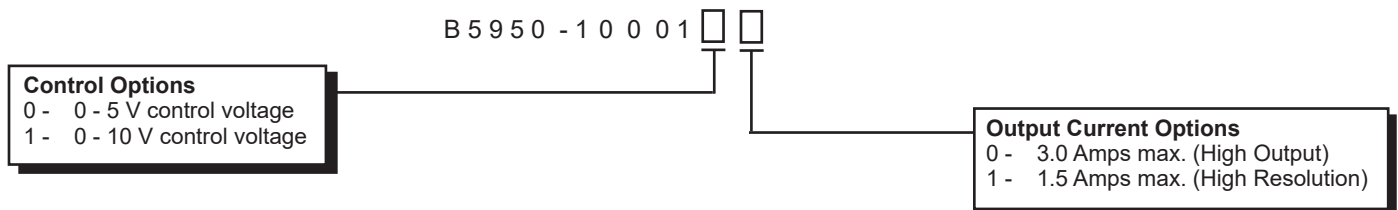

DIN Rail Mounting Adapter
P/N: DRM-100

Ordering Example: B5950 - 1000100

Block Micro Proportional Driver, 0-5V control voltage, 3.0 Amps max

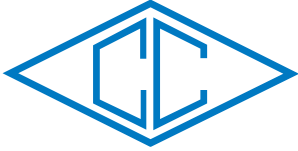

canfield connector
 8510 Foxwood Court
 Youngstown, Ohio 44514
 P:(330) 758-8299 F:(330) 758-8912
 www.canfieldconnector.com

SANDWICH CRT

**CONDENSATION REMOVAL
 TIMER**

General Description

This Canfield Connector miniature timer makes any valve, with the DIN Style "A" EN175301-803 (Formerly DIN 43650) electrical interface, able to operate as a compressed air system condensate removal valve. The unit installs in a modular form between an existing coil and connector. No new wiring is necessary. Retrofits on virtually any installation. It works with the valve brand of your choice. The cycle and on times are easily adjustable and two indicator lights show status.

Dimensional Data

ALL DIMENSIONS ARE IN MILLIMETERS UNLESS OTHERWISE NOTED

Proportional, Timers
Electronics

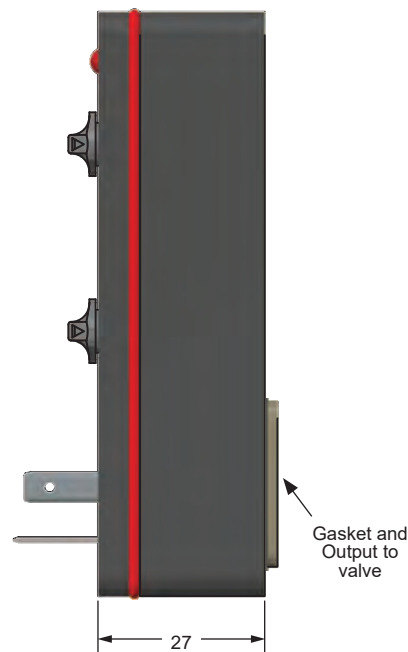
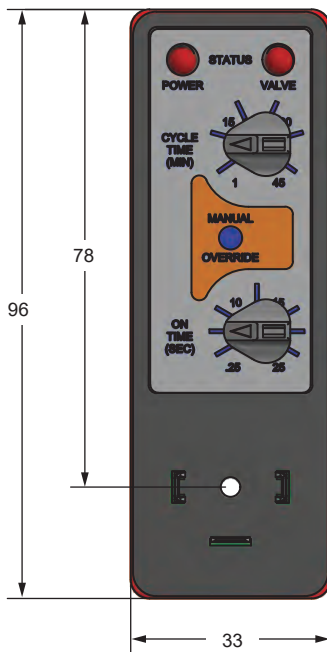
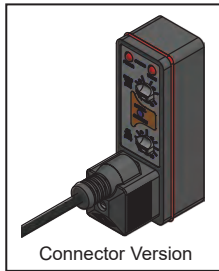

Consult factory for available versions listed by Canadian Standards Association for use with certified electrical equipment.

Timer Function

TIMER FUNCTION

Upon application of power to the input terminals, the OFF time is initiated. At the end of the preset CYCLE time, the solenoid is energized and the ON time begins. At the end of the preset ON time, power is removed from the solenoid and a new cycle begins. Cycling continues until power is removed from the input terminals.

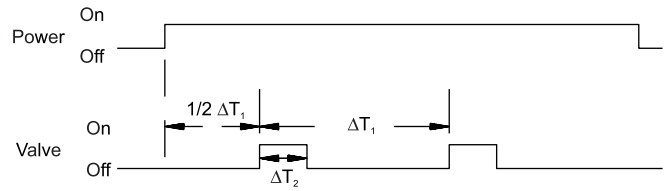

ΔT_1 = Cycle Rate (1 min. to 45 min.)
 ΔT_2 = Valve ON Time (.25 sec. to 25 sec.)

Technical Data

Voltage Range	12-60 VDC, 12-240 VAC 50/60 Hz
Max. Output Current	1 Amp AC, 1Amp DC
Transient Suppression	AC - MOV DC - Diode
Materials	Housing: PA
Temp. Range	-20° to +65°C
Environmental Protection	IP 65 and NEMA 4 (When properly installed)
Size	ISO: 18mm pin spacing - DIN Style "A" EN175301-803

Ordering Information

Contains gasket and mounting screw.

5 9 4 0 - 0 0 0

Power Connection

- 0 - None
- 1 - 5F ISO 2+G 6' cable with 120V plug
- 2 - 5000 ISO 2+G 1/2" conduit
- 3 - 5F ISO 2+G 6' cable

Voltage Range

- 2 - 12 - 60 VDC
- 4 - 12 - 120 VAC
- 5 - 120 - 240 VAC

Ordering Example: 5940 - 10005
 Sandwich Timer (CRT), 5F ISO 2+G
 6' cable, 120 to 240 VAC

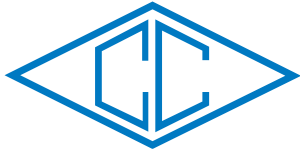

canfield connector
 8510 Foxwood Court
 Youngstown, Ohio 44514
 P:(330) 758-8299 F:(330) 758-8912
 www.canfieldconnector.com

MBT

**MULTIFUNCTION BLOCK TIMER
 12 FUNCTIONS IN 1 TIMER**

General Description

The Canfield Connector model MBT Multifunction Block Timer is designed as a full featured, multiple voltage, all-in-one programmable timer. It can be operated individually or cascaded to perform virtually any timing sequence desired. The unit has a time range adjustable from 0.1 seconds to 33.3 hours. Features include twelve modes of operation including a multitude of logic function possibilities and an indicator light for fast troubleshooting along with single turn timing adjustment. The MBT can instantly handle all mobile, industrial and automation applications right off the shelf.

Dimensional Data

ALL DIMENSIONS ARE IN MILLIMETERS UNLESS OTHERWISE NOTED

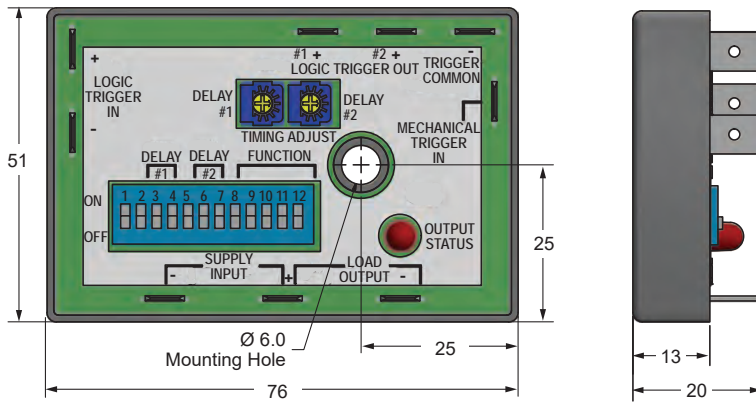

Proportional Timers Electronics

Hook-Up

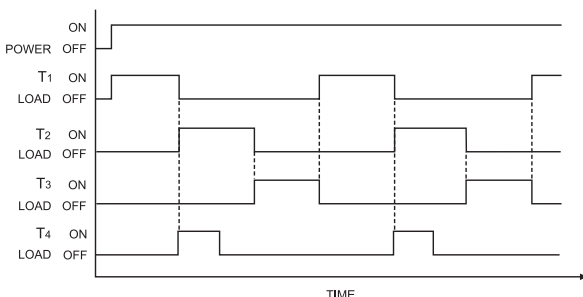
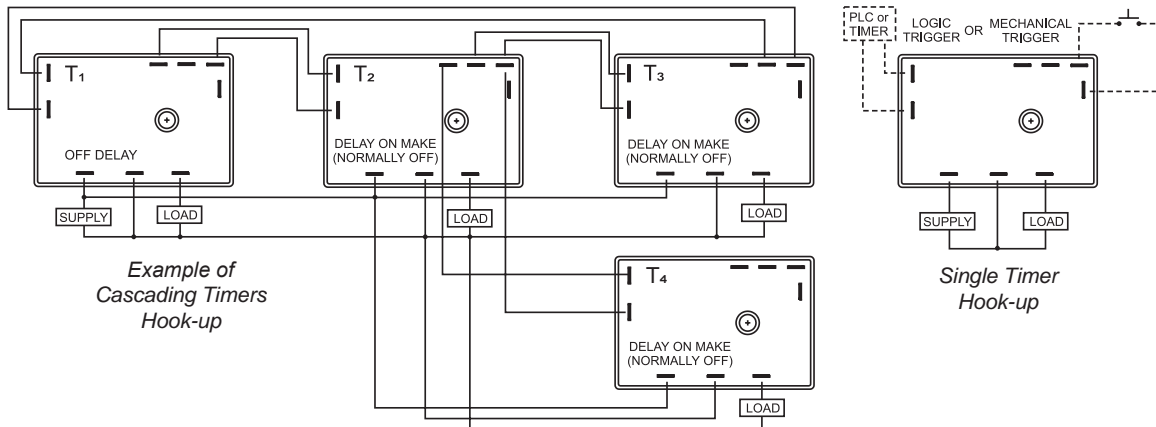

Consult factory for available versions listed by Canadian Standards Association for use with certified electrical equipment.

Technical Data

Input Voltage Range	12-240 VDC, 24-240 VAC (50/60 Hz)
Max. Output Current	1 Amp
Logic Trigger In	5-48 VDC (10k Input impedance)
Logic Trigger Out	5.5 V @ .55mA Max.
Mechanical Trigger In	80mA Max. Current draw
Transient Suppression	AC - MOV DC - Diode
Reset Time Max.	50ms
Repeat Accuracy	+/-0.1% or 10ms (whichever is greater)
Time Delay	+/-2% Variable over ambient temperature range
Ambient Temp. Range	-20° to +60°C
Materials	Housing: ABS Encapsulation: Epoxy
Environmental Protection	NEMA 1

Timer Programming

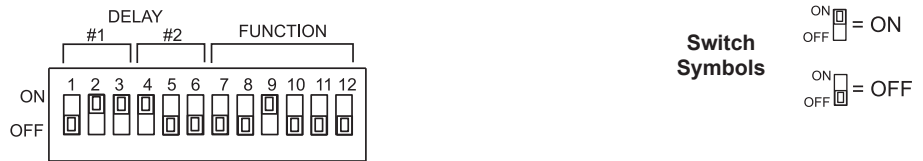

Chart 1	
#1 Delay Range (seconds) All Function	Switch Settings
.10 - 4.70	ON <input type="checkbox"/> 1 <input type="checkbox"/> 2 OFF <input type="checkbox"/> 1 <input type="checkbox"/> 2
0.36 - 18.0	ON <input type="checkbox"/> 1 <input type="checkbox"/> 2 OFF <input type="checkbox"/> 1 <input type="checkbox"/> 2
2.80 - 150	ON <input type="checkbox"/> 1 <input type="checkbox"/> 2 OFF <input type="checkbox"/> 1 <input type="checkbox"/> 2
23.0 - 1200	ON <input type="checkbox"/> 1 <input type="checkbox"/> 2 OFF <input type="checkbox"/> 1 <input type="checkbox"/> 2
Delay = range X 1	ON <input type="checkbox"/> 3 OFF <input type="checkbox"/> 3
Delay = range X 100	ON <input type="checkbox"/> 3 OFF <input type="checkbox"/> 3

Chart 2	
#2 Delay Range (seconds) Cycle Function Only	Switch Settings
0.10 - 4.70	ON <input type="checkbox"/> 4 <input type="checkbox"/> 5 OFF <input type="checkbox"/> 4 <input type="checkbox"/> 5
0.36 - 18.0	ON <input type="checkbox"/> 4 <input type="checkbox"/> 5 OFF <input type="checkbox"/> 4 <input type="checkbox"/> 5
2.80 - 150	ON <input type="checkbox"/> 4 <input type="checkbox"/> 5 OFF <input type="checkbox"/> 4 <input type="checkbox"/> 5
23.0 - 1200	ON <input type="checkbox"/> 4 <input type="checkbox"/> 5 OFF <input type="checkbox"/> 4 <input type="checkbox"/> 5
Delay = range X 1	ON <input type="checkbox"/> 6 OFF <input type="checkbox"/> 6
Delay = range X 100	ON <input type="checkbox"/> 6 OFF <input type="checkbox"/> 6

Chart 3	
Function	Switch Settings
#1 Off delay (retriggerable)	ON <input type="checkbox"/> 7 <input type="checkbox"/> 8 <input type="checkbox"/> 9 <input type="checkbox"/> 10 <input type="checkbox"/> 11 <input type="checkbox"/> 12 OFF <input type="checkbox"/> 7 <input type="checkbox"/> 8 <input type="checkbox"/> 9 <input type="checkbox"/> 10 <input type="checkbox"/> 11 <input type="checkbox"/> 12
#2 On delay (retriggerable)	ON <input type="checkbox"/> 7 <input type="checkbox"/> 8 <input type="checkbox"/> 9 <input type="checkbox"/> 10 <input type="checkbox"/> 11 <input type="checkbox"/> 12 OFF <input type="checkbox"/> 7 <input type="checkbox"/> 8 <input type="checkbox"/> 9 <input type="checkbox"/> 10 <input type="checkbox"/> 11 <input type="checkbox"/> 12
#3a Cycle (on first)	ON <input type="checkbox"/> 7 <input type="checkbox"/> 8 <input type="checkbox"/> 9 <input type="checkbox"/> 10 <input type="checkbox"/> 11 <input type="checkbox"/> 12 OFF <input type="checkbox"/> 7 <input type="checkbox"/> 8 <input type="checkbox"/> 9 <input type="checkbox"/> 10 <input type="checkbox"/> 11 <input type="checkbox"/> 12
#3b Cycle (off first)	ON <input type="checkbox"/> 7 <input type="checkbox"/> 8 <input type="checkbox"/> 9 <input type="checkbox"/> 10 <input type="checkbox"/> 11 <input type="checkbox"/> 12 OFF <input type="checkbox"/> 7 <input type="checkbox"/> 8 <input type="checkbox"/> 9 <input type="checkbox"/> 10 <input type="checkbox"/> 11 <input type="checkbox"/> 12
#4a Square wave (on first)	ON <input type="checkbox"/> 7 <input type="checkbox"/> 8 <input type="checkbox"/> 9 <input type="checkbox"/> 10 <input type="checkbox"/> 11 <input type="checkbox"/> 12 OFF <input type="checkbox"/> 7 <input type="checkbox"/> 8 <input type="checkbox"/> 9 <input type="checkbox"/> 10 <input type="checkbox"/> 11 <input type="checkbox"/> 12
#4b Square wave (off first)	ON <input type="checkbox"/> 7 <input type="checkbox"/> 8 <input type="checkbox"/> 9 <input type="checkbox"/> 10 <input type="checkbox"/> 11 <input type="checkbox"/> 12 OFF <input type="checkbox"/> 7 <input type="checkbox"/> 8 <input type="checkbox"/> 9 <input type="checkbox"/> 10 <input type="checkbox"/> 11 <input type="checkbox"/> 12
#5 Delay on break (normally off)	ON <input type="checkbox"/> 7 <input type="checkbox"/> 8 <input type="checkbox"/> 9 <input type="checkbox"/> 10 <input type="checkbox"/> 11 <input type="checkbox"/> 12 OFF <input type="checkbox"/> 7 <input type="checkbox"/> 8 <input type="checkbox"/> 9 <input type="checkbox"/> 10 <input type="checkbox"/> 11 <input type="checkbox"/> 12
#6 Delay on break (normally on)	ON <input type="checkbox"/> 7 <input type="checkbox"/> 8 <input type="checkbox"/> 9 <input type="checkbox"/> 10 <input type="checkbox"/> 11 <input type="checkbox"/> 12 OFF <input type="checkbox"/> 7 <input type="checkbox"/> 8 <input type="checkbox"/> 9 <input type="checkbox"/> 10 <input type="checkbox"/> 11 <input type="checkbox"/> 12
#7 Delay on make (normally off)	ON <input type="checkbox"/> 7 <input type="checkbox"/> 8 <input type="checkbox"/> 9 <input type="checkbox"/> 10 <input type="checkbox"/> 11 <input type="checkbox"/> 12 OFF <input type="checkbox"/> 7 <input type="checkbox"/> 8 <input type="checkbox"/> 9 <input type="checkbox"/> 10 <input type="checkbox"/> 11 <input type="checkbox"/> 12
#8 Delay on make (normally on)	ON <input type="checkbox"/> 7 <input type="checkbox"/> 8 <input type="checkbox"/> 9 <input type="checkbox"/> 10 <input type="checkbox"/> 11 <input type="checkbox"/> 12 OFF <input type="checkbox"/> 7 <input type="checkbox"/> 8 <input type="checkbox"/> 9 <input type="checkbox"/> 10 <input type="checkbox"/> 11 <input type="checkbox"/> 12
#9a Toggle (on first)	ON <input type="checkbox"/> 7 <input type="checkbox"/> 8 <input type="checkbox"/> 9 <input type="checkbox"/> 10 <input type="checkbox"/> 11 <input type="checkbox"/> 12 OFF <input type="checkbox"/> 7 <input type="checkbox"/> 8 <input type="checkbox"/> 9 <input type="checkbox"/> 10 <input type="checkbox"/> 11 <input type="checkbox"/> 12
#9b Toggle (off first)	ON <input type="checkbox"/> 7 <input type="checkbox"/> 8 <input type="checkbox"/> 9 <input type="checkbox"/> 10 <input type="checkbox"/> 11 <input type="checkbox"/> 12 OFF <input type="checkbox"/> 7 <input type="checkbox"/> 8 <input type="checkbox"/> 9 <input type="checkbox"/> 10 <input type="checkbox"/> 11 <input type="checkbox"/> 12

Operation

Mechanical Trigger Input - A switch closure at this input begins or resets the timing period of any non-cycling MBT function.

Logic Trigger Input - A sourcing or sinking voltage signal (5 - 48 volts) at this input begins or resets the timing period of any non-cycling MBT function.

Logic Trigger Outputs - The logic output produces a voltage signal in sync with the timing cycle. Timers can be cascaded when the logic output of one timer is connected to the logic input of other timers.

The logic signal output is inactive when power is initially applied to the timer. The #1 logic output produces a voltage level opposite the #2 logic output.

Cascading Multiple Timers - There is no limit to the number of MBTs that can be cascaded in series (the logic output of one MBT connected to the logic input of another MBT). However the number of parallel MBTs (the same logic output connected to the logic input of more than one other MBT) should be limited to 10 MBTs.

FUNCTION #1

Load is energized for ΔT upon application of power. Reset occurs when power is removed or trigger is applied.

Off Delay (Retriggerable)

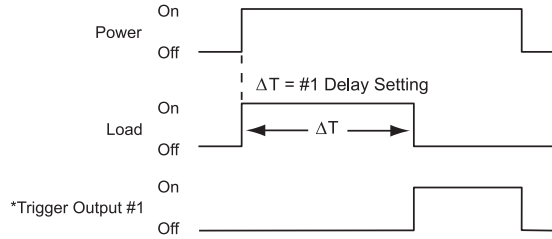

FUNCTION #2

Load remains Off for ΔT upon application of power. Reset occurs when power is removed or trigger is applied.

On Delay (Retriggerable)

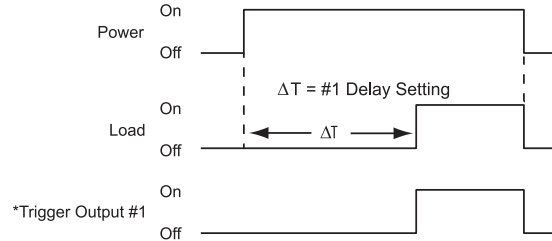

FUNCTION #3a / 3b

Load cycles ΔT_1 and ΔT_2 when power is applied. Reset occurs when power is removed.

Cycle

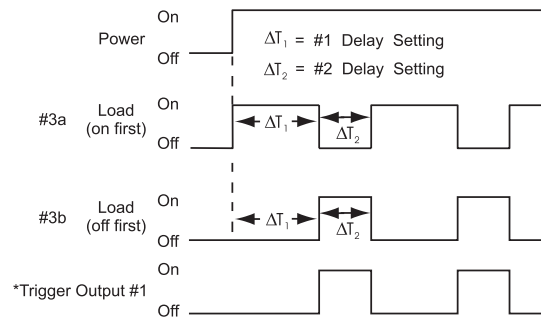

FUNCTION #4a / 4b

Load cycles with equal On and Off times when power is applied. Reset occurs when power is removed.

Square Wave

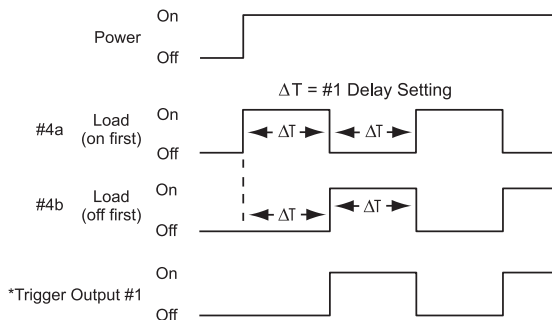

FUNCTION #5

When power is applied, load remains Off. Load is energized when trigger switch is closed. When trigger switch is opened, ΔT begins. The load de-energizes at completion of ΔT . Reset occurs when load is Off and trigger is re-applied.

Delay On Break (Normally Off)

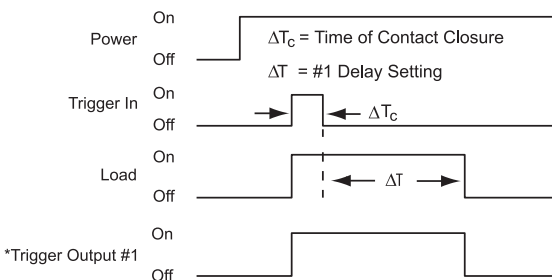

NOTE: Refer to charts on page 103 for switch settings.

*Trigger Output #2 level is always opposite of Trigger Output #1.

FUNCTION #6

When power is applied, load is energized and remains energized until the trigger switch is closed. Load is then Off for $\Delta T_c + \Delta T$. Reset occurs when load is On and the trigger is re-applied.

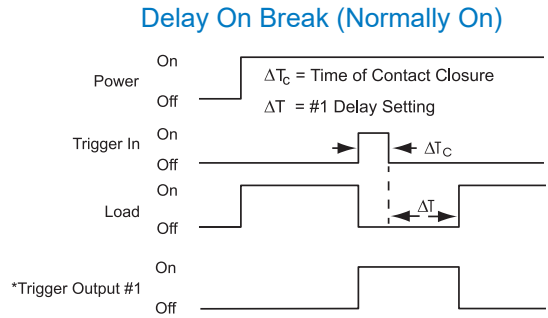

FUNCTION #7

When power is applied, load remains Off. Load is energized for ΔT only upon closure of a normally open momentary contact switch (trigger). Reset occurs when load is Off and the trigger switch is closed.

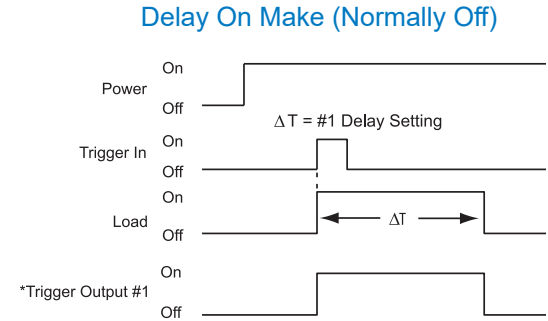

FUNCTION #8

When power is applied, load is energized. Load de-energizes for ΔT only upon closure of a normally open momentary contact switch (trigger). Reset occurs when load is On and the trigger switch is closed.

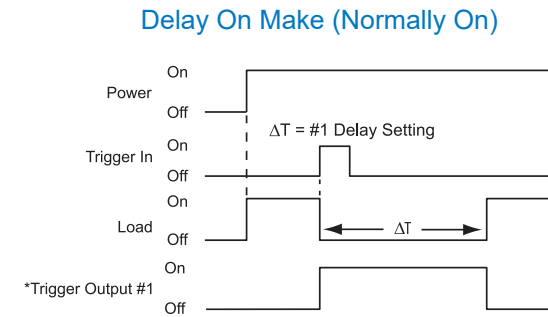

FUNCTION #9a / 9b

When power is applied, load is On. Load switches state (On/Off) with each application of trigger

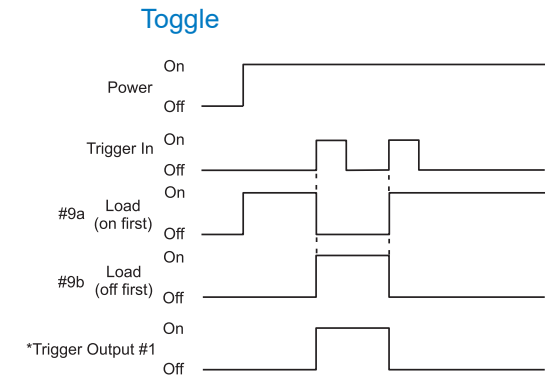

NOTE: Refer to charts on page 103 for switch settings.

*Trigger Output #2 level is always opposite of Trigger Output #1.

Ordering Information



DIN Rail Mounting Adapter
P/N: DRM-100

ORDER PART NUMBER
MBT-1000-00

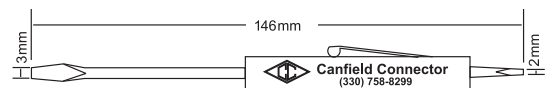

Optional Adjustment Tool
P/N: 5000-TOOL

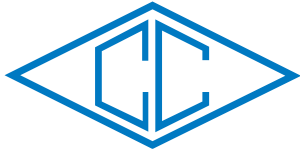

canfield connector
8510 Foxwood Court
Youngstown, Ohio 44514
P:(330) 758-8299 F:(330) 758-8912
www.canfieldconnector.com

TMLT

MICROLOGIC TIMER MODULE

General Description

The Canfield Connector TMLT is an ultra-compact all solid state timer incorporated into a vibration and environment resistant composite encapsulant housing. The heart of the timer is a powerful microprocessor that is made in quantity then programmed to become the timer type according to customer specification. Featuring 6 timer modes of operation with two voltage ranges; 12-240V AC/DC or 12-60 VDC and four output options; Sinking ON First, Sinking OFF First, Sourcing ON First, and Sourcing OFF First, and 13 time ranges, from 0.1 to 2000 seconds. The timer is available with screwdriver or hand adjustment, and troubleshooting is a breeze with the onboard indicator light. The TMLT is versatile as well as rugged, and each timer is 100% tested, made in America and resistant to dust, vibration and humidity. Mounting is accomplished by use of a through hole able to accommodate up to a 1/4" (6mm) screw or by use of a DIN rail mount adapter plate. Electrical connections are .250" AMP Faston posts for crimp type push-on connectors.

Dimensional Data

ALL DIMENSIONS ARE IN MILLIMETERS UNLESS OTHERWISE NOTED

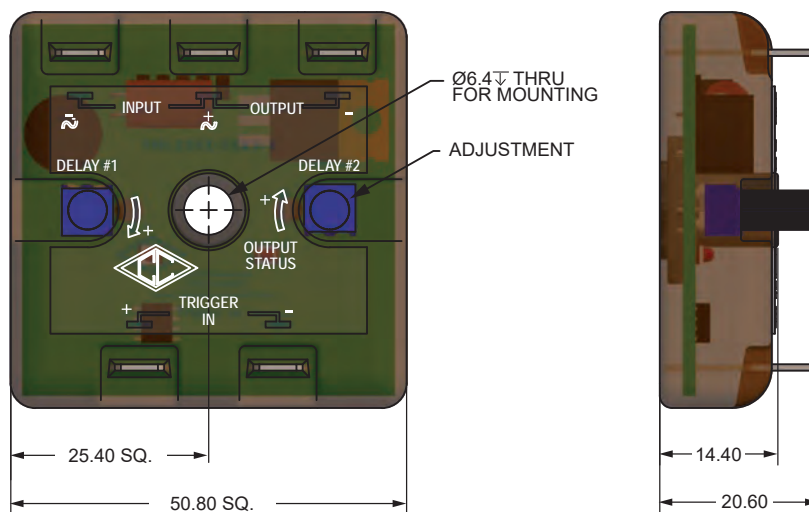
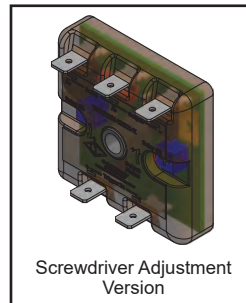
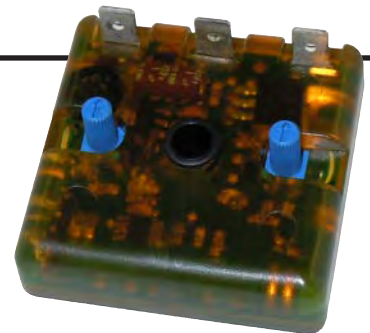

Proportional Timers
Electronics

Technical Data

Max. Timer Current Draw	2 mA (no load)
Output Current Max.	1 Amp
Input Voltage Range	12-240V AC/DC, 50/60 Hz or 12-60 VDC
Logic Trigger Rated	5-48 VDC (10k input impedance)
Mechanical Trigger Rated	5 VDC, 1 mA max.
Repeat Accuracy	+/- 0.1% or 10ms (whichever is greater)
Time Delay	+/- 5% (Variable over ambient temp. range)
Materials	Enclosure: Macromelt Thermoplastic Polyamide
Temp. Range	-20° to +60°C
Environmental Protection	NEMA 1

Timing Diagrams / Ordering Guide

SQUARE WAVE

Load cycles with equal ΔT_1 time when power is applied. Reset occurs when power is removed.

How To Order

TMLTSW - 00

ΔT_1

Voltage / Output Type

1 - 12-240V AC/DC / Sinking / On first
 2 - 12-240V AC/DC / Sinking / Off first
 3 - 12-60V DC / Sinking / On First
 4 - 12-60V DC / Sinking / Off First
 5 - 12-60V DC / Sourcing / On First
 6 - 12-60V DC / Sourcing / OFF First

Adjustable Potentiometer

0 - Screw Adjust
 1 - Hand Adjust

Time Range

A - 0.5 to 5 sec.	H - 5.0 to 50 sec.
B - 0.5 to 25 sec.	I - 5.0 to 500 sec.
C - 0.5 to 50 sec.	J - 10 to 100 sec.
D - 0.5 to 100 sec.	K - 10 to 1000 sec.
E - 2.0 to 20 sec.	L - 10 to 2000 sec.
F - 2.0 to 200 sec.	Z - 0.1 to 5 sec.
G - 2.0 to 400 sec.	

CYCLE

Load cycles ΔT_1 and ΔT_2 when power is applied. Reset occurs when power is removed.

How To Order

TMLTCY - 0

ΔT_1 ΔT_2

Voltage / Output Type

1 - 12-240V AC/DC / Sinking / On first
 2 - 12-240V AC/DC / Sinking / Off first
 3 - 12-60V DC / Sinking / On First
 4 - 12-60V DC / Sinking / Off First
 5 - 12-60V DC / Sourcing / On First
 6 - 12-60V DC / Sourcing / OFF First

Adjustable Potentiometer

0 - Screw Adjust
 1 - Hand Adjust

Time Range

A - 0.5 to 5 sec.	H - 5.0 to 50 sec.
B - 0.5 to 25 sec.	I - 5.0 to 500 sec.
C - 0.5 to 50 sec.	J - 10 to 100 sec.
D - 0.5 to 100 sec.	K - 10 to 1000 sec.
E - 2.0 to 20 sec.	L - 10 to 2000 sec.
F - 2.0 to 200 sec.	Z - 0.1 to 5 sec.
G - 2.0 to 400 sec.	

Proportional, Timers
Electronics

107

DELAY ON MAKE

When power is applied, load is on. Load is off for ΔT_1 once the trigger is applied. Reset occurs when load is on and the trigger is re-applied.

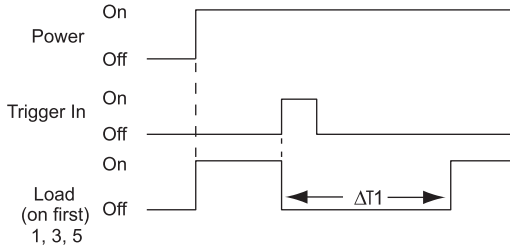

When power is applied, load is off. Load is on for ΔT_1 once the trigger is applied. Reset occurs when load is on and the trigger is re-applied.

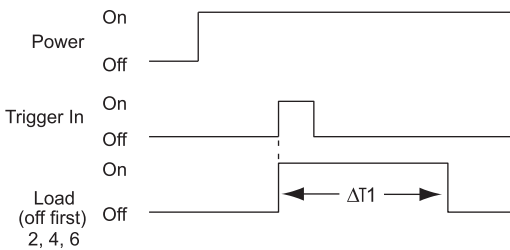

How To Order

TMLTDM - 0
 ΔT_1

Voltage / Output Type
 1 - 12-240V AC/DC / Sinking / On first
 2 - 12-240V AC/DC / Sinking / Off first
 3 - 12-60V DC / Sinking / On First
 4 - 12-60V DC / Sinking / Off First
 5 - 12-60V DC / Sourcing / On First
 6 - 12-60V DC / Sourcing / OFF First

Adjustable Potentiometer
 0 - Screw Adjust
 1 - Hand Adjust

Trigger Option
 1 - 5-48 Volt Trigger
 2 - Mechanical Trigger

Time Range
 A - 0.5 to 5 sec. H - 5.0 to 50 sec.
 B - 0.5 to 25 sec. I - 5.0 to 500 sec.
 C - 0.5 to 50 sec. J - 10 to 100 sec.
 D - 0.5 to 100 sec. K - 10 to 1000 sec.
 E - 2.0 to 20 sec. L - 10 to 2000 sec.
 F - 2.0 to 200 sec. Z - 0.1 to 5 sec.
 G - 2.0 to 400 sec.

DELAY ON BREAK

When power is applied, load is on. Load is then off for $\Delta T_c + \Delta T_1$ when trigger is applied then removed. Reset occurs when load is on and the trigger is re-applied.

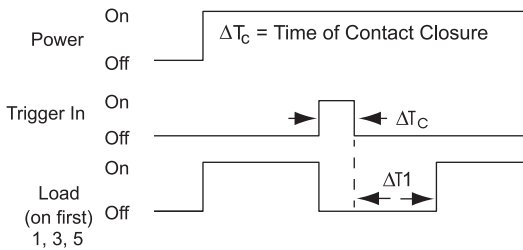

When power is applied, load is off. Load is on for $\Delta T_c + \Delta T_1$ when trigger is applied then removed. Reset occurs when load is on and the trigger is re-applied.

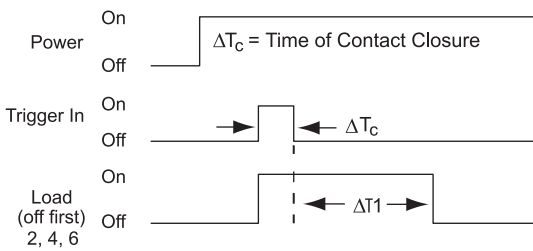

How To Order

TMLTDB - 0
 ΔT_1

Voltage / Output Type
 1 - 12-240V AC/DC / Sinking / On first
 2 - 12-240V AC/DC / Sinking / Off first
 3 - 12-60V DC / Sinking / On First
 4 - 12-60V DC / Sinking / Off First
 5 - 12-60V DC / Sourcing / On First
 6 - 12-60V DC / Sourcing / OFF First

Adjustable Potentiometer
 0 - Screw Adjust
 1 - Hand Adjust

Trigger Option
 1 - 5-48 Volt Trigger
 2 - Mechanical Trigger

Time Range
 A - 0.5 to 5 sec. H - 5.0 to 50 sec.
 B - 0.5 to 25 sec. I - 5.0 to 500 sec.
 C - 0.5 to 50 sec. J - 10 to 100 sec.
 D - 0.5 to 100 sec. K - 10 to 1000 sec.
 E - 2.0 to 20 sec. L - 10 to 2000 sec.
 F - 2.0 to 200 sec. Z - 0.1 to 5 sec.
 G - 2.0 to 400 sec.

When power is applied, load is off. Load on after ΔT_1 . Reset occurs when power is removed

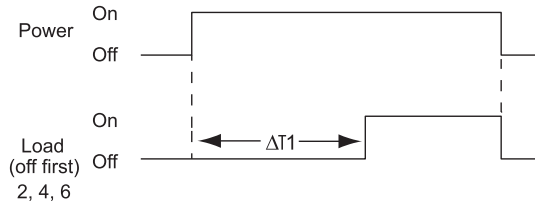

When power is applied, load is on. Load off after ΔT_1 . Reset occurs when power is removed

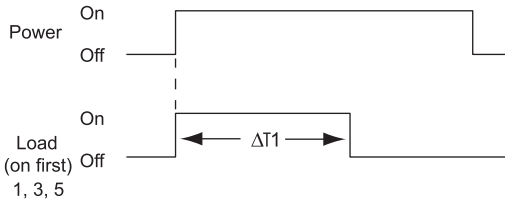

How To Order

TMLTDY - 00
 ΔT_1

Voltage / Output Type
 1 - 12-240V AC/DC / Sinking / On first
 2 - 12-240V AC/DC / Sinking / Off first
 3 - 12-60V DC / Sinking / On First
 4 - 12-60V DC / Sinking / Off First
 5 - 12-60V DC / Sourcing / On First
 6 - 12-60V DC / Sourcing / OFF First

Adjustable Potentiometer
 0 - Screw Adjust
 1 - Hand Adjust

Time Range
 A - 0.5 to 5 sec. H - 5.0 to 50 sec.
 B - 0.5 to 25 sec. I - 5.0 to 500 sec.
 C - 0.5 to 50 sec. J - 10 to 100 sec.
 D - 0.5 to 100 sec. K - 10 to 1000 sec.
 E - 2.0 to 20 sec. L - 10 to 2000 sec.
 F - 2.0 to 200 sec. G - 2.0 to 400 sec. Z - 0.1 to 5 sec.

Solenoid cycles ΔT_1 and ΔT_2 when power is applied. Reset occurs when power is removed.

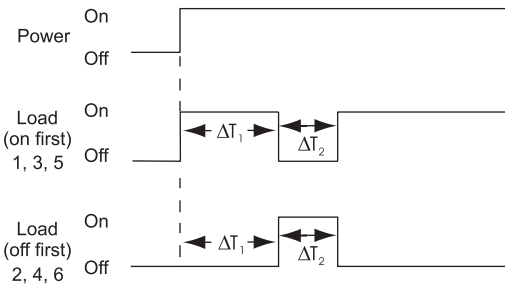

How To Order

TMLTSC - 0
 ΔT_1 ΔT_2

Voltage / Output Type
 1 - 12-240V AC/DC / Sinking / On first
 2 - 12-240V AC/DC / Sinking / Off first
 3 - 12-60V DC / Sinking / On First
 4 - 12-60V DC / Sinking / Off First
 5 - 12-60V DC / Sourcing / On First
 6 - 12-60V DC / Sourcing / OFF First

Adjustable Potentiometer
 0 - Screw Adjust
 1 - Hand Adjust

Time Range
 A - 0.5 to 5 sec. H - 5.0 to 50 sec.
 B - 0.5 to 25 sec. I - 5.0 to 500 sec.
 C - 0.5 to 50 sec. J - 10 to 100 sec.
 D - 0.5 to 100 sec. K - 10 to 1000 sec.
 E - 2.0 to 20 sec. L - 10 to 2000 sec.
 F - 2.0 to 200 sec. G - 2.0 to 400 sec. Z - 0.1 to 5 sec.

NOTE: Fixed and custom time ranges available. Consult factory or details.



DIN Rail Mounting Adapter
 P/N: DRM-100

Ordering Example: TMLTSC1-AB00

12-240 AC/DC, Sinking, Single
 Cycle 1 (on first), 0.5 to 5 sec.,
 0.5 to 25 sec., Screw Adjust.

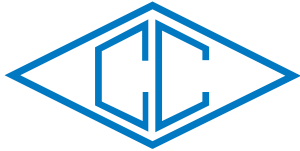

OSV

**OPTICAL SENSOR VALVE
 PHOTO-EYE ACCUMULATION SYSTEM**

General Description

The Canfield Connector Model OSV is a fully-modular, easily-installable, optical sensor and valve combination for conveyor automation. This unit is designed for sensing objects moving through conveyor zones in order to maximize product flow while preventing product damage. By incorporating solid-state electronics and a low wattage solenoid valve, the OSV uses logic and manual inputs to reliably control a pneumatic actuator. The actuator either extends or retracts, controlling the movement of the conveyor zone. Features include adjustable sensitivity and output delay with LEDs to facilitate troubleshooting and a visual display of sensor modes. The modular design allows easy component replacement.

Dimensional Data

ALL DIMENSIONS ARE IN MILLIMETERS UNLESS OTHERWISE NOTED

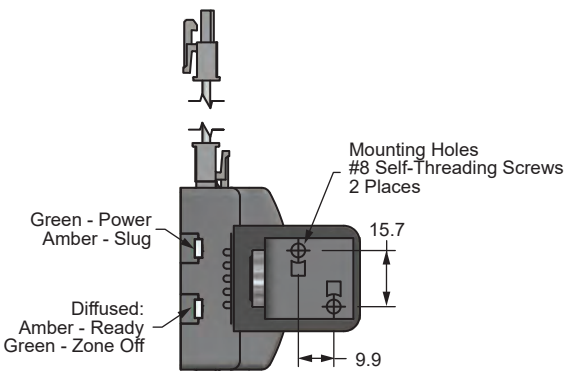
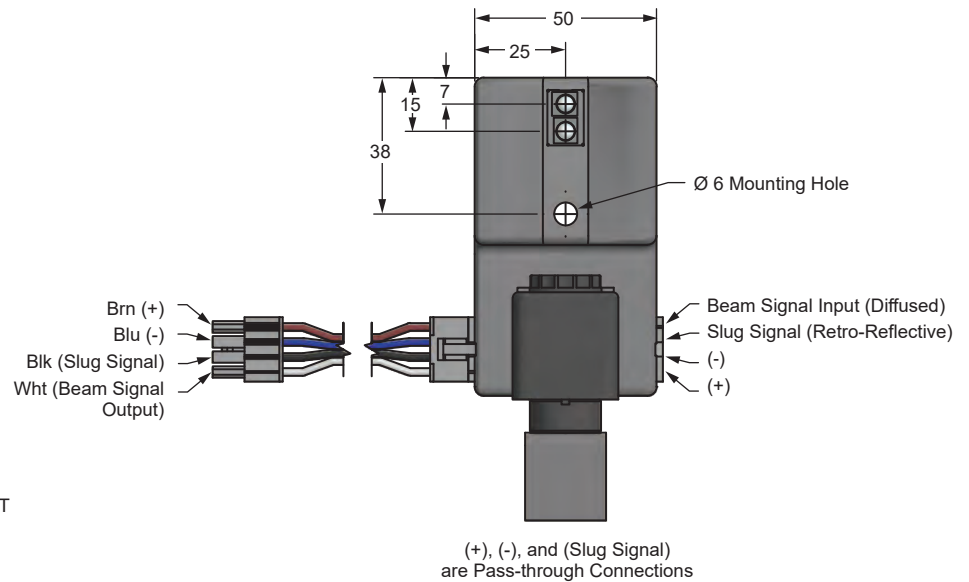
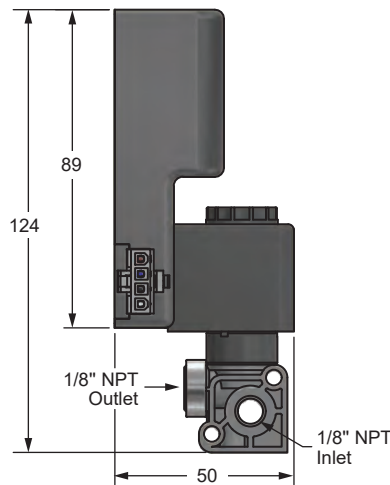
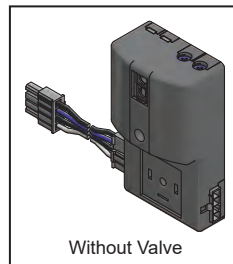
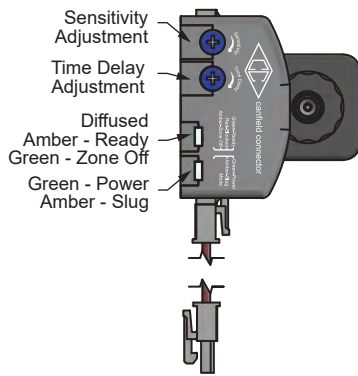

Conveyor Controls



Consult factory for available versions listed by Canadian Standards Association for use with certified electrical equipment.

Technical Data

Supply Voltage	20-28 VDC
Supply Current	65 mA with 0.9W coil energized
Slug Signal (Input)	12µA Max. per sensor sinking (NPN), (retro-reflective)
Beam Signal (Input)	5mA Max. sourcing (PNP) (diffused)
Beam Signal (Output)	200mA Max. sinking (NPN)80mA Max. Current draw
Sensing Distance	6 ft.
Valve Orifice / Pressure	1.0mm / 0 - 30 psi
Valve Time Delay	0.02 - 3 sec.
Valve Type	Normally Closed
Operating Temp.	-10° to +50°C
Materials	Housing: ABS
Environmental Protection	NEMA 1

Retro-Reflective Accumulation

Retro-Reflective Accumulation

Normally Open Operation

When Beam is CLEAR (no object detected)

- 1) Status LED is GREEN
- 2) Valve is OPEN
- 3) Beam Signal is ON (sinking 200mA max)

When Beam is BLOCKED (object detected)

- 1) Status LED turn RED for the set amount of time delay (0.02 - 3sec) then turns AMBER
- 2) Valve CLOSES after the set time delay
- 3) Beam Signal turns off immediately (no time delay)
- 4) If an override is needed, a GND signal to the Slug Input will OPEN all valves connected inline

Normally Closed Operation

When Beam is CLEAR (no object detected)

- 1) Status LED is GREEN
- 2) Valve is CLOSED
- 3) Beam Signal is ON (sinking 200mA max)

When Beam is BLOCKED (object detected)

- 1) Status LED turn RED for the set amount of time delay (0.02 - 3sec) then turns AMBER
- 2) Valve OPENS after the set time delay
- 3) Beam Signal turns off immediately (no time delay)
- 4) If an override is needed, a GND signal to the Slug Input will CLOSE all valves connected inline

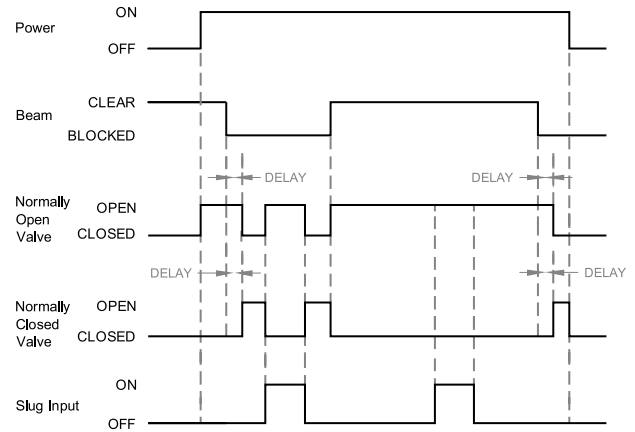

Diffused Accumulation (no time delay or slug)

Diffused Accumulation

Normally Open Operation

When Beam is CLEAR (no object detected)

- 1) Status LED is AMBER
- 2) Valve is OPEN
- 3) Beam Signal is ON (sinking 200mA max)

When Beam is BLOCKED (object detected)

- 1) Status LED is GREEN (no time delay)
- 2) Valve is CLOSED (no time delay)
- 3) Beam Signal turns off immediately (no time delay)

Normally Closed Operation

When Beam is CLEAR (no object detected)

- 1) Status LED is AMBER
- 2) Valve is CLOSED
- 3) Beam Signal is ON (sinking 200mA max)

When Beam is BLOCKED (object detected)

- 1) Status LED is GREEN (no time delay)
- 2) Valve is OPEN (no time delay)
- 3) Beam Signal turns off immediately (no time delay)

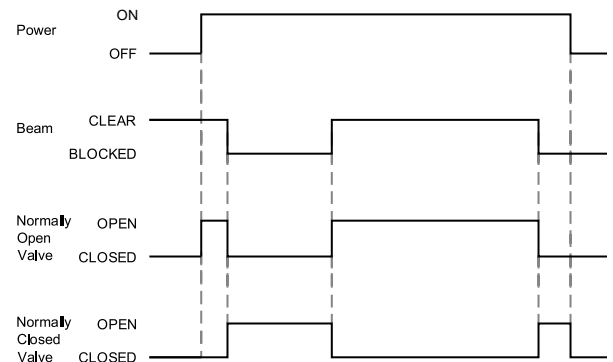

*Beam Status Signal follows the pattern as the Beam itself. When the Beam is clear the Beam Status Signal is ON.

Retro-Reflective Indexing Normally Closed

Retro-Reflective Indexing

Normally Closed Operation

- Downstream Sensor Beam is CLEAR (no object detected)
- 1) Downstream Sensor Status LED is GREEN
 - 2) Downstream Sensor valve is CLOSED
 - 3) Downstream Sensor Beam Signal is LOW providing a CLEAR signal to the Upstream sensor
 - 4) Upstream Sensor valve is CLOSED no matter if its beam is CLEAR or BLOCKED
- Downstream Sensor Beam is BLOCKED (object detected)
- 1) Downstream Sensor Status LED turns RED for the set time delay (0.02 - 3sec) then turns AMBER
 - 2) Downstream Sensor valve OPENS after the set time delay
 - 3) Downstream Sensor Beam Signal immediately changes HIGH (no time delay), providing a BLOCKED signal to the Upstream Sensor
 - 4) Upstream Sensor valve is CLOSED until its Beam is BLOCKED
 - 5) If both Downstream and Upstream sensors are BLOCKED their valves will be OPEN
 - 6) If an override is needed, a GND signal to the Slug Input will CLOSE all valves connected inline

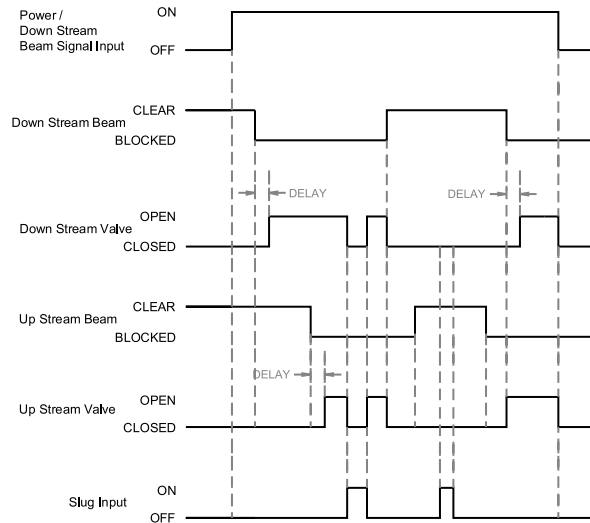

Diffused Indexing Normally Closed (no time delay or slug)

Diffused Indexing

Normally Closed Operation

- Downstream Sensor Beam is CLEAR (no object detected)
- 1) Downstream Sensor status LED is AMBER
 - 2) Downstream Sensor valve is CLOSED
 - 3) Downstream Sensor Beam Signal is LOW, providing a CLEAR signal to the Upstream sensor
 - 4) Upstream Sensor valve is CLOSED no matter if its beam is CLEAR or BLOCKED
- Downstream Sensor Beam is BLOCKED (object detected)
- 1) Downstream Sensor Status LED turns GREEN (no time delay)
 - 2) Downstream Sensor valve OPENS (no time delay)
 - 3) Downstream Sensor Beam Signal immediately changes HIGH (no time delay), providing a BLOCKED signal to the Upstream Sensor
 - 4) Upstream Sensor valve is CLOSED until its Beam is BLOCKED
 - 5) If both Downstream and Upstream sensors are BLOCKED their valves will be OPEN
 - 6) To release the LAST Downstream sensor, apply a 24VDC signal to the Beam Signal Input wire. (This only releases the last downstream sensor, no other sensors are affected)

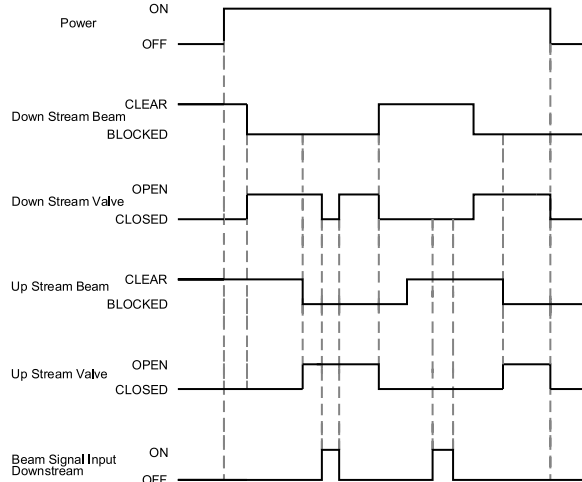

Ordering Information

OSV □ □ - □ 1 1 1 0 □ 1 0

Sensing Type
1 - Retro-reflective
2 - Diffused

Zone Control
0 - Accumulation
1 - Indexing

Valve Option
0 - Without
1 - Normally Open Operation
2 - Normally Closed Operation

Zone Lengths
1 - 2 ft.
2 - 3 ft.
3 - 4 ft.
4 - 5 ft.
Additional zone lengths available

Mating Accessories

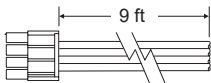

OSV Male Patch Cord
P/N: WOSV10-910

Retro Reflector
P/N: OSVR10-002

Ordering Example: OSV10-11110010

Retro-reflective, accumulation,
2 ft. zone length, without valve

Complete Sample Case

The Canfield Connector Sample Case is a convenient way to acquire a representative sampling from among our full line of products in one efficient package. Use them as product displays. Let your customers touch, feel and examine them up close to see the Canfield Connector difference for themselves. Order the complete set of Connectors, Sensors, Timers and our most recent catalogs and brochures, or request them as individual trays of components.



This all-in-one Complete Case Package is the most comprehensive Sample Case offering.

Order Part Number: CPi10-1-0

What's inside?

Connector Tray – A selection of molded, strain relief and rectified Mini, ISO and Sub-Micro solenoid valve connectors.

Sensor Tray – The current line of cylinder proximity sensors, round connectors and clamps.

Timer Tray – A sampling of commonly ordered sandwich timers, block timers and cord grips.

Literature - A set of the most recent product literature.

Case - A soft-sided, durable carrying case which contains all of the materials.



Custom Assemblies and Molded Connectors

Our Molding Capabilities

At Canfield Connector we specialize in the production of both male and female connectors used in industrial, commercial machinery and mobile applications. From standardized connections such as 8mm four pin round connectors to special connectors used on cell towers, Canfield Connector can make a connector for your demanding application.

Our equipment selection ranges from 35 ton to 200 ton horizontal machines, coupled with vertical machines that perform low pressure molding up to 35 ton styles. Many connectors are overmolded for environmental compliance and are practically indestructible having up to an IP67 rating for dust and water ingress.

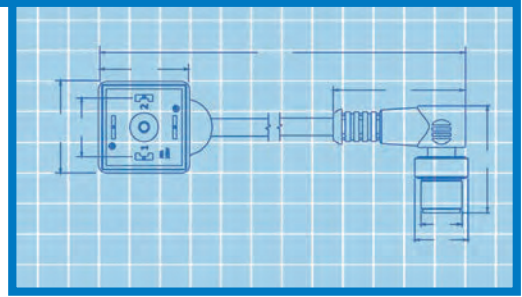

Horizontal Molding



Our horizontal molding machines typically run lights out with automated tools and fixtures that allow us to be cost competitive and quality conscience. With the size ranges we possess, we can offer a large span of part sizes and thicknesses that enable us to process many materials.

Vertical Molding

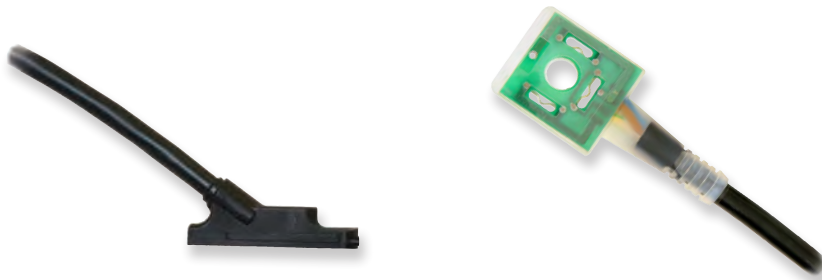

The vertical molding process is used for wired products or in designs that require human oversight. All tools and parts produced are under the guidelines of trained operators and extensive engineering support to guarantee the best output possible and exceed our customer's expectations.



Low Pressure Injection Molding



Canfield Connector also has the capability to offer Low Pressure Injection Molding (LPIM) with contract overmolding of circuit boards and other more fragile parts. This process is newer in the market place and allows us to fill a specific product need to many customers.

Molded Connector Orientation Options					
	Ground Down	Ground Up	Ground Right	Ground Left	Dual Ground
MINI			--	--	--
ISO					
Sub-Micro (8mm & 9.4mm)					

Field Wireable Connector Orientation Options				
	Ground Down	Ground Up	Ground Right	Ground Left
MINI			--	--
ISO				
Sub-Micro (8mm & 9.4mm)				











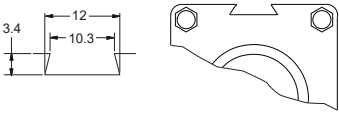

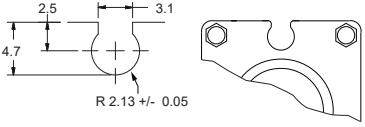

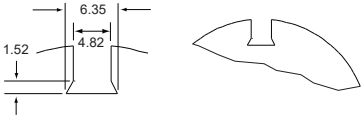

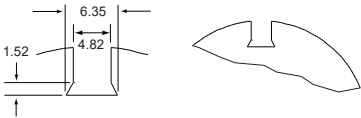

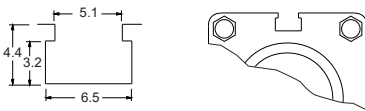
Gasket Detail Options

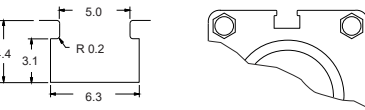
	Profile	Flat
MINI		
ISO		
Sub-Micro 8mm		
Sub-Micro 9.4mm		

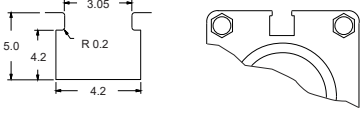
ALL DIMENSIONS ARE IN MILLIMETERS UNLESS OTHERWISE NOTED
GASKET MATERIAL COLORS MAY VARY

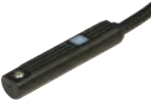
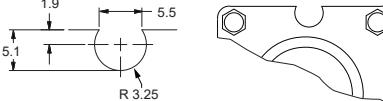
Additional Info

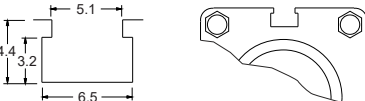
Sensor / Groove Cross Reference Chart

<p>8WS Dovetail</p>			<p>Numatics</p>
<p>9C Round Keyway</p>			<p>DE-STA-CO Robohand SMC Bimba Compact Air Fabco</p>
<p>9D Universal Dovetail</p>			<p>Fabco Numatics Rotomation</p>
<p>9E Universal Dovetail</p>			<p>Fabco Numatics Rotomation</p>
<p>9F 4mm T-Slot</p>			<p>Fabco Festo Numatics Rotomation</p>
<p>9G 6.3mm T-Slot</p>			<p>Fabco Numatics Rotomation</p>
<p>9H 4.2mm T-Slot</p>			<p>4x4 Groove</p>
<p>9K 4.2mm U Groove</p>			<p>Mindman Koganei</p>
<p>9M50 6.5mm D Groove</p>			<p>Norgren</p>
<p>9Q Universal T-Slot</p>			<p>Parker Fabco Festo Numatics Rotomation</p>
<p>9T 7.2mm T-Slot</p>			<p>SMC</p>

Note: All trademarks used in this catalog are the property of their respective owners.

Wire Detail Options

ISO Connector

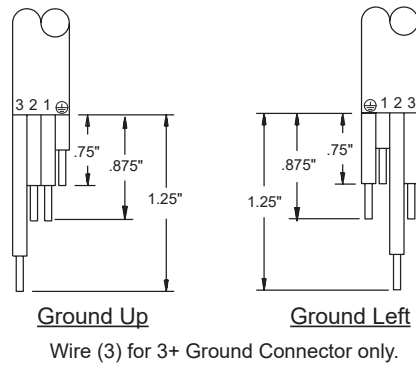
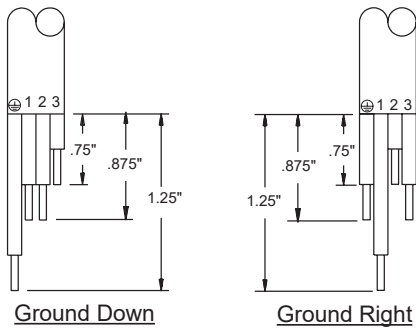

Sub-Micro Connector

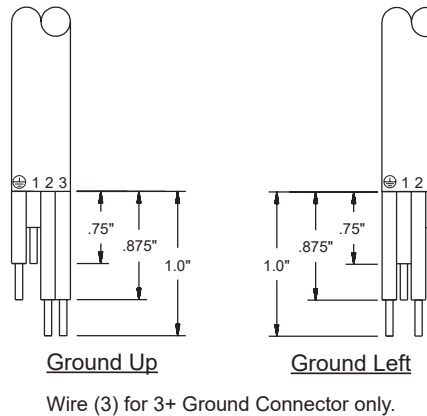
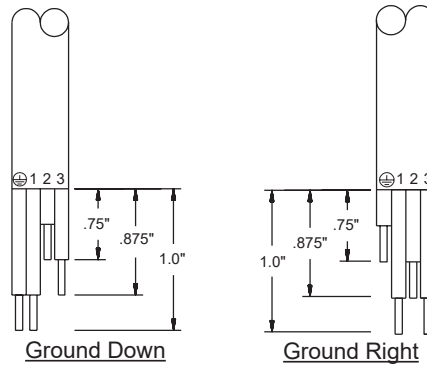

ISO Rectified Connector

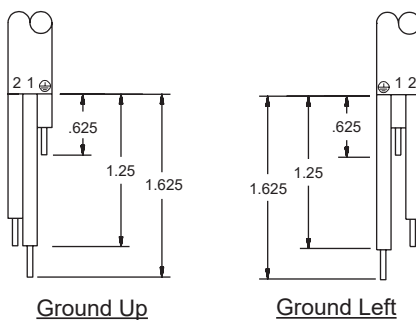
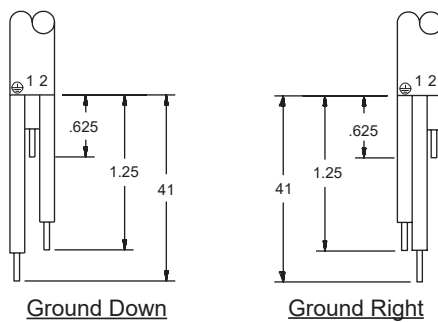

MINI Connector and MINI Rectified Connector

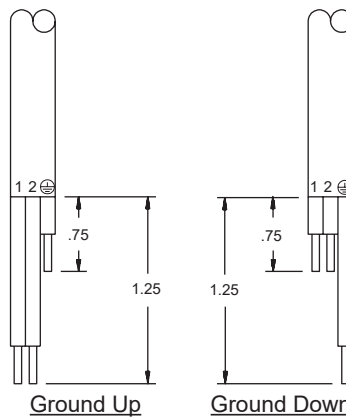

Wire Length

Code	Length in Feet
0	NO WIRE
1	1
2	2
3	3
4	4
5	5
6	6
7	7
8	8
9	9
A	10
B	11
C	12
D	13
E	14
F	15
G	16
H	17
I	18
J	19
K	20
L	25
M	30
N	35
O	N/A
P	40
Q	45
R	50

Additional Info

ALL WIRE ENDS SHOULD BE STRIPPED TO 6.35 MILLIMETERS IN LENGTH

Flat Wire:

SPT - Stranded, Parallel, Thermoplastic

This is always followed by a -1, -2 or -3, signifying insulation thickness for different applications.

HPN - Heater, Parallel, Neoprene

Required for heater-type applications, such as irons, toasters, etc.

Note: We can run some 20 AWG, but mostly we run 18, 16 and 14 AWG, 2 or 3 conductors.
P is always Parallel Wire (Flat).

Jacketed Wire:

S - Stranded (or Service Wire)

J - Junior Service (300 Volt). If no "J" is in the wire type, then it is a hard service (600 Volt).

T - Thermoplastic. If no "T" is in the wire type, then it has a rubber jacket.

O - Oil-Resistant Compound

W - Weather-Resistant Compound

V - Vacuum - as in vacuum cleaner. This is a small O.D. Jacketed wire, very flexible and initially used for vacuum cleaners but now used on many different types of products. Available only in 18 AWG.

Examples:

SV - Stranded Vacuum Rubber Jacketed (NO "T")

SJT - Stranded Junior Thermoplastic

SJTOW - Stranded Junior Thermoplastic, Oil and Weather resistant for UL and CSA.

Inner Conductor Colors

Function	North American (NA)	International (ICC)
Hot	Black	Brown
Neutral	White	Blue
Earth (Ground)	Green	Green w/ Yellow Stripe

Variations of Ohms Law

Volts

$$\text{Volts} = \sqrt{\text{Watts} \times \text{Ohms}}$$

$$\text{Volts} = \frac{\text{Watts}}{\text{Amperes}}$$

$$\text{Volts} = \text{Amperes} \times \text{Ohms}$$

Amperes

$$\text{Amperes} = \sqrt{\frac{\text{Watts}}{\text{Ohms}}}$$

$$\text{Amperes} = \frac{\text{Watts}}{\text{Volts}}$$

$$\text{Amperes} = \frac{\text{Volts}}{\text{Ohms}}$$

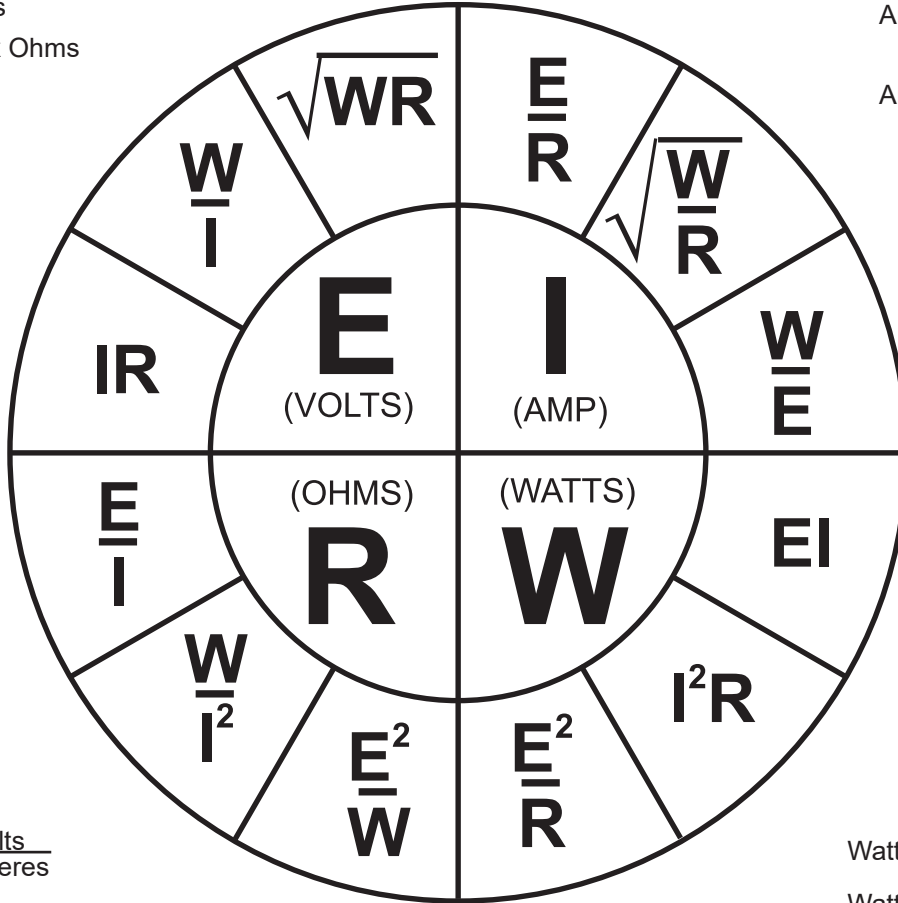

Ohms

$$\text{Ohms} = \frac{\text{Volts}}{\text{Amperes}}$$

$$\text{Ohms} = \frac{\text{Volts}^2}{\text{Watts}}$$

$$\text{Ohms} = \frac{\text{Watts}}{\text{Amperes}^2}$$

Watts

$$\text{Watts} = \frac{\text{Volts}^2}{\text{Ohms}}$$

$$\text{Watts} = \text{Amperes}^2 \times \text{Ohms}$$

$$\text{Watts} = \text{Volts} \times \text{Amperes}$$

Additional Info

INDEX OF PROTECTION (IP) RATINGS (International Electrotechnical Commission Index of Protection)	NEMA STANDARDS (National Electrical Manufacturers Association)
PROTECTION AGAINST SOLID OBJECTS - FIRST DIGIT	ENCLOSURE TYPES FOR NON-HAZARDOUS LOCATIONS
<p> 0 No Protection 1 Protected from solid objects up to 50mm (e.g. accidental touch by hands) 2 Protected from solid objects up to 12mm (e.g. accidental touch fingers) 3 Protected from solid objects larger than 2.5mm (e.g. tools and small wires) 4 Protected from solid objects larger than 1mm (e.g. small wires) 5 Protected from dust; limited entrance (no harmful deposit) 6 Totally protected from dust </p>	<p> Type 1 GENERAL PURPOSE Enclosures are intended for indoor use primarily to provide a degree of protection against contact with the enclosed equipment or locations where unusual service conditions do not exist. Type 2 DRIP TIGHT Enclosures are intended for indoor use primarily to provide a degree of protection against limited amounts of falling water and dirt. Type 3 WEATHERPROOF (Weather Resistant) Enclosures are intended for outdoor use primarily to provide a degree of protection against wind-blown dust, rain and sleet; undamaged by the formation of ice on the enclosure. </p>
PROTECTION AGAINST LIQUIDS - SECOND DIGIT	
<p> 0 No Protection 1 Protected from vertically falling drops of water (e.g. condensation) 2 Protected from direct sprays of water up to 15° from vertical 3 Protected from direct sprays of water up to 60° from vertical 4 Protected from water sprayed from all directions; Limited entrance allowed 5 Protected from low pressure jets of water from all directions; limited entrance allowed 6 Protected from strong jets of water; limited entrance allowed (e.g. for use on ship decks) 7 Protected from the effects of immersion between 15 cm and 1 m for 30 minutes 8 Protected from extended periods of immersion under pressure </p>	<p> Type 3R RAIN TIGHT Enclosures are intended for outdoor use primarily to provide a degree of protection against falling rain and sleet; undamaged by the formation of ice on the enclosure. Type 4 WATERTIGHT Enclosures are intended for indoors and outdoors use primarily to provide a degree of protection against windblown dust and rain, splashing water and hose-directed water; undamaged by the formation of ice on the enclosure. Type 4X WATERTIGHT Enclosures are intended for indoors and outdoors use primarily to provide a degree of protection against corrosion, windblown dust and rain, splashing water and hose-directed water; undamaged by the formation of ice on the enclosure. Type 5 No NEMA equivalent. Type 6 SUBMERSIBLE Enclosures are intended for indoors and outdoors where occasional submersion is encountered. </p>
EXAMPLE - IP67	
<p> 6 Totally protected from dust 7 Protected from the effects of immersion between 15 cm and 1 m for 30 minutes </p>	<p> Type 12 INDUSTRIAL USE Enclosures are intended for indoor and outdoor use primarily to provide a degree of protection against dust falling dirt, and dripping non-corrosive liquids. Type 13 DUSTPROOF Enclosures are intended for indoor and outdoor use primarily to provide a degree of protection against dust spraying of water, oil, and non-corrosive coolant. </p>

Metric to Standard Conversions

Millimeters (mm) x 0.03937	=	inches (") (in)
Centimeters (cm) x 0.3937	=	inches (") (in)
Meters (m) x 39.37	=	inches (") (in)
Meters (m) x 3.281	=	feet (') (ft)
Meters (m) x 1.094	=	yards (yds)
Kilometers (km) x 0.62137	=	miles (mi)
Kilometers (km) x 32.80.87	=	feet (') (ft)
Liters (l) x 0.2642	=	gallons (U.S.) (gals)
Liters (l) x 0.0353	=	cubic feet
Bars x 14.5038	=	pounds per square inch (PSI)
Kilograms (kg) x 2.205	=	pounds (P)
Kilometers (km) x 1093.62	=	yards (yds)
Square centimeters x 0.155	=	square inches
Square meters x 10.76	=	square feet
Square kilometers x 0.386	=	square miles
Cubic centimeters x 0.06102	=	cubic inches
Cubic meters x 35.315	=	cubic feet

Temperature

$$^{\circ}\text{F} = (1.8 \times ^{\circ}\text{C}) + 32$$

$$^{\circ}\text{C} = 0.555 (^{\circ}\text{F} - 32)$$

$$^{\circ}\text{K} = ^{\circ}\text{C} + 273.2$$

Fahrenheit	Celsius	Rankine	Kelvin
602	316.7	1061.7	589.9
572	300.0	1031.7	573.2
542	283.3	1001.7	556.5
512	266.7	971.7	539.9
482	250.0	941.7	523.2
452	233.3	911.7	506.5
422	216.7	881.7	489.9
392	200.0	851.7	473.2
362	183.3	821.7	456.5
332	166.7	791.7	439.9
302	150.0	761.7	423.2
272	133.3	731.7	406.5
342	116.7	701.7	389.9
212	100.0	671.7	373.2
182	83.3	641.7	356.5
152	66.7	611.7	339.9
122	50.0	581.7	323.2
92	33.3	551.7	306.5
62	16.7	521.7	289.9
32	0.0	491.7	273.2
2	-16.7	461.7	256.5
-28	-33.3	431.7	239.9
-58	-50.0	401.7	223.2
-88	-66.7	371.7	206.5
-118	-83.03	341.7	189.9
-148	-100.0	311.7	173.2
-178	-116.7	281.7	156.5
-208	-133.3	251.7	139.9
-238	-150.0	221.7	123.2
-268	-166.7	191.7	106.5
-298	-183.3	161.7	89.9
-328	-200.0	131.7	73.2
-358	-216.7	101.7	56.5
-388	-233.3	71.7	39.9
-418	-250.0	41.7	23.2
-459.7	-273.2	0.0	0.0

AC - Acronym for Alternating Current.

AMP (A) - Abbreviation of Ampere, a unit of measure for electrical current

AWG - American Wire Gauge is a numerical standard used to refer to the diameter Wire Gaugeal area of a wire. Smaller numbers refer to larger Wire Gaugeal areas.

Bridge Rectifier - This is an electrical device made up of four diodes, which perform the function of full wave rectification (converts the full AC sine wave to DC).

Capacitor - This is an electronic device used to store an electric charge or to allow varying current to flow. The ideal capacitor will not allow steady state or DC current to flow. The capacitor is used in many applications including transient suppression, electrical noise filtering, timing circuits, etc.

Conductor - This is a material that can easily conduct (flow) electrical current. Metals are considered to be good conductors of electricity.

Current Surge - This is a short term (transient) condition causing a larger than normal amount of current to flow through a conductor. A current surge can often cause damage to an electrical device that is not properly protected.

DC - Acronym for Direct Current.

DIN - This is an acronym used for the Deutsches Institut fur Normung (German Standardization Institute).

DIN 43650 - A German standard stating the characteristics and requirements of connectors for magnetic valves used in hydraulics and pneumatics.

Diode - This is a solid state electronic component that allows current to flow in only one direction, similar to a check valve used in hydraulic or pneumatic applications. The diode is used in applications including transient suppression, power supply circuits etc.

Electronic Magnetic Sensor - This is a solid state device used to sense a magnetic field. Canfield Connector uses magneto-resistive sensors on all electronic magnetic sensors.

Gauss (Ga) - Unit of measure for magnetic flux density.

Ground - This term is used to define an electrical connection normally common to the chassis of a device or earth ground.

Hertz (Hz) - The unit of measure for frequency in cycles per second.

IP65 - An environmental protection rating of enclosures according to the German Standard DIN 40050.

ISO - This is an acronym used for the International Standards Organization.

LED - An acronym for Light Emitting Diode. A solid state diode which emits light when current passes through it in the proper direction.

MOV - An acronym for Metal Oxide Varistor. A solid state device used to suppress voltage surges/spikes.

NEMA - An acronym for National Electric Manufacturers Association.

Nitrile (Buna) - This is a rubber-like man-made material used extensively in gasket and sealing applications.

Normally Closed - The state of the output or switch is ON with no external influence.

Normally Open - The state of the output or switch is OFF with no external influence.

NPN (Sinking) - Acronym used to describe the polarization of bipolar junction transistors (BJTs). Also associated with a sinking output.

Opto-Coupled - Refers to a technique used to optically activate (turn on) an electronic device, usually a transistor or triac, and physically separate two sides of a circuit. This action is similar to a solenoid relay. The typical opto-coupler incorporates an LED (light emitting diode) as the actuating device.

Parallel Magnet Polarity - The term used to describe the polar orientation of the piston magnet with respect to the cylinder stroke. In this case, the north and south poles are oriented in the same direction parallel to the cylinder stroke.

Perpendicular Magnet Polarity - The term used to describe the polar orientation of the piston magnet with respect to the cylinder stroke. In this case, the north and south poles are oriented perpendicular to the cylinder stroke.

PNP (Sourcing) - Acronym used to describe the polarization of bipolar junction transistors (BJTs). Also associated with a sourcing output.

Rectification - This is a term used to describe an electrical process which converts AC (alternating current) to DC (direct current).

Reed Switch - This is a miniature mechanical switch that changes state when a magnetic field is applied.

Resistor - This is an electronic device that resists the flow of current. Higher resistor Ohm values offer more resistance to the flow of current.

Silicone - This is a rubber-like man-made material used extensively in gasket and sealing applications. It is very resistant to a wide range of chemicals including oils and solvents, and has a very wide temperature range.

Sinking - The term is used here to describe the way a switch is connected in the circuit. If the switch completes the electrical circuit by connecting the load to ground/(-), it is considered to be sinking the load. In a solid state device this is equivalent to a NPN output.

Solid State - This is a term often used to describe an electronic device made up of solid components (no moving parts).

Sourcing - The term is used here to describe the way a switch is connected in the circuit. If the switch completes the electrical circuit by connecting the load to the positive/(+), it is considered to be sourcing the load. In a solid state device this is equivalent to a PNP output.

SPST - Acronym used for **Single Pole Single Throw** switches.

SPDT - Acronym used for **Single Pole Double Throw** switches.

Transistor - This is a solid state device used in electronic circuits. It is often used in switching or amplifier applications.

Triac - This is a solid state device often used to switch AC voltage/current.

Volt (V) - The unit of measure for electrical potential.

Voltage Spike - This is a short term (transient) condition causing a larger than normal amount of voltage to be applied to a circuit. Voltage spikes can often cause damage to an electric device that is not properly protected.

Watt (W) - The unit of measure for electrical power.

We appreciate your business!

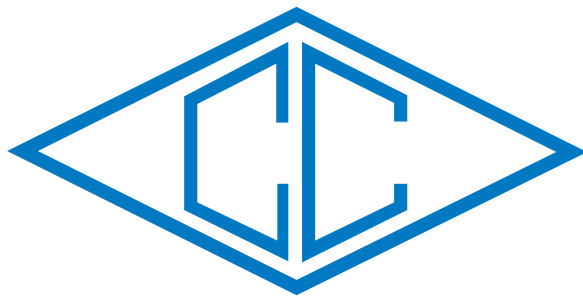

canfield connector

8510 Foxwood Court ♦ Youngstown, OH 44514

1-800-554-5071

Ph:(330)758-8299 ♦ Fx:(330)758-8912

www.canfieldconnector.com

