

MODEL EOS



**End of Stroke Pneumatic and Hydraulic Sensor
 Installation Guide**

Adjustment Procedure

When the unit is connected as shown in figure 1, output [B] will activate when the cylinder is extended and output [A] will activate when the cylinder is retracted. The following procedures assumes the circuit is connected similar to figure 1. If you have not read the "How it Works" section, it is recommended that you do so now. Before proceeding turn both adjustment knobs clockwise 15 turns.

End of stroke sensing:

1. Extended - With normal operating pressure applied actuate the valve to extend the cylinder then adjust the sensitivity for port [B] counter- clockwise until the [B] indicator light turns on. Rotate the adjustment counterclockwise 1/4 additional turn to insure line pressure is above the trip point.
2. Retracted - With normal operating pressure applied actuate the valve to retract the cylinder then adjust the sensitivity for port [A] counter- clockwise until the [A] indicator light turns on. Rotate the adjustment counterclockwise 1/4 additional turn to insure line pressure is above the trip point.
3. Both ports [A] and [B] sensitivity adjustments can be adjusted further counterclockwise to decrease the response time at the end of stroke. The only requirement is that the trip point is set above the pressure differential required to move the piston and below line pressure or 100 psi whichever is less as shown by the gray area in figure 2.

Force/Pressure sensing:

1. Extended - With line pressure set to deliver the desired force, actuate the valve to extend the cylinder then adjust the sensitivity for port [B] counterclockwise until the [B] indicator light turns on.
2. Retracted - With line pressure set to deliver the desired force, actuate the valve to retract the cylinder then adjust the sensitivity for port [A] counterclockwise until the [A] indicator light turns on.
3. Depending on the specific application and the precision of line pressure regulation, the line pressure should be increased 1 PSI or greater above the trip point (not to exceed 200 PSI line pressure). This is to insure line pressure is above the trip point.

Analog Output:

This output can be used to monitor operating pressures for various applications. As pressure differential between ports A and B varies, the analog output voltage varies linearly from approximately 3 to 5 volts with a pressure to voltage response of: .01V/psig.

Example: $A - B = 100 \text{ PSI (Analog}_{\text{out}} = 5 \text{ VDC)}$, $A - B = 0 \text{ PSI (Analog}_{\text{out}} = 4 \text{ VDC)}$, $A - B = -100 \text{ PSI (Analog}_{\text{out}} = 3 \text{ VDC)}$

The above values are approximate and should be used for reference only. This output is only available on DC versions.

Typical Application and Installation

Figure 1

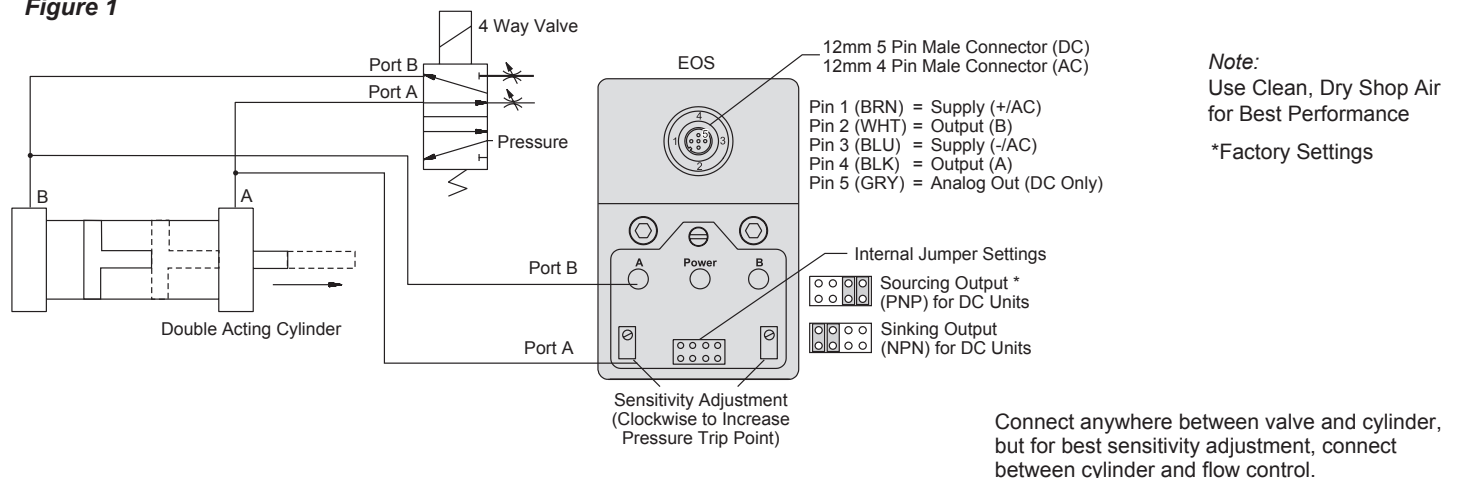

How It Works

(Refer to schematic figure 1 and graph figure 2)

- 1.) Four way valve shifts switching pressure from port "A" to port "B".
- 2.) Pressure builds in line "B" and drops in line "A" until cylinder load / friction are overcome.
- 3.) Dependent upon the response time and valve flow, "B" line pressure exceeds "A" line pressure.
- 4.) Friction / load overcome, cylinder travel begins.
- 5.) End of stroke or clamping force begins, "B" line pressure increases and "A" line pressure decays.
- 6.) When the pressure differential between port "A" and "B" ($B \text{ psi} - A \text{ psi} = \Delta p$) increases to the preset trip point output "B" will activate.

Figure 2

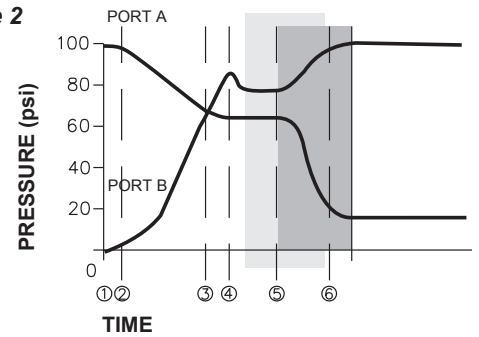

The sensor can be set to trip anywhere in the shaded region depending on desired clamping force and/or delay.

Electrical Hook-up

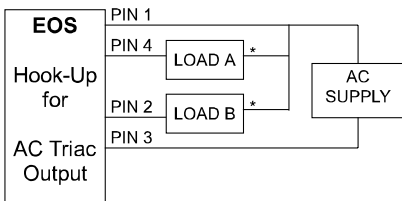
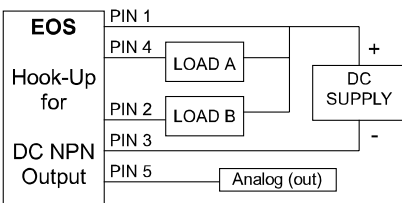
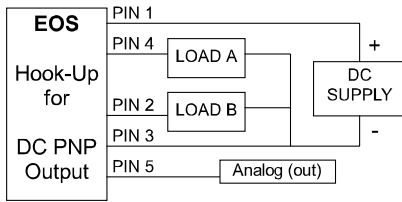

*Use surge suppression on inductive loads (relays, solenoids, etc.).
Call Canfield Connector customer service for recommendations.

Technical Data

- Supply Volt. Range: 12 - 30 VDC
24 - 48, 120 VAC
- Supply Current: 20 mA max.
- Current Output: .5 Amps AC / DC
- Analog Output: 3 -5 VDC (4v @ 0 PSI) 5 mA max.
- Sensing Range: 0 to 100 PSI
- Response Time: 10 ms
- Repeatability: +/- 0.1 PSI
- Hysteresis: 4 PSI max.
- Max. Pressure: 200 PSI
- Adjustability: 0.1 PSI
- Temp. Range: -25° to +85°C
- Enclosure Material: Polyetherimide
- Flame Rating: (UL94) V-O
- Media Compatibility: Liquids and gas compatible with glass, ceramic, silicone, RTV and nickel.

Mounting Template

Dimensions in millimeters unless otherwise noted

For Units w/o Sub-base

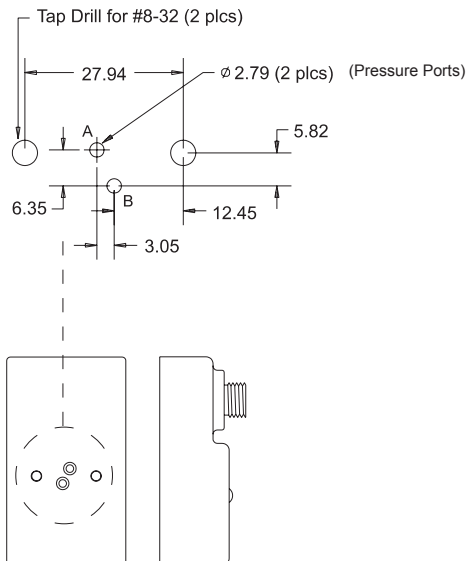

For Units with Sub-base

