

**canfield connector**  
 8510 Foxwood Court  
 Youngstown, Ohio 44514  
 (330) 758-8299 Fax: (330) 758-8912  
 www.canfieldconnector.com

**SERIES MBT  
 MULTIFUNCTION BLOCK TIMER**

**INSTALLATION GUIDE  
 For: MBT-100000**

ALL DIMENSIONS ARE MILLIMETERS UNLESS OTHERWISE NOTED

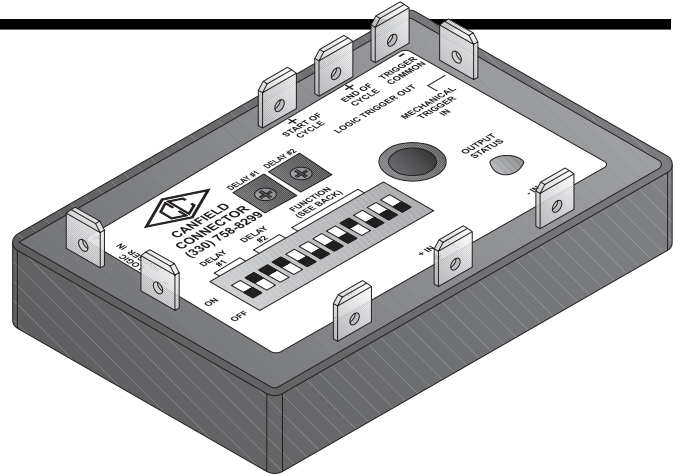
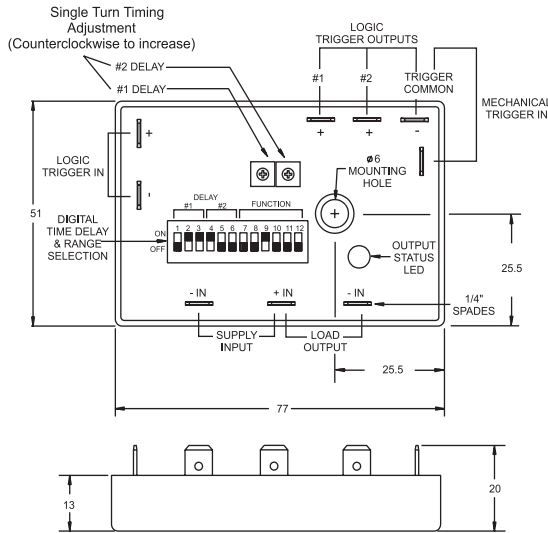

**Warning:**  
 Do not exceed the electrical rating of this device or permanent damage can result.

**Hook-Up**

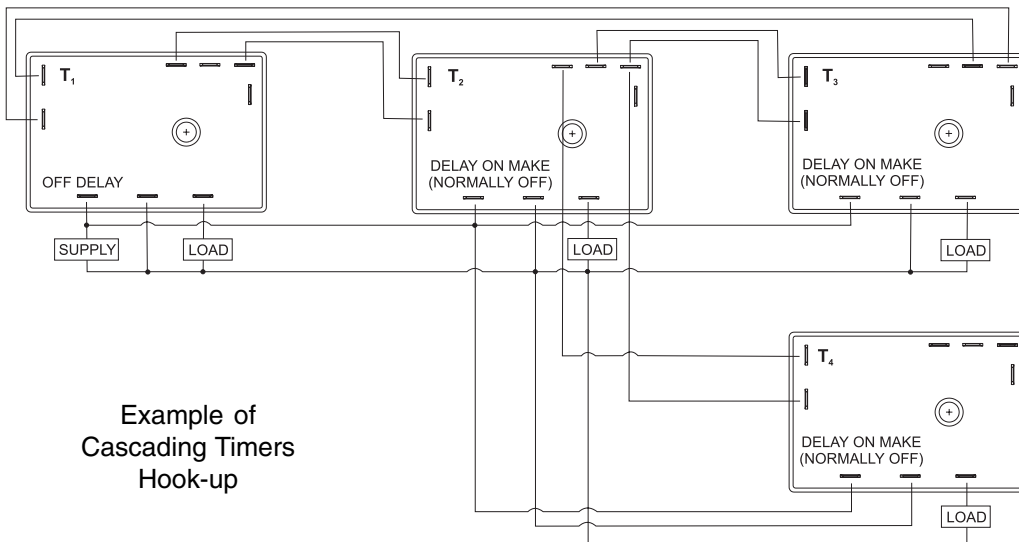

Example of Cascading Timers Hook-up

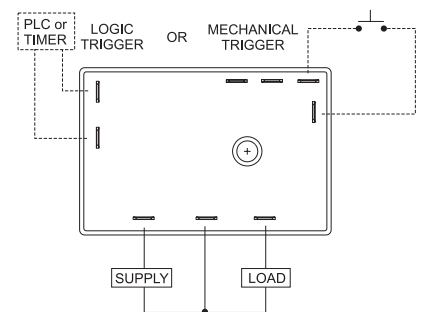

Single Timer Hook-up

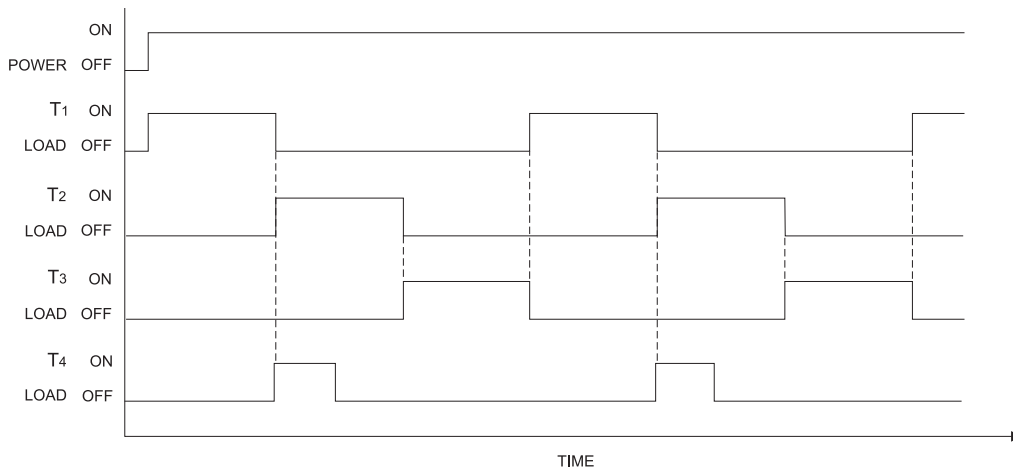

## Operating Parameters

Maximum timer current draw:	2 mA (No Load)
Absolute maximum input voltage:	240V AC/DC
Input voltage range:	24-240 VAC (50/60Hz) 12-240 VDC
Maximum output current:	1 Amp
Logic trigger in:	5-48 VDC (10k input impedance)
Logic trigger out:	5.5 V @ .55 mA max.
Mechanical trigger in:	80 mA max. current draw

Ambient temperature range:	-20 to 60 °C
Max. reset time:	50 ms
Repeat accuracy:	0.1% or 10 ms whichever is greater
Time delay variable over ambient temperature range:	+/- 2%
Enclosure material:	ABS
Potting:	Epoxy

## Timer Programming

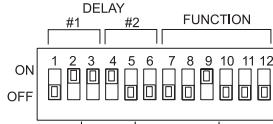

### Switch Symbols

ON = ON

OFF = OFF

Chart 1

#1 Delay Range (seconds) All Functions	Switch Settings
0.10 - 4.70	ON OFF
0.36 - 18.0	ON OFF
2.80 - 150	ON OFF
23.0 - 1200	ON OFF
Delay = above range X 1	ON OFF
Delay = above range X 100	ON OFF

Chart 2

#2 Delay Range (seconds) Cycle Function Only	Switch Settings
0.10 - 4.70	ON OFF
0.36 - 18.0	ON OFF
2.80 - 150	ON OFF
23.0 - 1200	ON OFF
Delay = above range X 1	ON OFF
Delay = above range X 100	ON OFF

Chart 3

Function	Switch Settings
#1 Off Delay (Retriggerable)	ON OFF
#2 On Delay (Retriggerable)	ON OFF
#3a Cycle (On First)	ON OFF
#3b Cycle (Off First)	ON OFF
#4a Square Wave (On First)	ON OFF
#4b Square Wave (Off First)	ON OFF
#5 Delay on Break (Normally Off)	ON OFF
#6 Delay on Break (Normally On)	ON OFF
#7 Delay on Make (Normally Off)	ON OFF
#8 Delay on Make (Normally On)	ON OFF
#9a Toggle (On First)	ON OFF
#9b Toggle (Off First)	ON OFF

## Operation

**General Description** - The MBT is a Solid State Timer/Toggle Latch, programmable in 12 modes of operation (refer to chart 3). It can operated individually or cascaded to perform virtually any timing sequence desired.

**Mechanical Trigger Input** - A switch closure at this input begins or resets the timing period of any non-cycling MBT function. Refer to page 3 - 4 for timing diagrams.

**Logic Trigger Input** - A sourcing or sinking voltage signal (5 - 48 volts) at this input begins or resets the timing period of any non-cycling MBT function. Refer to pages 3 - 4 for timing diagrams.

**Logic Trigger Outputs** - The logic output produces a voltage signal in sync with the timing cycle (see timing diagrams). Timers can be cascaded when the logic output of one timer is connected to the logic input of other timers. The #1 logic output produces a voltage level opposite the #2 logic output.

**Cascading Multiple Timers** - There is no limit to the number of MBTs that can be cascaded in series (the logic output of one MBT connected to the logic input of one other MBT). However the number of parallel MBTs (the same logic output connected to the logic input of more than one other MBT) should be limited to 10 MBTs.

**Function #1 Off Delay (Retriggerable)**

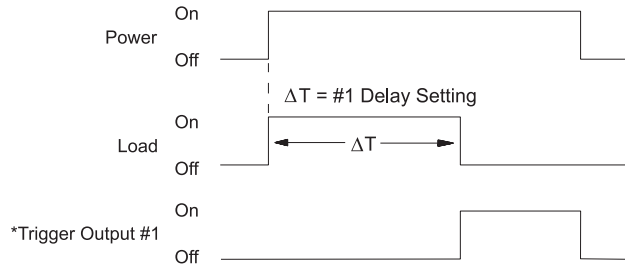

Load is energized for  $\Delta T$  upon application of power. Reset occurs when power is removed.

Refer to charts 1 and 3 on previous page for switch settings.

\*Trigger Output #2 level is always opposite of Trigger Output #1.

**Function #2 On Delay (Retriggerable)**

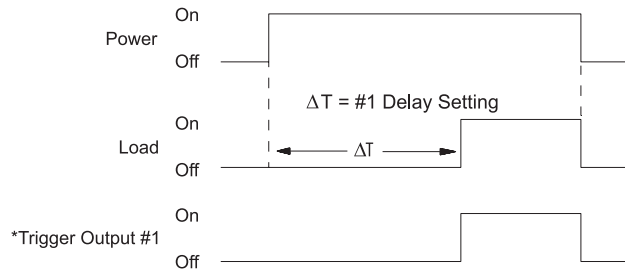

Load remains Off for  $\Delta T$  upon application of power. Reset occurs when power is removed.

Refer to charts 1 and 3 on previous page for switch settings.

\*Trigger Output #2 level is always opposite of Trigger Output #1.

**Function #3a / 3b Cycle**

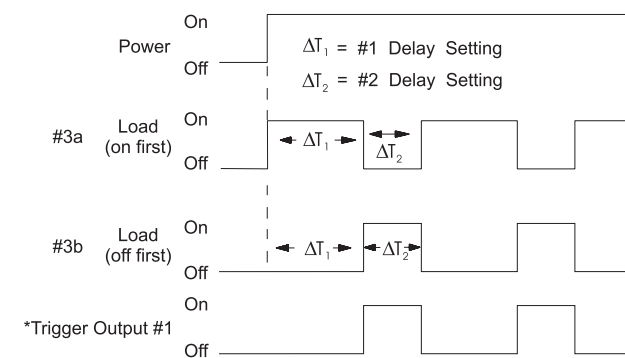

Load cycles  $\Delta T_1$  and  $\Delta T_2$  when power is applied. Reset occurs when power is removed.

Refer to charts 1, 2 and 3 on previous page for switch settings.

\*Trigger Output #2 level is always opposite of Trigger Output #1.

**Function #4a / 4b Square Wave**

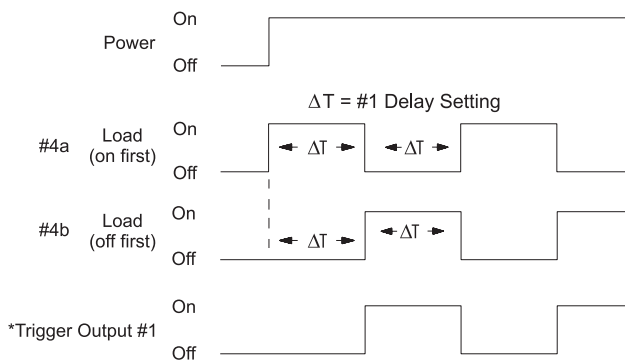

Load cycles with equal On and Off times when power is applied. Reset occurs when power is removed.

Refer to charts 1 and 3 on previous page for switch settings.

\*Trigger Output #2 level is always opposite of Trigger Output #1.

**Function #5 Delay On Break (Normally Off)**

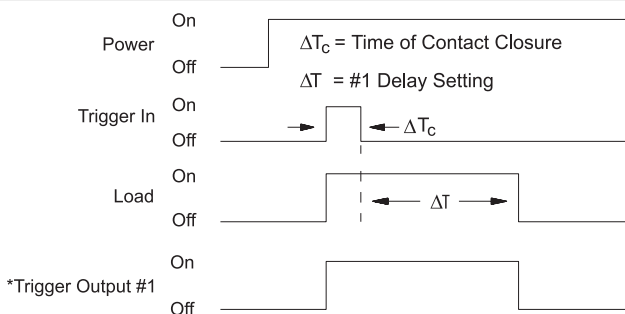

When power is applied, load remains Off. Load is energized for  $\Delta T_c + \Delta T$  when trigger switch is closed and opened. Reset occurs when load is Off and trigger is re-applied.

Refer to charts 1 and 3 on previous page for switch settings.

\*Trigger Output #2 level is always opposite of Trigger Output #1.

**Function #6 Delay On Break (Normally On)**

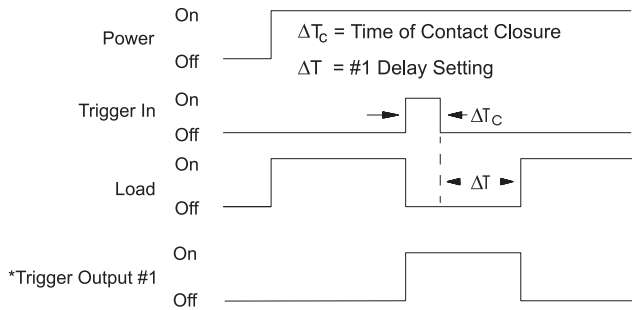

When power is applied, load is energized and remains energized until the trigger switch is closed. Load is then Off for  $\Delta T_C + \Delta T$ . Reset occurs when load is On and the trigger is re-applied.

Refer to charts 1 and 3 on previous page for switch settings.

\*Trigger Output #2 level is always opposite of Trigger Output #1.

**Function #7 Delay On Make (Normally Off)**

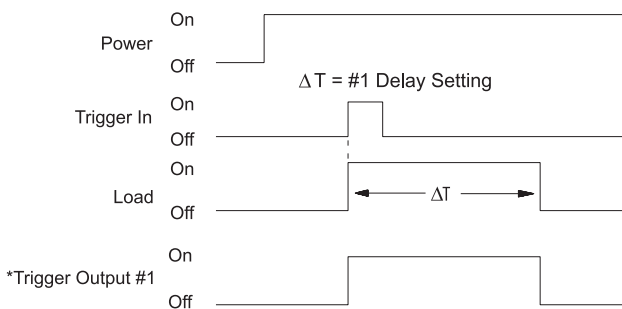

When power is applied, load remains Off. Load is energized for  $\Delta T$  only upon closure of a normally open momentary contact switch (trigger). Reset occurs when load is Off and the trigger switch is closed.

Refer to charts 1 and 3 on previous page for switch settings.

\*Trigger Output #2 level is always opposite of Trigger Output #1.

**Function #8 Delay On Make (Normally On)**

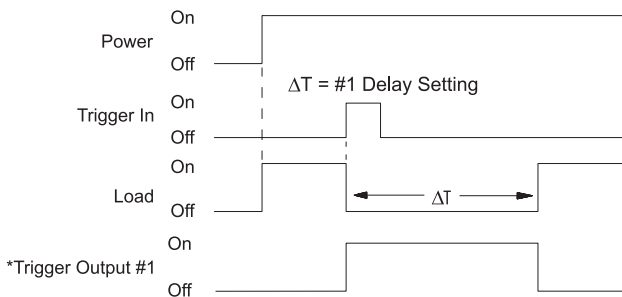

When power is applied, load is energized. Load de-energizes for  $\Delta T$  only upon closure of a normally open momentary contact switch (trigger). Reset occurs when load is On and the trigger switch is closed.

Refer to charts 1 and 3 on previous page for switch settings.

\*Trigger Output #2 level is always opposite of Trigger Output #1.

**Function #9a / 9b Toggle**

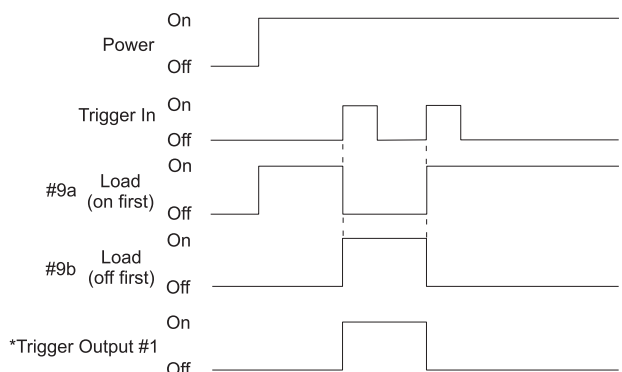

When power is applied, load is On. Load switches state (On/Off) with each application of trigger

Refer to chart 3 on previous page for switch settings.

\*Trigger Output #2 level is always opposite of Trigger Output #1.